

MINI CUP HOLDERS WITH IN-BUILT SPRING

For a further bulk and weight reduction, as well as to meet the requirements of discharge machines for plastic moulding presses manufacturers, these cup holders are made with an in-built spring and an anodised aluminium cup fixing stem. Also these cup holders allow the installation of cups with male threaded support only. The particular shape of the brass drive bush for fastening the cup holder to the machine prevents any rotation of the stem and, therefore, of the cup. The vacuum connection is radial.

2



VERSION 20 80 . .

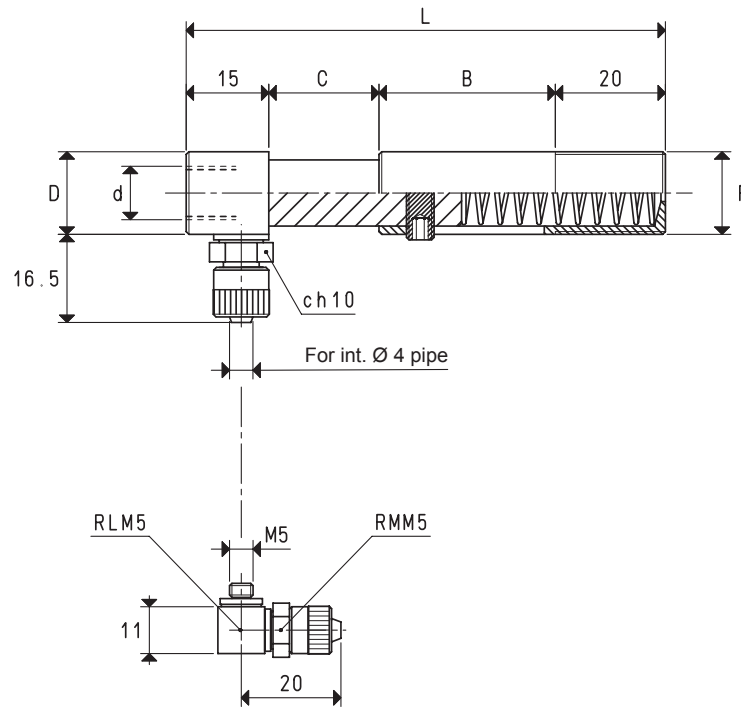

VERSION 20 80 . . L

CUP HOLDERS WITH STRAIGHT QUICK COUPLER FOR PLASTIC HOSE Ø 4 X 6

Art.	B	C stroke	d Ø	D Ø	F Ø	L	Weight g
20 80 15	22	15	G1/8"	15	M10 x 0.75	72	26
20 80 20	32	20	G1/8"	15	M15 x 1.00	87	42

Note: Add the letters FC to the code to order chromed iron cup holders.

Note: Add the letter L to the code to order cup holders with L-type fittings.

Conversion ratio: inch = $\frac{mm}{25.4}$; pounds = $\frac{g}{453.6}$ = $\frac{Kg}{0.4536}$

3D drawings available at www.vuototecnica.net

2.17