

## VACUUM CUP WITH ONE BELLOW AND WITH VULCANISED SUPPORT

1



The cups described in this page, unlike the previous ones, are vulcanised onto an aluminium hexagonal support with a male or female threaded connector, inside of which there is an M8 threaded hole for the possible insertion of a calibrated grub screw (see page 1.118).

The main feature of these BELLOW CUPS is that they quickly crumple up during the grip, thus lifting the load for a few centimetres, independently of the movements of the lifting frame; this quick movement avoids that the load beneath, remains stuck to the lifted one. Due to this feature they are particularly suited for handling thin metal sheets, glass sheets, chipboard or compressed wood panels, laminated plastic etc. Due to their high flexibility they can also be used to compensate flatness errors or for the grip of inclined surfaces.

These cups are available in the standard compounds and can be supplied in special compounds listed at page 21 in minimum amounts to be defined in the order.

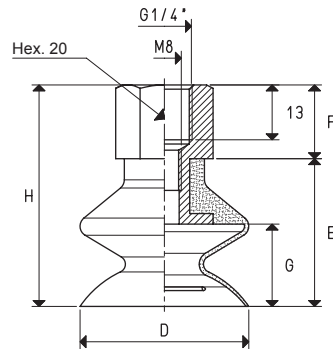

CUPS WITH ONE BELLOW WITH FEMALE VULCANISED SUPPORT

Art.	Force Kg	D Ø	E	F	G	H	Support material	Weight g
08 40 30 *	3.14	40	35	17	18	52	aluminium	32.4
08 50 30 *	4.90	50	37	17	20	54	aluminium	40.9
08 60 30 *	7.06	60	39	17	21	56	aluminium	53.6
08 85 30 *	14.08	85	50	17	31	67	aluminium	122.0

\* Complete the code indicating the compound: A= oil-resistant rubber; N= natural para rubber; S= silicon

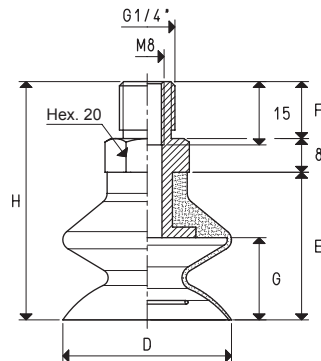

CUPS WITH ONE BELLOW WITH MALE VULCANISED SUPPORT

Art.	Force Kg	D Ø	E	F	G	H	Support material	Weight g
08 40 30 M *	3.14	40	35	13.5	18	56.5	aluminium	29.1
08 50 30 M *	4.90	50	37	13.5	20	58.5	aluminium	39.0
08 60 30 M *	7.06	60	39	13.5	21	60.5	aluminium	51.2
08 85 30 M *	14.08	85	50	13.5	31	71.5	aluminium	115.0

\* Complete the code indicating the compound: A= oil-resistant rubber; N= natural para rubber; S= silicon

Conversion ratio: inch =  $\frac{mm}{25.4}$ ; pounds =  $\frac{g}{453.6}$  =  $\frac{Kg}{0.4536}$

GAS - NPT thread adapters available at page 1.117