

VACUUM MANAGERS

OUR PROMISE

Our promise is to help our clients improve their productivity through a better understanding of vacuum automation, at each step of their manufacturing processes.

For this, Coval develops high quality innovative products and engages itself in offering its clients with quality consulting, reliable solutions and services adapted to their needs.

And this is why it says, "VACUUM MANAGERS" under **COVAL**.

We impose ourselves with strict exigencies during the conception and manufacturing of our products, thereby giving a special attention to the factors related to efficiency and the reliability of your installations (reduction of the energy consumption, noise level, clogging and over all cost of the equipment).

Our ambitious strategy relies on three fundamentals:

- A know-how of more than 20 years in the vacuum automation field.
- A cooperative strategy with our experienced staff & innovation partners.
- A strong presence in the proximity of our clients thanks to our sales team, our subsidiaries and our authorized distributors & independent representatives.

Michel Cecchin, C.E.O.

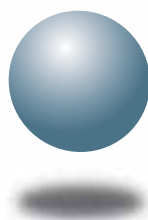

COVAL
vacuum managers

COVAL SERVICES

► 3D ONLINE LIBRARY

You have free access to 3D files of all our products in formats compatible with the main CAD software from our web site at www.coval.com

You can use this fast, new, reliable service to make it easier to integrate our components directly into your designs.



► ALL THE COVAL PRODUCT RANGES ON LINE

Just click to access our entire product range, which is regularly updated, and download all our catalogues.

www.coval.com

► TELEPHONE HOTLINE

Your questions cover a wide range of subjects: technical enquiries, enquiries for products or spare parts, usage advice, requests for technical documentation or more specifically elimination of pressure loss, noise reduction, and energy savings.

Our advisers are specialists in vacuum automation applications and can provide you with technical solutions to get the best performance from your production equipment.

Please do not hesitate to contact your local COVAL adviser.

► SPECIFIC SOLUTIONS

Your business sometimes presents situations for which standard components are not suitable.

COVAL can provide you with solutions based on your specifications using the full range of technologies in which our engineers are specialized:

- **adaptation of a product to your specifications.**

ADVANCED VACUUM SOLUTIONS

Summary

Introduction: guide to vacuum handling

p. vii to p. xii







SUCTION PADS

Chapter 1 General points about suction pads

p. 1/1 to 1/6















Chapter 2 Standard suction pads

pages 2/2 to 2/23

	VP series flat suction pads	2/2 and 2/3		C series high-performance suction pads	2/11 to 2/13
	VPG series extra-flat suction pads	2/4 and 2/5		VSBM series foam rings	2/14
	VSA series suction pads with 1.5 bellows	2/6 and 2/7		Assembly diagrams	2/15 to 2/21
	VS series suction pads with 2.5 bellows	2/8 and 2/9		Male and female fittings	2/22 and 2/23
	VPO series oblong suction pads	2/10			

Chapter 3 Special purpose suction pads





pages 3/2 to 3/18

	MVS series bag-opening suction pads	3/2		VPV, VSAV, VSV, VSAOV series anti-abrasion suction pads	3/10 and 3/11
	VSO series egg-handling suction pads	3/3		VPS series VPS suction pads	3/12
	VSD, VSE, VSP series cake-handling suction pads	3/4		VCD, VPCD series CD-handling suction pads	3/13
	VSB, VSD series long stroke suction pads	3/5		VPYR series radial ball-joint suction pads	3/14
	VSBO series bottle-handling suction pads	3/6 and 3/7		SPL series "heavy load" suction pads	3/15
	VPA series paper-handling suction pads	3/8		Steel series bonded seal steel suction pads	3/16
	VPR series suction pads for mailing applications	3/9		VA series seal removable steel suction pads	3/17
	VPAG series rounded suction pads	3/9			

Summary

SUCTION PADS (cont.)

Chapter 4 Generic suction pads pages 4/2 to 4/9

	VPU series flat suction pads	4/2 and 4/3		VSAJ series suction pads with 1.5 bellows	4/8
	VSAB series suction pads with 1.5 bellows	4/4 and 4/5		VSG series suction pads with 2.5 bellows	4/9
	VSAG series suction pads with 1.5 bellows	4/6 and 4/7			

Chapter 5 Suction pad accessories pages 5/2 to 5/14

	TS, YS series spring systems	5/2 and 5/3		PBA series automatic shut-off valves	5/10
	RSC series systems with 4 compensated springs	5/4		PBP series sensor valves for porous products	5/11
	TSOP - TSO series anti-rotation spring systems	5/5		PBE series sensor valves for air-tight products	5/11
	L series extensions	5/6		IMUKGL, IMU series axial ball-joints	5/12
	Miscellaneous gripping	5/7		CSP series piloted safety valves	5/13
	Suction pad nozzle fittings groups 1 and 2	5/8		BM series foam strips	5/14
	PMG2 series mechanical feelers	5/9			







Summary

VACUUM PUMPS









Chapter 6 Vacuum pumps pages 6/2 to 6/10

General points	6/2	Coval vacuum pump range	6/6 to 6/8
Choosing a vacuum pump	6/3	Evacuation time	6/9 and 6/10
Comparison	6/4 and 6/5	Vacuum pump weight	6/10

Chapter 7 Micro/mini-ejectors pages 7/2 to 7/15

 CIL series in-line ejectors	7/2 and 7/3	 VR 10, 12, 14 series heavy duty in-line ejectors	7/10 and 7/11
 GVA series in-line ejectors	7/4 to 7/7	 GVR 09 S, 10, 12, 14 series micro-ejectors	7/12 and 7/13
 VR 05, 07, 09 series heavy duty in-line ejectors	7/8 and 7/9	 GV series standard ejectors	7/14 and 7/15





Chapter 8 Modular vacuum pumps pages 8/1 to 8/20

The range of Coval modular vacuum pumps	8/1	 GVS series - safety vacuum pump with electric vacuum control and blow-off	8/12 and 8/13
 GVP series modular vacuum pumps	8/2 and 8/3	 GVS series - safety vacuum pump with pneumatic vacuum control and blow-off	8/14 and 8/15
 GVC series automatic blow-off capacity vacuum pump	8/4 and 8/5	Modular vacuum pump options	8/16 to 8/18
 GVCS series - vacuum pumps with electric vacuum control and automatic blow-off	8/6 and 8/7	Performance curves for modular vacuum pumps	8/19
 GVPS series vacuum pump with electric vacuum control	8/8 and 8/9	 CD, CC series connectors for vacuum switches	8/20
 GVPD series vacuum pump with electric vacuum control and blow-off	8/10 and 8/11		

Summary

VACUUM PUMPS (cont.)

Chapter 9 Intelligent vacuum pumps pages 9/2 to 9/18

	GEM series integrated energy-saving vacuum pumps	9/2 to 9/4		GVMAX series - self-regulating vacuum pumps (pneumatic vacuum control and blow-off)	9/11
	GEMP series simple energy-saving vacuum pumps	9/5 and 9/6		GVMAX V2 series - special self-regulating vacuum pumps (electric vacuum control and blow-off)	9/12 and 9/13
	Air-saving vacuum pumps general points - applications	9/7 to 9/9		GVMAX V3 series - self-regulating vacuum pumps (electric vacuum control and blow-off)	9/14 and 9/15
	GVMAX series - self-regulating vacuum pumps (electric vacuum control and blow-off)	9/10		GVE series - self-regulating vacuum pumps with pneumatic vacuum control	9/16 and 9/17

Chapter 10 High flow vacuum generator pages 10/2 to 10/6

	M--C series - air amplifiers	10/2 to 10/6
---	------------------------------	--------------

Chapter 11 Vacuum pump accessories pages 11/2 to 11/8

	SIL GV, SIL K--C series diffuser-type silencers, through-type silencers	11/2		FVUM, FVUG series in-line filters	11/6
	MS series blow-off device	11/3		FVG series mini-vacuum filters	11/7
	FVI series vacuum filters	11/4 and 11/5		Pneumatic controls for vacuum pumps	11/8

Chapter 12 Vacuum switch range pages 12/1 to 12/6

	PSA 100 C series electronic vacuum switch with digital display	12/1		PSE 100 P series pneumatic vacuum switch	12/4
	PSP 100 series electronic vacuum switch	12/2		PSE 100 PK series pneumatic vacuum switch	12/5
	PSE 100 E series electric vacuum switch	12/3		VAF 111 series vacuum gauge	12/6

Summary

ACCESSORIES

Chapter 13 Peripheral devices pages 13/2 to 13/10

 NVS, NVR, NVA series
vacuum feeders 13/2

 RDV, RCOV, Y series
screwed vacuum fittings with
O-ring 13/3

 RD, RC, RT, RU series
standard screwed vacuum fittings 13/4

 RVM, RVF, RVT - TVR - COV series
fittings, vacuum tubes, clamps 13/5

 REV 38 series
vacuum regulator 13/6

 AG series
3-channel vacuum valves 13/7

 PA series
angular grippers 13/8

 AP2, AP3 series
solenoid valve modules 13/9

Vacuum handling guide

Vacuum applications and measurements	p. viii
Suction pad operating mode	p. ix
Vacuum generation techniques	p. x et p. xi
The process of defining an installation	p. xii

Vacuum applications and measurements

■ Vacuum handling development

An industrial vacuum applied to suction pads is an efficient method for handling objects and materials.

This technique was developed to answer the automation needs in the industry with applications in parts assembly, finishing, testing, transfer, packaging, etc.

It is designed particularly for the automobile, wood and plastics industries, as well as all object transformation activities: food, electricals, furniture, etc.

Vacuum handling has become a key production technology, and this document will detail the rules, procedures and components involved.

■ Measuring the vacuum level

Scientists use absolute pressure, with a scale that starts at the perfect vacuum, with atmospheric pressure measuring roughly 1 bar.

For industrial applications, relative pressure is preferred. This makes a clear distinction between vacuum (negative pressure) and positive pressures.

In handling applications, the vacuum is only effective through its difference compared with atmospheric pressure. However, atmospheric pressure varies slightly depending on the altitude of the application site. This is why it is more practical to express the vacuum level as a percentage of the atmospheric pressure.

The scale shown to the right expresses the correspondence between pressures expressed in bar and mbar and the vacuum level expressed as a percentage of the atmospheric pressure. This correspondence is accurate for use at an altitude of 100m. This is the measurement that we will use when discussing suction pads, since this is the most common altitude of industrial sites.

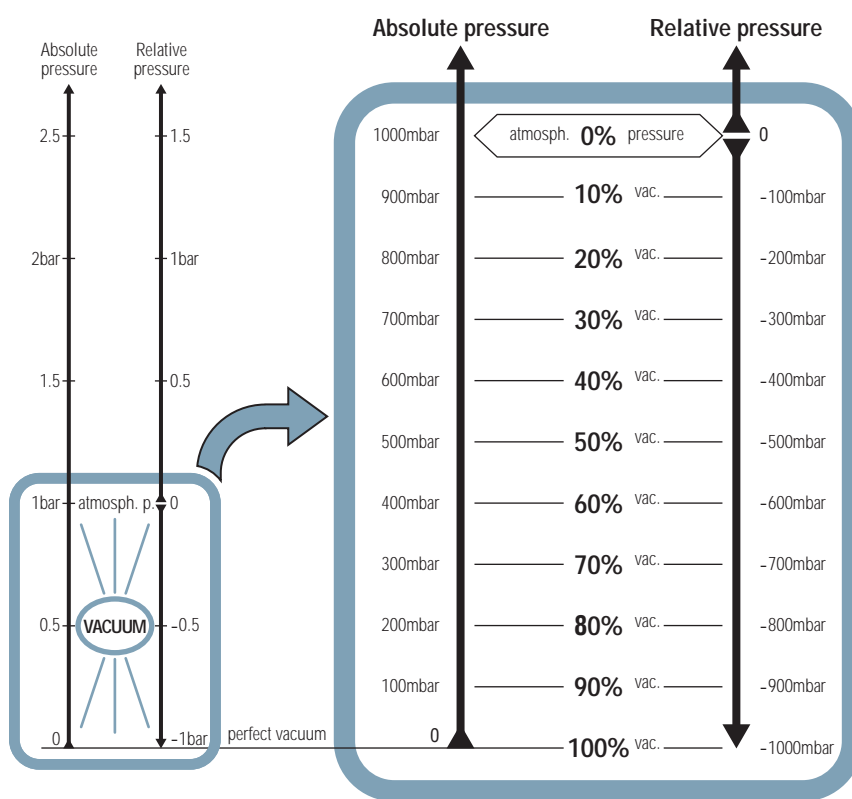

■ Recommended vacuum levels

The handling system provides a level of effort that is proportional to the level of the vacuum that generates it (see curves opposite). For the most efficient operation, a maximum vacuum level is recommended. However, the curves also show that a high level of vacuum:

- has a high energy cost
- takes a long time to establish

This is why the vacuum levels used should be limited, from 30% when a high flow of vacuum needs to be maintained, to 80% in an air-tight circuit (no flow required to maintain the vacuum).

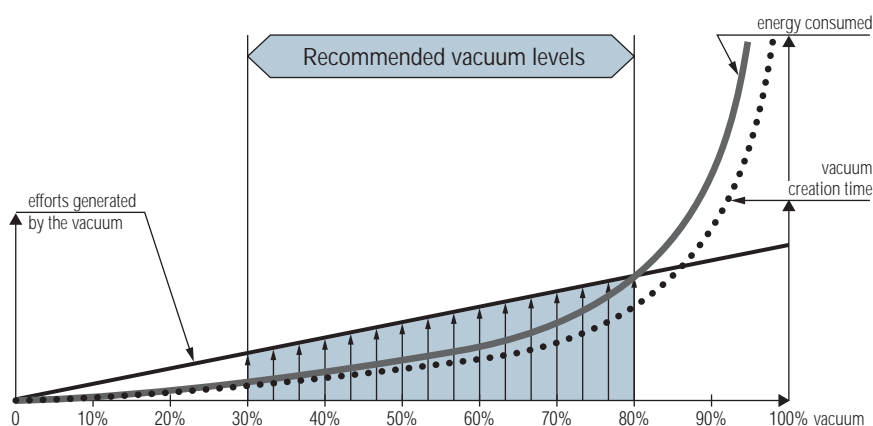

Suction pad operating mode

■ Vacuum handling phases

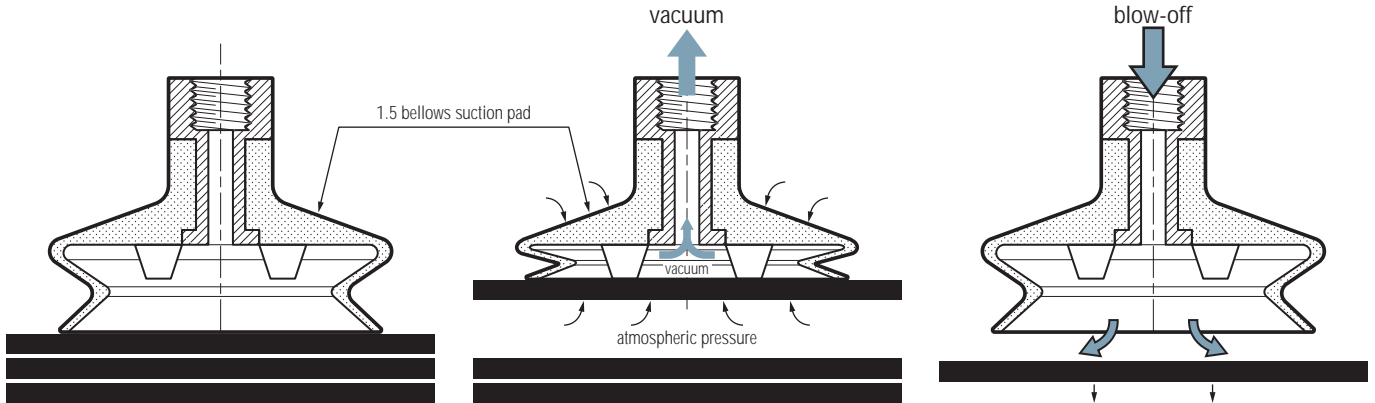

1- Approach

For a shock-free contact with the surface to be gripped, and to configure to its shape, the suction pad in this instance has 1.5 bellows. Chapter 2 outlines a choice of suction pads and fixings to ease this phase.

2- Gripping

Vacuum is then applied to the suction pad, which lifts the object pushed by atmospheric pressure.

The suction pad and the object then remain bonded together throughout the entire process (transfer, packaging, etc).

3- Release

At the end of the suction process, the vacuum is interrupted to release the object.

Most often, an air blow-off will help this process and avoid sticking. This also helps to quicken the move to the next cycle.

■ Vacuum levels and suction pad sizing

In practice, the majority of surfaces requiring suction are not air-tight. If the material is porous or the surface is rough, it is inevitable that air will escape into the vacuum through the material or under the edges of the suction pad. In this situation, a high flow of vacuum must be maintained to compensate for air leaks and to maintain gripping. This can be done economically and efficiently at a low level of vacuum.

Within the recommended vacuum range of 30% to 80%, two distinct zones must be distinguished, depending on the nature of the object to be gripped.

1 - Porous materials

The 30 to 55% vacuum zone is both economical and efficient, given the amount of vacuum flow required. The suction pads should be of the appropriate size to obtain the required gripping efforts.

2 - Air-tight surfaces

In this case, the 55 to 80% zone gives excellent results. The resulting effort is higher (curves opposite), so that more compact suction pads may be used.

Chapter 2 outlines a method for sizing the suction pads, in relation to the chosen vacuum level.

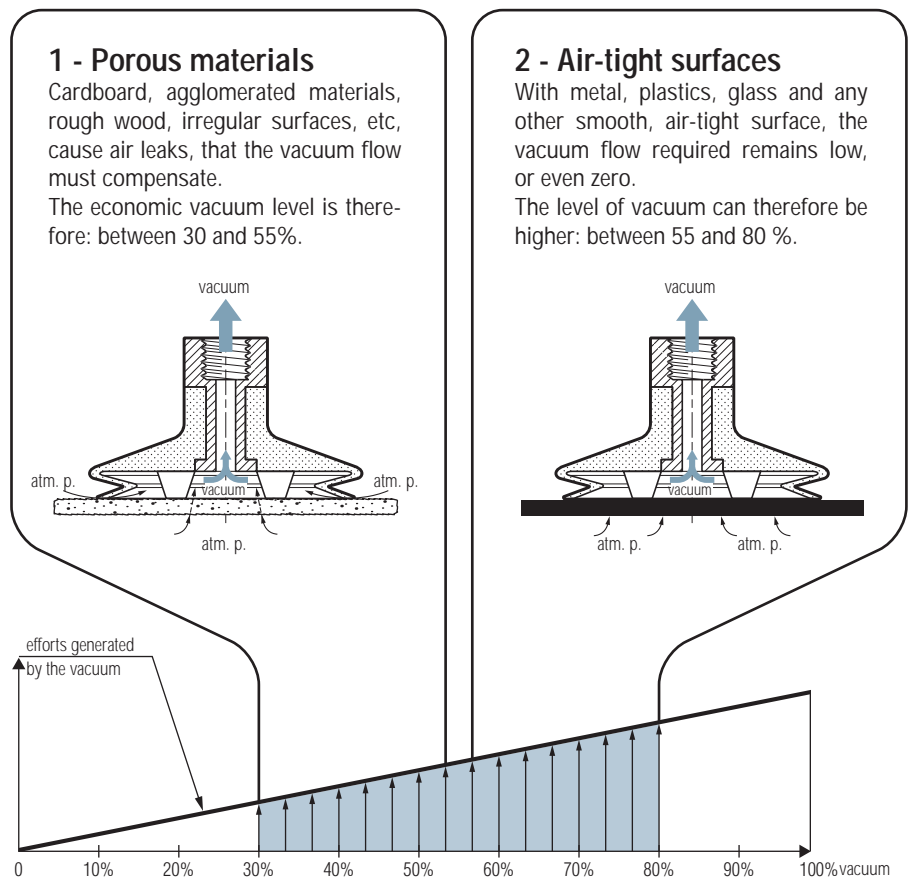

Vacuum generation techniques

1- Continuous vacuum, using rotary vacuum pumps

Rotary vacuum pump principle

The most commonly used type of rotary pump is the sliding vane pump (illustration).

The blades are drawn at high speed by the rotor. Thus, the centrifugal force pushes them against the pump casing. The air is displaced and pushed out, creating a vacuum at the inlet.

For low-level vacuums, turbines are also used, which operate in a similar manner to vacuum cleaners: a rotor with blades that do not make contact with the casing, causing air to move at high speed.

Range of rotary vacuum pumps

To maintain optimum output, rotary pumps must remain within average power levels: from 1 to 10 Kw. The suction ability generated is much higher than the normal requirements of industrial suction pads.

Usage applications and practice

Rotary pumps are used where a constant, high level of suction flow is required. Machines packaging objects under vacuum are a typical example of this.

However, in the area of vacuum gripping, rotary pumps are only used in rare instances, where an object requires a high level of suction flow that needs to be maintained throughout the cycle.

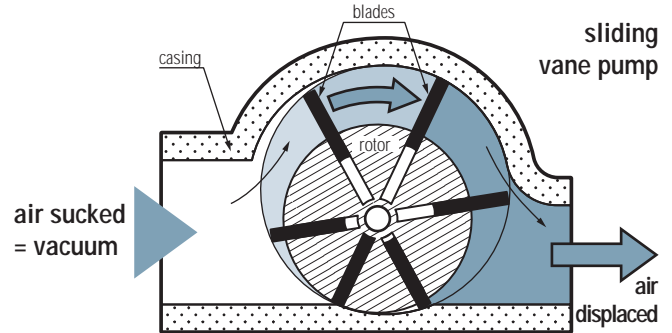

Rotary vacuum pumps	
<ul style="list-style-type: none"> • Constant consumption, continuous generation of vacuum, even for intermittent requirements: not suitable for intermittent vacuum generation requirements. • Located far from the suction pads. 	<p>Applications :</p> <ul style="list-style-type: none"> • Vacuum sources for various processes such as vacuum packing, etc. • Holding of objects maintained throughout the cycle with large suction flow (porous objects etc.)

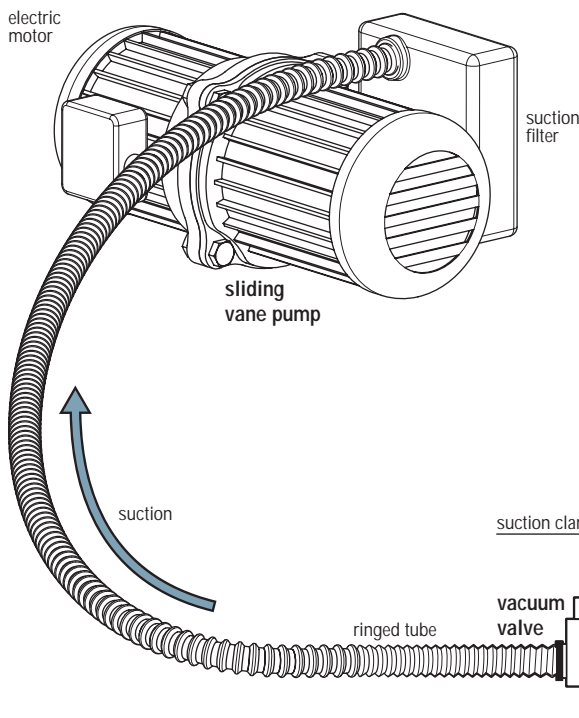

A typical application

The example shown below is a numerical control manufacturing robot, which uses suction pads to clamp porous parts. Note that the pump, which is bulky, noisy and causes vibrations, must be installed well away from the operational section of the machine. It is connected via a tube, which must have a large diameter (40 to 80 mm) to reduce line power loss, which are always heavy with vacuum.

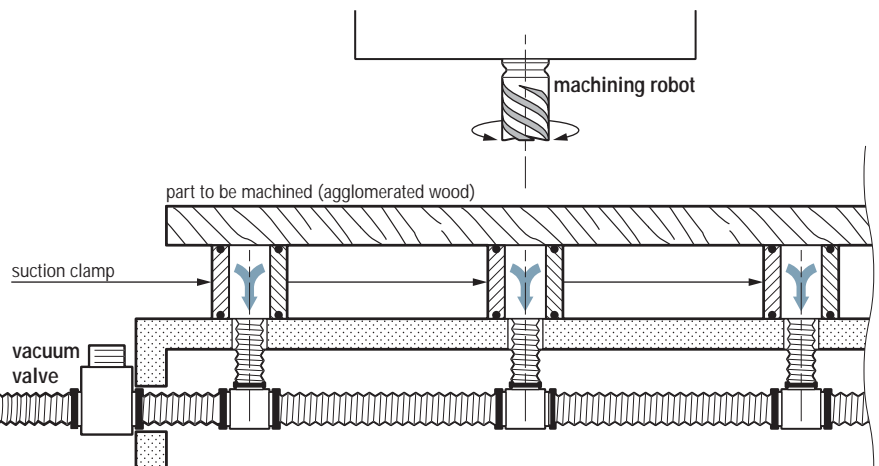

2 - Discontinuous vacuum, using venturi vacuum pumps

Venturi vacuum pump principle

Using the «venturi» effect : a nozzle of diameter \varnothing is supplied with compressed air. The air jet carries along ambient air in its turbulences and then passes the mixer on its way out. This suction of ambient air creates the depression that generates the vacuum.

Unlike rotary vacuum pumps which must turn continuously, venturi vacuum pumps can operate discontinuously, only when the suction pads require vacuum.

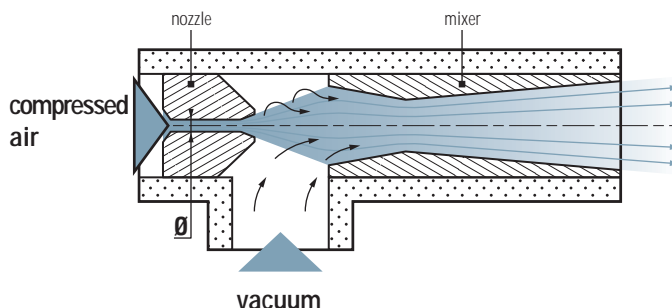

Venturi vacuum pumps

- Consumption only when needed, results in low air consumption.
- Installation very close to the suction pads.
- Suction flow and vacuum level optimized to each individual requirement.

Applications :

- All intermittent gripping operations, i.e. which do not last for complete cycle of the machine.

Venturi vacuum pump ranges

The variations in nozzle and the mixers offer an optimal range to respond all needs.

■ Nozzle diameter \varnothing

The diameter defines the force generated and therefore the suction capacity: starting from an \varnothing of 0.5mm for micro suction pads to $\varnothing = 3$ mm with a suction capacity of 400 NI/mn for several large suction pads.

■ Mixer profile

This profile defines the maximum level of vacuum achieved by the venturi. Two standard levels:

- 60% for porous material (30 to 55% vacuum)
- 90% for air-tight materials (55 to 80% vacuum)

Max. vacuum ► 2 standard levels :

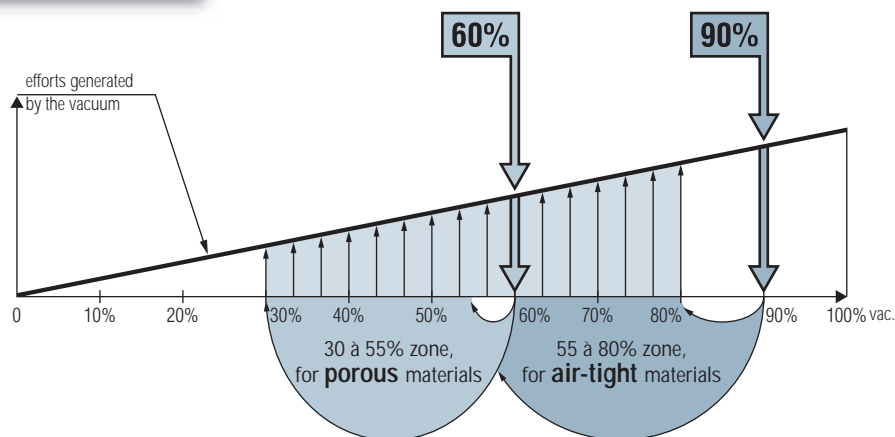

Applications and practice

Venturi vacuum pumps are used for all normal vacuum gripping applications. Compact and light, venturis may be installed close to the suction pads: no line power loss and a minimum volume to empty, resulting in short response times and minimum energy consumption.

The following pages distinguish between:

- simple, pneumatically-controlled venturi pumps, which are miniaturized for installation on suction pads.
- complete, electrically-controlled venturi pumps, for installation near to suction pads.

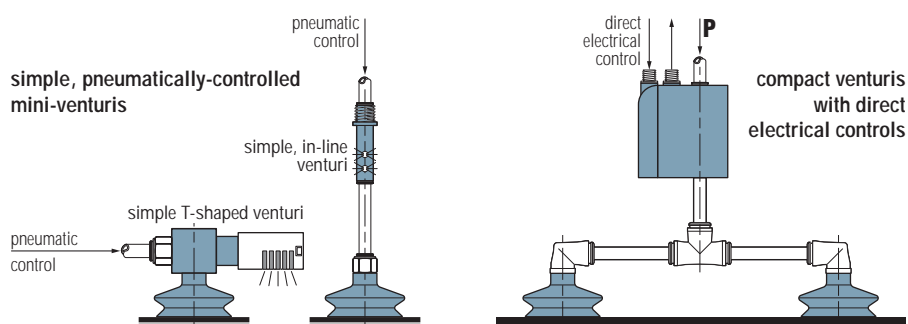

The process of defining an installation

All vacuum handling systems require a three-stage approach:

1. Defining the appropriate suction pads and fixings for the object to be gripped, the movements required, the type of object (air-tight or porous), the effort required, the cycling rate, the environment, etc.
2. Selecting the appropriate vacuum generator for the suction pads, the type of object (air-tight or porous), the required response times, etc.
3. Identifying the additional components required to connect, supply and control the installation.

The 3 steps to follow:

Step 1: the suction pads and their fixings

COVAL offers a wide range of suction pads, in three main groups: standard, specific and generic. Tailored solutions can also be developed according to a set of specifications.

Chapter 1 starts with a guide to choose and size the suction pads for a given application, among the wide offer presented in the catalogue from chapter 2 to 5.



Step 2: the vacuum generators and their controls

Selecting the perfect vacuum source for the suction pad used guarantees optimal productivity. COVAL has developed a complete range of venturi vacuum pumps using the most advanced technologies. They offer a wide suction range, optimal output, low energy consumption, reduced weight and bulk, and silent operation. Numerous integrated functions mean that they are easier and more profitable to install and use.

Chapter 6 starts with a guide to choose and configure a venturi among the many possibilities presented in the catalogue from chapter 7 to 12.



Step 3: The auxiliary components

Peripheral components are an essential addition to the vacuum network and guarantee a reliable installation.

Chapters 5 and 13 present a wide variety of auxiliary components.

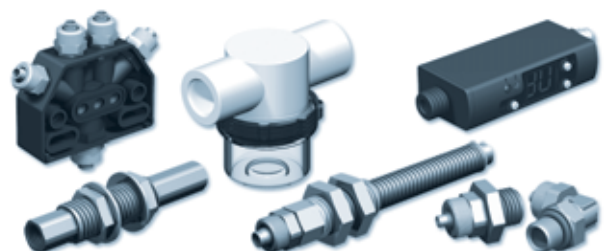

A guide to choosing your suction pads	p. 1/2 and 1/3
The COVAL range	p. 1/4 and 1/5
Index of pictograms and symbols	p. 1/6



A suction pad is a gripper which can be used to handle all sorts of objects of different weights, surfaces, shapes and dimensions.

For this reason we feel it would be helpful to explain all the parameters to be taken into consideration, in order to choose the right suction pad.

The shapes

Flat Suction Pads

- Flat suction pads without cleats

Used for handling flat or slightly rounded, rigid, smooth objects. They withstand lateral forces and can be used for vertical handling.

- Flat suction pads with cleats

Used for handling thin, flexible, deformable objects. They increase resistance to lateral forces and horizontal handling.

Suction pads with bellows

Used to handle spherical, cylindrical or egg-shaped objects. The effect of the technical characteristics increases with the number of bellows.

They can be used for gripping objects with height differences, for a ball-joint effect, to lift and to grip corners or edges.

Suction pad force calculation

The force of a suction pad is proportional to its surface under vacuum and also depends on its shape, flexibility, material and especially on the level of vacuum attained inside the suction pad.

Theoretical force

- $F(N) = \text{Surface of the suction pad (cm}^2) \times \text{Percentage of vacuum (\%)} \times 0.01013$

The force given in the COVAL suction pad tables is **the force of the suction pad measured in practice** at 90% vacuum. This figure also includes a safety factor of 2.

Actual force

As its name implies, this force represents the actual force of the suction pad when in use. In general this is 50% less than the calculated theoretical force.

This difference is explained by the distortion of the suction pad during handling (which reduces the gripping surface), and by the condition of the surface of the object being handled.

The safety factor

All the forces are given in the tables for the various ranges of suction pad. These are **actual values at 90% vacuum**, calculated with a safety factor of:

- 2 for horizontal gripping,
- 4 for vertical gripping,

For applications involving high acceleration, the safety factor will be calculated accordingly.

Diameters

The force of the suction pad and the product's available gripping surface depend on this parameter. COVAL offers standard suction pads of 1 to 600mm in diameter over all its ranges.

Parameters

You will find the most comprehensive list possible of parameters to be taken into consideration when choosing a suction pad, on the following page.

Parameters to be taken into consideration when choosing a suction pad

Shape of the load	Flat • Rounded • Cylindrical • Egg-shaped • Spherical, etc.
Type of material of the load	Porous • Air-tight • Deformable • Rigid • Fragile, etc.
Condition of the surface of the load	Smooth • Granular • Ridged • Abrasive, etc.
Appearance of the load	Damp • Oily • Dusty • Viscous • Dry, etc.
Weight of the load	Heavy • Light, etc.
Temperature of the load	From -40 to 250°C / -40 to 482°F depending on the materials chosen.
Direction of gripping	Horizontal • Vertical • Over corners • Height differences, etc.
Type of grip	Handling • Lifting • Holding • Unfolding ... objects.
Available surface	Depends on the load
Cycle time	Accelerations

COVAL materials

To meet the constraints of industrial applications, COVAL has a wide range of both standard and specific materials. COVAL can also study new materials based on specific requirements of your applications.

Properties of the materials

Materials	Shore Hardness	Flexibility	Abrasion resistance	UV & weather resistance	Oil resistance	Heat resistance (in °C)	Food compatibility	Color
NBR: Nitrile	60	+	+	-	++	0 to 80	-	Black
SI: Translucent Silicone	50	+++	-	+++	-	-40 to 220	+++	Translucent
SIT5: Translucent Silicone	50	+++	-	+++	-	-40 to 220	+++	Translucent
NR: Natural Rubber	50	+++	++	--	--	-20 to 70	+	Grey
STN: Siton®	60	+	++	-	++	0 to 160	-	Blue
PUB: Polyurethane	60	+	+++	++	++	-20 to 80	-	Blue
NBR A : Antistatic Nitrile	60	+	+	-	++	0 to 80	-	Black + blue spot
SIA: Antistatic Silicone	60	++	-	+++	-	-20 to 200	+	Black + red spot
FPM: Viton	60	+	+	+++	+++	-20 to 250	-	Black
NE: Neoprene	60	+	+	++	+	-10 to 80	-	Black

SITON®

The COVAL laboratory has developed a new material: SITON®. SITON® is a silicone-free material which therefore does not leave a mark and was specially developed for handling hot objects that are waiting to be painted.

- SITON® can withstand maximum temperature of 320 °F.
- SITON® has good resistance to abrasion.

Example of an application: Unmolding paintable plastic parts.

For all your everyday needs, VP, VPG, VSA and VS series







Standard Suction pads

COVAL QUALITY

Standard suction pads are suitable for all types of applications in areas of activity such as packaging, plastics, agri-food, sheet-metal working, etc.

These suction pads satisfy very diverse specifications thanks to a wide range of shapes, diameters and materials.

COVAL offers a full range of fittings adapted to suction pads and compatible with all types of applications.





Series	Technical Data	Advantages/Applications
VP 	<ul style="list-style-type: none"> Flat suction pads Ø 5 to 95mm 6 standard materials 	<ul style="list-style-type: none"> High tensile force and precise gripping and releasing High resistance to lateral forces allowing vertical handling Full range of fittings and shut-off valves
VPG 	<ul style="list-style-type: none"> Extra-flat suction pads Ø 1 to 200mm 6 standard materials 	<ul style="list-style-type: none"> Highly precise gripping and releasing of the load High throughput rates
VSA 	<ul style="list-style-type: none"> Suction pads with 1.5 bellows Ø 5 to 78mm 6 standard materials 	<ul style="list-style-type: none"> Combines the advantages of flat suction pads with added angle, flexibility and precision Used for gripping slightly concave or convex parts Full range of fittings
VS 	<ul style="list-style-type: none"> Suction pads with 2.5 bellows Ø 5 to 88mm 8 standard materials 	<ul style="list-style-type: none"> Recommended for gripping products on different planes (wide deflection) or cylindrical objects gripped at an angle (ball-joint effect). Full range of fittings
VPO 	<ul style="list-style-type: none"> Flat oblong suction pads from 2x4mm to 30x90mm 3 standard materials 	<ul style="list-style-type: none"> Used for handling elongated products such as pens, tubes, bottles, bulbs and flat or cylindrical objects etc.
C 	<ul style="list-style-type: none"> Full range of shapes (flat, bellows, oblong) Ø 35 to 125mm and 25x65mm to 70x140mm Integrated M3/8G, F38G or Square 32 fittings Structure and internal cleats 	<ul style="list-style-type: none"> Textured suction pads for gripping thin sheets Non-slip cleats ensure optimum positioning of oily sheet metal Extreme resistance to slipping, Air-tight integrated fittings Ideal for robotic applications
VSBM 	<ul style="list-style-type: none"> Foam rings Materials: Nitrile and silicone Can be adapted to standard suction pads 	<ul style="list-style-type: none"> They can be bonded under a suction pad to allow products with an irregular or even ridged surface to be gripped Sawn wood, metal sheets, flat surfaces with bumps or hollows (all types of granular surface)











For your specific needs: MVS, VSO, VPA, VPR, ...

Special purpose suction pads

Thanks to its technological prowess and collaboration with its customers in different branches, COVAL supplies solutions for vacuum handling through a wide range of special purpose suction pads.

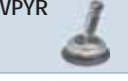
E.g. handling eggs, CDs, bottles, paper, cakes, etc.

Series	Technical Data	Advantages/Applications
MVS 	<ul style="list-style-type: none"> Suction pads with 1.5 - 2.5 and 3.5 bellows 4 models Silicone: Food compatibility 	<ul style="list-style-type: none"> Used to grip delicate objects. Very flexible lip (opening bags, gripping tins and flexible aluminum or plastic bottles, etc.) High throughput rate Gripping of flexible products
VSO 	<ul style="list-style-type: none"> Suction pads with 2.5 and 3.5 bellows 3 models Silicone: Food compatibility 	<ul style="list-style-type: none"> Range specially designed for handling eggs Very flexible lip Different shapes of suction pad
VSD, VSE, VSP, VSB 	<ul style="list-style-type: none"> Suction pads with 2.5 to 5.5 bellows 13 models Silicone: food compatibility 	<ul style="list-style-type: none"> Range specially developed for gripping delicate objects such as cakes (buns, biscuits, etc.) Specific shapes and shore hardness depending on the applications Temperature resistance: - 40 °F to 428 °F
VSBO 	<ul style="list-style-type: none"> Suction pads with 4.5 bellows 2 models High tensile force Highly flexible and long stroke 	<ul style="list-style-type: none"> Used to grip 75cl bottles and Magnums. Bottles gripped from the side, vertical and horizontal handling Suction pad with stainless steel reinforcement in the bellows





Series	Technical Data	Advantages/Applications
VPA 	<ul style="list-style-type: none"> Flat suction pads 9 models Very flexible lip Natural rubber and silicone (food compatibility) 	<ul style="list-style-type: none"> Range of suction pads with very flexible lip used to handle very flexible materials Very resistant to abrasion (for paper, cardboard) Very flexible gripping lip which molds to the shape of the object to be handled
VPR 	<ul style="list-style-type: none"> Flat suction pads 4 models Natural rubber 	<ul style="list-style-type: none"> Range of suction pads designed for mailing applications Envelope stuffing, film-wrapping, mailing (picking) Very resistant to abrasion
VPAG 	<ul style="list-style-type: none"> Curved suction pads 2 models Natural rubber 	<ul style="list-style-type: none"> Thanks to very flexible lips and a curved shape, the VPAG range is adapted to gripping flexible materials such as labels or sheets of paper or shaped objects Very resistant to abrasion
VPV, VSAV, VSV, VSAOV 	<ul style="list-style-type: none"> Available in the following versions: <ul style="list-style-type: none"> Flat cylindrical, 1.5 and 2.5 bellows Oblong, 1.5 bellows Material: polyurethane 	<ul style="list-style-type: none"> Exceptionally resistant to abrasion For handling cardboard boxes or paper (very abrasive) in packaging machines with high throughput Excellent resistance to tearing
VPS 	<ul style="list-style-type: none"> Flat suction pads with extra-long shafts 4 models Materials: nitrile and silicone 	<ul style="list-style-type: none"> VPS suction pads are used to handle fragile objects Suction pads with extra-long shafts
VCD, VPCD 	<ul style="list-style-type: none"> Flat suction pads 5 models Material: silicone 	<ul style="list-style-type: none"> Specifically used to handle delicate objects at a high throughput rate (CDs, DVDs) Excellent resistance to high temperatures (silicone)
VPYR 	<ul style="list-style-type: none"> Flat suction pads with ball-joint system 4 models (Ø50 to 100mm) Materials: nitrile and silicone 	<ul style="list-style-type: none"> The range of ball-joint suction pads is recommended for gripping curved or rotating products which requires a lot of force and mechanical resistance
SPL 	<ul style="list-style-type: none"> "Heavy load" flat suction pads 5 models (Ø240 to 600mm) Materials: nitrile and silicone 	<ul style="list-style-type: none"> SPL suction pads are used to handle heavy loads such as metal sheets or glass panels. They have internal cleats allowing them to handle thin metal sheets without distorting them and for vertical handling (non-slip)
STEEL 	<ul style="list-style-type: none"> Flat suction pads with a bonded foam seal 9 cylindrical models (Ø 150 to 580mm) 9 oblong models (175x115 to 705x385mm) 	<ul style="list-style-type: none"> For horizontal handling of heavy loads (thick metal sheets) or objects with an uneven surface such as concrete slabs or wood, etc. Wide choice of dimensions
VA 	<ul style="list-style-type: none"> Flat suction pads with a removable foam seal 5 cylindrical models (Ø 250 to 360mm) 5 oblong models (300x200 to 420x270mm) 	<ul style="list-style-type: none"> For horizontal handling of heavy loads (thick metal sheets) or objects with an uneven surface such as concrete slabs or wood, etc. (removable seal = easier maintenance)

Simple and cost-effective

Generic suction pads for replacement

COVAL QUALITY

Some of our customers have sometimes used suction pads made by other manufacturers adapted to their applications. To satisfy them we have developed a range of generic suction pads which are 100% compatible with their application. Please contact your COVAL correspondent for further information regarding generic solutions.

Series	Technical Data	
VPU 	<ul style="list-style-type: none"> Flat suction pads Ø 6 to 50 mm 2 standard materials (Nitrile and silicone) 	<ul style="list-style-type: none"> Range of generic VPU flat suction pads.
VSAB 	<ul style="list-style-type: none"> Suction pads with 1.5 bellows Ø 5 to 50mm 2 standard materials (Nitrile and silicone) 	<ul style="list-style-type: none"> Range of generic VSAB suction pads with 1.5 bellows.
VSAG 	<ul style="list-style-type: none"> Suction pads with 1.5 bellows Ø 10 to 150mm 4 standard materials 	<ul style="list-style-type: none"> Range of generic VSAG suction pads with 1.5 bellows.
VSAJ 	<ul style="list-style-type: none"> Suction pads with 1.5 bellows Ø 15 to 30mm 2 standard materials (Nitrile and silicone) 	<ul style="list-style-type: none"> Range of generic VSAJ suction pads with 1.5 bellows .
VSG 	<ul style="list-style-type: none"> Suction pads with 2.5 bellows Ø 5 and 7mm 5 standard materials 	<ul style="list-style-type: none"> Range of generic VSG suction pads with 2.5 bellows.

You will find the symbols and pictograms described below in the "Suction pads" chapters to help you select the range of suction pads best suited to your application.

Branch-specific applications

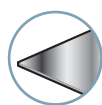

Metal

- For handling rigid, smooth, flat objects (e.g. Sheet metal, glass or plastic panels). Heavy loads
- Oily objects
- High throughput
- High acceleration

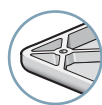

Plastic

For handling plastic objects and requiring resistance to high temperatures, mark-free (e.g. COVAL-developed material, Siton®).



Eggs

For handling requiring food compatibility, a very flexible lip and a specific shape of suction pad.

- Gripping eggs



Bottles

Gripping concave shapes and requiring strong vertical lifting force.

- For handling 75cl bottles or Magnums

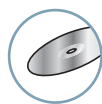

CD / DVD

Handling CDs or DVDs requires a specific shape of suction pad to meet the throughput and positioning constraints.

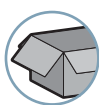

Packaging

For handling wrapped products for packaging, cardboard products. Shaping cardboard, palletization, transfer, Pick & Place.

- Precision
- Abrasion

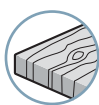

Wood

For handling materials with a slightly deformed, rough gripping surface requiring a foam seal to compensate for the unevenness and ensure air-tightness.



Cakes

For handling requiring food compatibility, a very flexible lip and a specific shape of suction pad.

- Gripping buns, biscuits, etc.



Paper/picking

For handling paper, and labels and requiring high resistance to abrasion and a very flexible lip to grip flexible materials.

- Envelope stuffing, film-wrapping

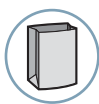

Bags

Gripping very flexible, deformable materials (plastic or paper).

- e.g. blister, bagging, etc.

Types of use



Flat surfaces, all thicknesses



Flat surfaces, thin sheets



Rounded surfaces



Sheet metal (unstacking)



Flexible materials



Vertical handling



Granular surfaces

Tables

Model or reference	Internal volume	Tensile force	Slipping force	Minimum convex curve radius	Minimum concave curve radius	Weight	See page

COVAL QUALITY

Standard suction pads are suitable for all types of applications in areas of activity such as packaging, plastics, agri-food, sheet-metal working, etc.

These suction pads satisfy very diverse specifications thanks to a wide range of shapes, diameters and materials.

COVAL offers a full range of fittings adapted to suction pads and compatible with all types of applications.

VP

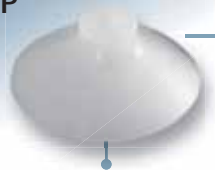

- Flat suction pads
- Ø 5 to 95mm
- 6 standard materials

P_{2/2}

- High tensile force and precise gripping and releasing
- High resistance to lateral forces allowing vertical handling
- A full range of fittings and shut-off valves

VSA

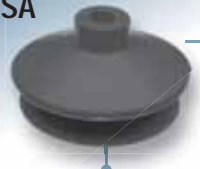

- Suction pads with 1.5 bellows
- Ø 5 to 78mm
- 6 standard materials

P_{2/6}

- VSA series suction pads with bellows combine the advantages of flat suction pads with more deflection, flexibility and precision
- Used for gripping slightly concave or convex parts
- Full range of fittings

VPO



- Flat oblong suction pads
- From 2x4mm to 30x90mm
- 3 standard materials

P_{2/10}

- Used for handling elongated products such as pens, tubes, bottles, bulbs and flat or cylindrical objects etc.

VSBM



- Foam rings
- Materials: nitrile and silicone
- Can be adapted to standard suction pads

P_{2/14}

- The strip of foam bonded under a suction pad allows products with an irregular or even ridged surface to be gripped
- Sawn wood, metal sheets, flat surfaces with bumps or hollows (all types of granular surface)

Male and female fittings

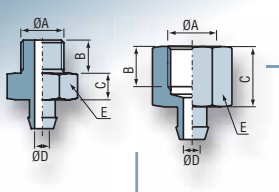

- Hollow shaft fittings
- Hollow screws + adapters
- Riveted fittings
- Screwed fittings

P₂₂

- Drawings with dimensions of fittings

VPG

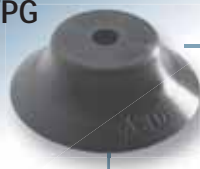

- Extra-flat suction pads
- Ø 1 to 200mm
- 6 standard materials

P_{2/4}

- Highly precise gripping and releasing of the load
- High throughput rates

VS



- Suction pads with 2.5 bellows
- Ø 5 to 88mm
- 8 standard materials

P_{2/8}

- VS series suction pads with bellows are recommended for gripping products on different planes (wide deflection) or cylindrical objects gripped at an angle (ball-joint effect).
- Full range of fittings

C



- Full range of shapes (flat, bellows, oblongs)
- Ø 35 to 125mm and 25x65mm to 70x140mm
- Integrated M3/8G, F38G or Square 32 fittings
- Structure and internal cleats

P_{2/11}

- Textured suction pads for gripping thin sheets
- Non-slip cleats ensure optimum positioning of oily sheet metal
- Extreme resistance to slipping
- Air-tight integrated fittings
- Ideal for automated applications

Assembly diagrams

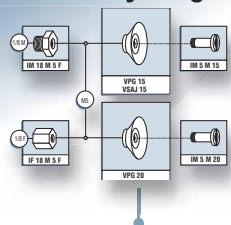

- By suction pad series
- By diameter of suction pad

P_{2/15}

- This visual tool enables you to quickly and easily choose the fittings according to the series and diameter of the suction pad



Branch-specific applications

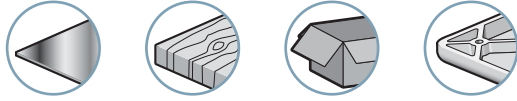

Presentation

VP series flat suction pads are specially recommended for handling flat, rigid, smooth products.

- High tensile force
- High resistance to lateral forces allowing vertical handling.
- High degree of precision

Types of use



Materials

NBR	Nitrile	STN	Siton®
SIT5	Translucent silicone	FPM	Viton
SIA	Antistatic silicone	NE	Neoprene
NR	Natural rubber		

Icon	Ø (mm)	Volume (cm³)	Force (N) (1)	Force (N) (1)	NBR	SIT5	SIA	NR	STN	FPM	NE
VP 5	5.5	0.03	0.65	0.32	■	■	■		✱		
VP 8	7.5	0.04	1.5	0.75	■	■	■		■		
VP 10	10	0.05	2.2	1.1	■	■			✱		
VP 15	15	0.18	5.1	2.5	■	■			■		
VP 20	20	0.44	8.5	4.2	■	■		■	■	■	
VP 25	25	0.7	13	6.5	■	■			■		
VP 26	26	1.5	15.5	7.7	■	■			■		
VP 30	30	2.9	22	11	■	■			■		
VP 35	35	2.7	32	16	■	■			✱	■	
VP 40	40	4	37	18.5	■	■		■	■		
VP 50	52	7	53	26.5	■	■		■	■		
VP 60	60	7.3	80	40	■	■			✱		
VP 75	75	16	140	70	■	■		■	✱		
VP 95	95	47.5	170	85		■			✱	■	■

(1) Actual force of the suction pad in use with a 90% vacuum and including a safety factor of 2 for horizontal handling and a factor of 4 for vertical handling.

■ Standard
✱ On request

Choice of fittings

Icon (Ø)	Group	Icon	M3M	M5M	M6M	M8M	M10M	1/8F	1/8M	10/32 M	1/4F	1/4M	3/8M	1/2M
5	1	2/15	■	■	■			■	■	■				
8... 25	1	2/15		■	■			■	■	■				
26... 60	2	2/16		■	■	■	■	■	■		■	■		
75, 95	3	2/17					■		■		■	■	■	■

■ Standard

Fitting: M = male
F = female

For all orders, please specify : Model + Diameter + Material AND factory-crimped fitting (optional)



or: Model + Diameter + Material + choice of removable fitting

1: Model	2: Diameter	3: Material	4: Factory-crimped fitting			
VP	5 ... 95	NBR ... Please refer to the table	For Ø26... 60mm suction pad		For Ø75... 95mm suction pad	
			IM14	1/4G male	IM14	1/4G male
			IF14	1/4G female	IF14	1/4G female
					IM38	3/8G male

E.g. VP 50 NBR IF14 (VP series suction pad, Diameter 50, Nitrile with factory-crimped 1/4G female fitting)

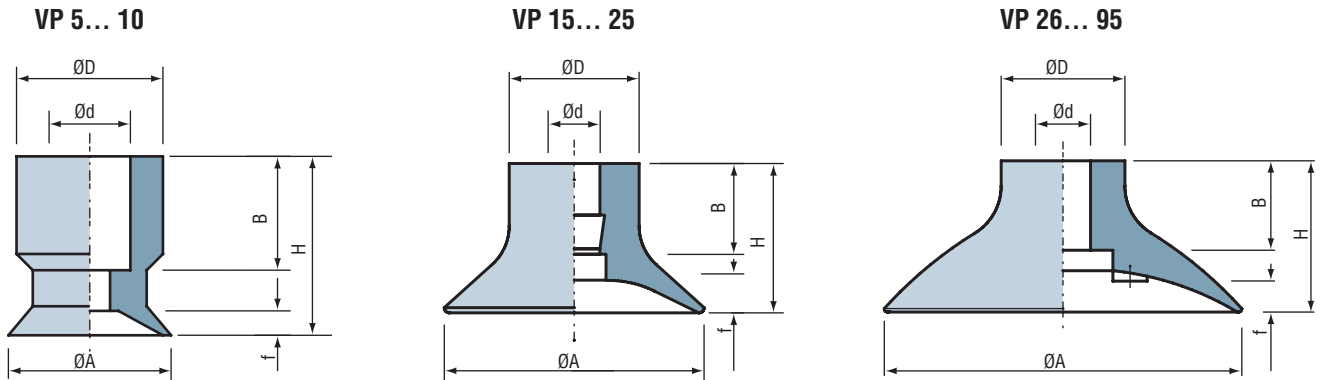
Dimensions



	Ø A (mm)	H (mm)	Ø d (mm)	Ø D (mm)	f ⁽¹⁾ (mm)	B (mm)	 (g)
VP 5	5.5	9	4	7	1	7	0.3
VP 8	7.5	10	5	9	1.3	7	0.4
VP 10	10	10.5	4.4	9	1.5	7	0.5
VP 15	15	11	4	9	2.25	7	0.7
VP 20	20	11.5	4	10	3	7	1.2
VP 25	25	12	4	10	3	7	1.4
VP 26	26	19.5	8	16	3	13	3.7
VP 30	30	19	8	16	2.5	13	4
VP 35	35	20	8	16	3	13	5.6
VP 40	40	20	8	16	3	13	9
VP 50	52	22	8	18	4.5	13	14
VP 60	60	22	8	18	4.5	13	16
VP 75	75	32	12	23	4.5	20	33
VP 95	95	38	12	25	12	20	50

The values represent the average characteristics of our products.

(1) f = Deflection of the suction pad.

Types of assembly

Factory-crimped fitting:

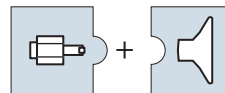

Hollow shaft fitting:

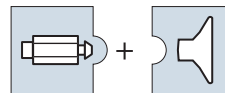

Removable fitting: (adapter and hollow screw)

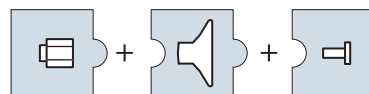

Assembly diagrams

COVAL suction pads can be assembled in a wide variety of configurations. see pages 2/15 to 2/17.

Accessories

To optimize the use of your suction pads, Coval offers a comprehensive range of accessories (feelers, spring extensions, and feeder systems, etc.), see chapters 5 and 13.

VPG series

Extra-flat suction pads Ø 1 to 200mm



Branch-specific applications



Presentation

The profile of the VPG series extra-flat suction pads provides for accuracy in load gripping and speeds up throughput rates. These suction pads are used for flat surfaces only.

2

Types of use



Materials

NBR Nitrile
SI Silicone
STN Siton®
PUB Blue polyurethane
SIA Antistatic silicone
FPM Viton

	Ø (mm)	Volume (cm ³)	Force (N) ⁽¹⁾	Force (N) ⁽¹⁾	R _{min} (mm)	NBR	SI	STN	PUB	SIA	FPM
VPG 1	1	0.00015	0.03	0.015	2	■	■	✱	✱		
VPG 1.5	1.5	0.00053	0.06	0.03	2	■	■	✱	✱		
VPG 2	2	0.00073	0.11	0.06	2	■	■	■	■	■	
VPG 3.5	3.5	0.0022	0.34	0.17	8	■	■	■	■	■	■
VPG 5	5	0.005	0.67	0.34	8	■	■	■	■	■	
VPG 6	6	0.008	0.98	0.49	8	■	■	■	■	■	
VPG 8	8	0.03	1.7	0.85	10	■	■	■	■	■	■
VPG 10	10	0.07	2.8	1.40	13	■	■	■	■	■	■
VPG 15	15	0.2	6.5	3.3	13	■	■	■	■	■	■
VPG 15A	15	0.2	6.5	3.3	13	■	■	■	■	✱	✱
VPG 20	20	0.5	12.2	6.1	20	■	■	■	■	■	■
VPG 20B	20	0.5	12.3	6.5	20	■	■	■	■	✱	✱
VPG 25	25	1.1	16.7	8.4	25	■	■	■	■	■	
VPG 30	30	1.4	22.7	11.4	40	■	■	■	■		■
VPG 35	35	2.9	33	16.5	50	■	■	■	■		
VPG 40	40	3.8	48	24	50	■	■	■	■		■
VPG 50	50	5.3	75	37.5	75	■	■	■	■		■
VPG 60	60	12	123	61.5	100	■	■	■	■		■
VPG 60S	60	12	123	61.5	100	■	■	■	■		■
VPG 80	80	26.9	198	99	150	■	■	■	■		■
VPG 80S	80	26.9	198	99	150	■	■	■	■		■
VPG 95	95	41	280	140	200	■	■	■	■		■
VPG 95S	95	41	280	140	200	■	■	■	■		■
VPG 120	120	141	365	182.5	365	■	■	■	■		
VPG 150	150	230	590	295	380	■	■	■	■		
VPG 200	200	384	1050	525	430	■	■	■	■		

(1) Actual force of the suction pad in use with a 90% vacuum and including a safety factor of 2 for horizontal handling and a factor of 4 for vertical handling.

■ Standard / ✱ On request

Choice of fittings

		M3 M	M5 M	M5 F	M6 M	M8 M	M10 M	M10 125 pitch	1/8 F	1/8 M	1/4 F	1/4 M	1/2 F
1, 1.5	2/18	■											
2, 3.5	2/18	■	■										
15A, 5... 10	2/18		■	■					■	■			
15, 20	2/19		■						■	■			
20B, 25... 50	2/20				■	■	■		■	■	■	■	
60... 95	2/21							■			■	■	
60S... 95S	2/21										■		
120... 200	2/21												■

■ Standard Fitting: M = male F = female

For all orders, please specify:

Model + Diameter + Material

E.g. VPG 50 FPM (VPG series, Diameter 50, in Viton)

1: Model

VPG

2: Diameter

1 ... 200

3: Material

NBR See table

Dimensions

VPG 1 - 1.5

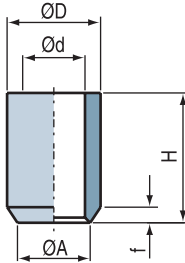

VPG 15A, VPG 2... 10

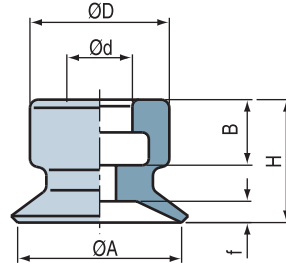

VPG 20B, VPG 15... 50

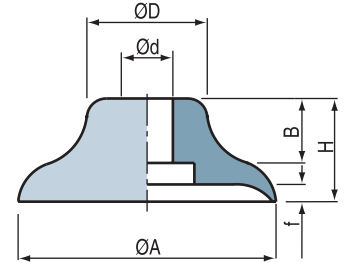

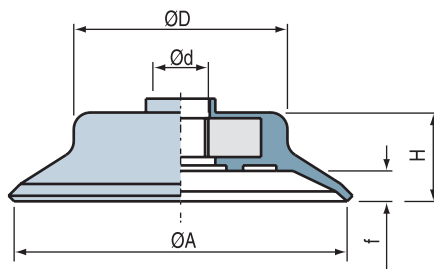

VPG 60 - 95

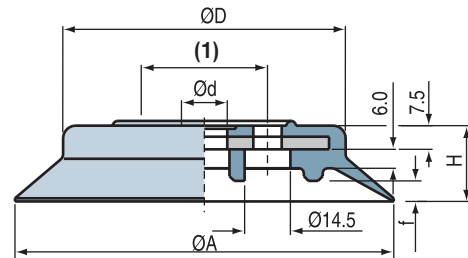

VPG 120... 200



(1) 4 holes
Ø9 on Ø40

	Ø A (mm)	H (mm)	Ø d (mm)	Ø D (mm)	f ⁽¹⁾ (mm)	B (mm)	 (g)
VPG 1	1	1.6	0.8	1.2	0.2	-	
VPG 1.5	1.5	2.5	1.2	1.8	0.3	-	
VPG 2	2	4	2	4	0.5	2.5	
VPG 3.5	3.5	4	2	4	0.5	2.5	
VPG 5	5	6.5	4	7.5	0.8	4	
VPG 6	6	6.5	4	7.5	0.8	4	
VPG 8	8	7	4	8	1.2	4	0.26
VPG 10	10	7.5	4	8.7	1.5	4	0.36
VPG 15	15	8	4.5	12	1.9	2.5	0.9
VPG 15A	15	8	4	9	1.9	4	0.9
VPG 20	20	10	4.5	15	2.3	4.5	1.93
VPG 20B	20	10	6	15	2.3	7	2.5
VPG 25	25	14	6	16	3	7	3
VPG 30	30	12	6	15	2	7	4
VPG 35	35	14	6	20.5	3	7	6.8
VPG 40	40	14	6	23.5	3.5	7	8.4
VPG 50	50	15	8	29	4	7	13
VPG 60	60	16	M10x125	38	5	-	25
VPG 60S	60	16	1/4G	38	5	-	25
VPG 80	80	18	M10x125	53	6	-	55
VPG 80S	80	18	1/4G	53	6	-	55
VPG 95	95	19	M10x125	68	6	-	96
VPG 95S	95	19	1/4G	68	6	-	96
VPG 120	120	24.5	14.5	89.5	6	-	242
VPG 150	150	30.5	13	105	9	-	480
VPG 200	200	35.5	13	143	12.5	-	840

The values represent the average characteristics of our products.

(1) f = Deflection of the suction pad.

Assembly diagrams

COVAL suction pads can be assembled in a wide variety of configurations.

see pages 2/18 to 2/21.

Accessories

To optimize use of your suction pads, Coval offers a comprehensive range of accessories (feelers, spring extensions, and feeder systems, etc.) see chapters 5 and 13.



Branch-specific applications

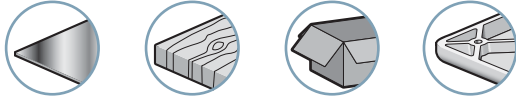

Types of use

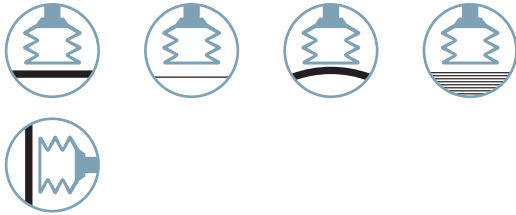

Presentation

- VSA series suction pads with bellows combine the advantages of flat suction pads with increased deflection, flexibility and precision. Flexibility
- Precision
- Deflection

Materials

- | | | | |
|------|----------------------|-----|---------------------|
| NBR | Nitrile | STN | Siton® |
| SIT5 | Translucent silicone | PUB | Blue polyurethane |
| NR | Natural rubber | SIA | Antistatic silicone |

	Ø (mm)	Volume (cm³)	Force (N) (1)	Force (N) (1)	R _{min} (mm)	NBR	SIT5	NR	STN	PUB	SIA
VSA 5	5.5	0.04	0.68	0.34	-	■	■	■	■	■	
VSA 11	11	0.225	2.4	1.2	10	■	■	■	■	■	■
VSA 14	13	0.42	3.5	1.75	13	■	■	■	■	■	
VSA 16	16	0.75	3.7	1.85	20	■	■	■	■	■	
VSA 18	18	0.76	6.1	3.05		■	■	■	■	■	
VSA 20	19	1.15	7.7	3.85	30	■	■	■	■	■	
VSA 22	22	1.4	8.5	4.25	25	■	■	■	■	■	
VSA 25	24	3.15	11	5.5	20	■	■	■	■	■	
VSA 26	25	3.9	15	7.5		■	■	■	■	■	
VSA 33	33	4.75	19.2	9.6	40	■	■	■	■	■	
VSA 43	43	9.25	28	14	60	■	■	■	■	■	
VSA 53	53	26.25	59	29.5	75	■	■	■	■	■	
VSA 63	63	39	82	41	75	■	■	■	■	■	
VSA 78	78	76	152	76	70	■	■	■	■	■	

(1) Actual force of the suction pad in use with a 90% vacuum and including a safety factor of 2 for horizontal handling and a factor of 4 for vertical handling.

Choice of fittings

	Group		M3M	M5M	M6M	M8M	M10M	1/8F	1/8M	10/32 M	1/4F	1/4M	3/8M	1/2M
5	1	2/15	■	■	■			■	■	■				
11... 25	1	2/15		■	■			■	■	■				
26... 63	2	2/16		■	■	■	■	■	■		■	■		
78	3	2/17					■		■		■	■	■	■

■ Standard

Fitting: M = male
F = female

Note:

Ø 110 and 150mm available in the VSA G range of suction pads (page 4/6).

For all orders, please specify : Model + Diameter + Material AND factory-crimped fitting (optional)
or: Model + Diameter + Material + choice of removable fitting



1: Model	2: Diameter	3: Material
VSA	5 ... 78	NBR ... Please refer to the table

4: Factory-crimped fitting			
For Ø26... 63mm suction pad		for Ø78mm suction pad	
IM14	1/4G male	IM14	1/4G male
IF14	1/4G female	IF14	1/4G female
		IM38	3/8G male

E.g. VSA 78 NBR IM14 (VSA series suction pad, Diameter 78, in Nitrile with 1/4G male fitting)

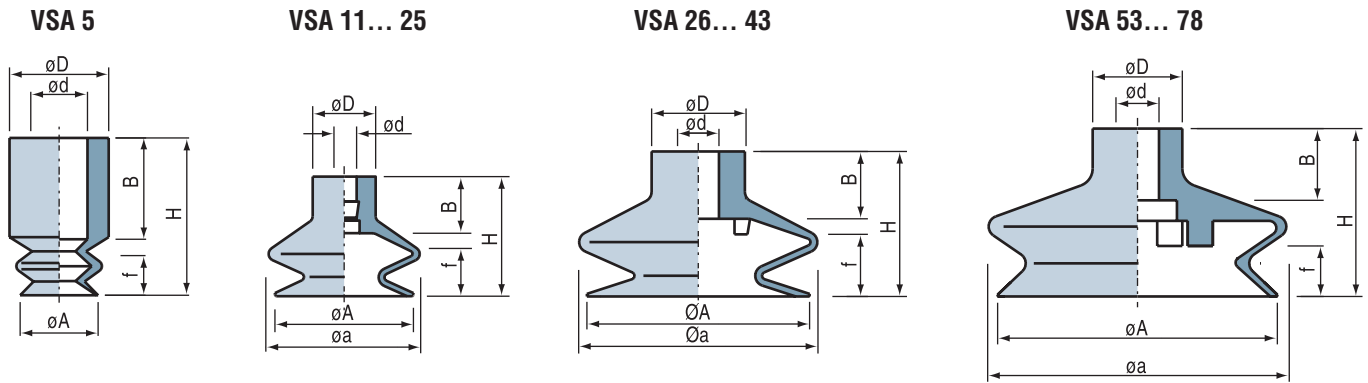
Dimensions



	Ø A (mm)	H (mm)	Ø a (mm)	Ø d (mm)	Ø D (mm)	f ⁽¹⁾ (mm)	B (mm)	 (g)
VSA 5	5.5	11	6	4	7	2	7	0.5
VSA 11	11	16	12.2	4	10	5.5	9	0.7
VSA 14	13	16	14	4	10	5	9	1
VSA 16	16	19	17.3	4	10	8.5	9	1.2
VSA 18	18	16.5	18	4	10	5	9	1.5
VSA 20	19	16	20	4	10	5	9	1.6
VSA 22	22	19	24	4	10	8	9	1.8
VSA 25	24	23	25	4	10	12	9	2.8
VSA 26	25	25	30	8	16	6	13	6.1
VSA 33	33	27.5	36.2	8	18	11	13	6.4
VSA 43	43	28	46	8	18	12.5	13	10
VSA 53	53	34	59	8	18	15	13	15
VSA 63	63	34	67	8	18	15	13	28
VSA 78	78	46.8	83	12	25	14	20	42

The values represent the average characteristics of our products.
 (1) f = Deflection of the suction pad.

Granular surfaces

For handling objects with a granular or textured gripping surface, use VSA suction pads with the VSBM foam strip option (see page 2/14).

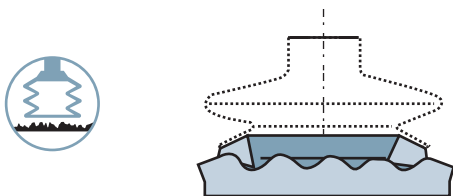

Types of assembly

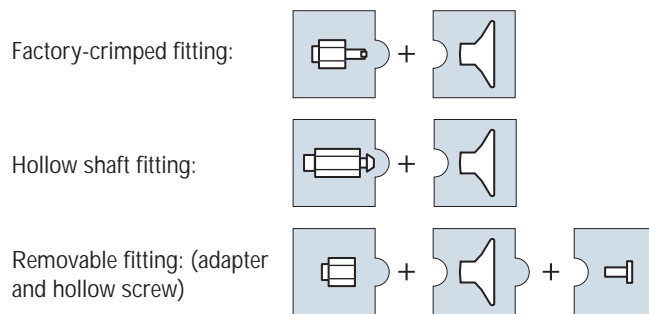

Assembly diagrams

COVAL suction pads can be assembled in a wide variety of configurations. see pages 2/15 to 2/17.

Accessories

To optimize use of your suction pads, Coval offers a comprehensive range of accessories (feelers, spring extensions, and feeder systems, etc.) see chapters 5 and 13.



Branch-specific applications

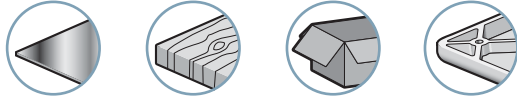

Presentation

VS series suction pads with bellows are recommended for gripping products on different planes (wide deflection) where they can replace spring systems, and for gripping spherical or cylindrical objects gripped at an angle (ball-joint effect).

- Large deflection (stroke)
- Flexibility

Types of use



Materials

NBR	Nitrile	PUB	Blue polyurethane
SIT5	Translucent silicone	NBRA	Antistatic nitrile
NR	Natural rubber	SIA	Antistatic silicone
STN	Siton®	SIHT	High temperature silicone

Icon	Ø (mm)	Volume (cm³)	Force (N) (1)	R _{min} (mm)	NBR	SIT5	NR	STN	PUB	NBRA	SIA	SIHT
VS 5	5	0.04	0.66	8	■	■		■	✱			
VS 6	6	0.04	0.68	8	■	■		✱	✱			
VS 7	7	0.0425	1.3	8	■	■		■	✱			
VS 9	9	0.15	1.5	10	■	■	■	■	■	■	■	■
VS 12	12	0.54	3.9	13	■	■	■	■	■			
VS 14	14	0.975	4.1	15	■	■	■	■	■			
VS 18	17.5	1.35	6.1	20	■	■	■	■	■			
VS 20	20	2	6.4	30	■	■	■	■	■			
VS 25	25	5.4	9	30	■	■	■	■	■			
VS 26	25	6.1	15	30	■	■	■	■	■			
VS 32	32	10	16.8	35	■	■	■	■	■			
VS 42	42	19.5	29	75	■	■	■	■	■			
VS 52	52	36	40	75	■	■	■	■	■			
VS 62	62	72.5	57	75	■	■	■	■	■			
VS 88	88	165	184	100	■	■	■	✱	✱			

(1) Actual force of the suction pad with a 90% vacuum and a safety factor of 2 included.

- Standard
- ✱ On request

Choice of fittings

Icon (Ø)	Group	Icon	M3M	M5M	M6M	M8M	M10M	1/8F	1/8M	10/32 M	1/4F	1/4M	3/8M	1/2M
5, 6	1	2/15	■	■	■			■	■	■				
7... 25	1	2/15		■	■			■	■	■				
26... 62	2	2/16		■	■	■	■	■	■		■	■		
88	3	2/17					■		■		■	■	■	■

■ Standard

Fitting: M = male
F = female

For all orders, please specify : Model + Diameter + Material AND factory-cripped fitting (optional)
OR: Model + Diameter + Material + choice of removable fitting

1: Model	2: Diameter	3: Material	4: Factory-cripped fitting			
VS	5 ... 88	NBR ... Please refer to the table	For Ø26... 62 mm suction pad		For Ø88mm suction pad	
			IM14	1/4G male	IM14	1/4G male
			IF14	1/4G female	IF14	1/4G female
					IM38	3/8G male

E.g. VS 18 SIT5 IF14
(VS series suction pad, Diameter 18, translucent silicone with factory-cripped 1/4G female fitting)

Dimensions

VS 5... 9

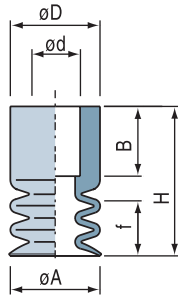

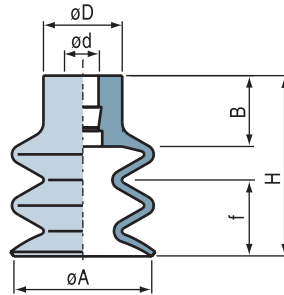

VS 12... 25

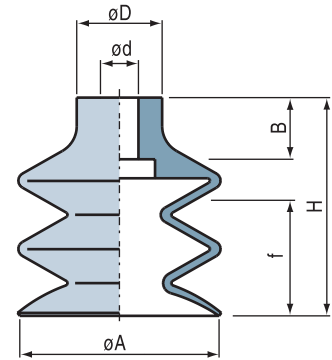

VS 26... 88



	Ø A (mm)	H (mm)	Ø d (mm)	Ø D (mm)	f (mm)	B (mm)	 (g)
VS 5	5	13.5	4	7	3	8	0.5
VS 6	6	13.2	4	7	3	7	0.5
VS 7	7	13.5	4.7	9	3	6	0.5
VS 9	9	15	4.4	9	3	7	0.6
VS 12	12	21	4	10	7	9	1.1
VS 14	14	23	4	10	10	9	1.4
VS 18	17.5	23	4	10	10	9	1.8
VS 20	20	23	4	10	10	9	2.2
VS 25	25	34	4	10	20	9	3.8
VS 26	25	31	8	16	11	13	8
VS 32	32	37.5	8	18	14.5	13	9.4
VS 42	42	46	8	18	22	13	18.5
VS 52	52	49	8	18	27	13	24.6
VS 62	62	55	8	21	31	13	50
VS 88	88	87.5	12	25	48.5	20	175

The values represent the average characteristics of our products.
 (1) f = Deflection of the suction pad.

Granular surfaces

For handling objects with a granular or textured gripping surface, use VS suction pads with the VSBM foam strip option (see page 2/14).

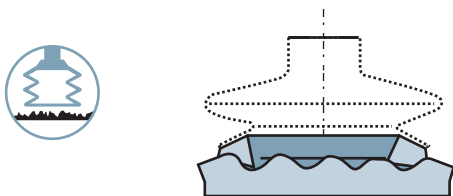

Types of assembly

Factory-crimped fitting:

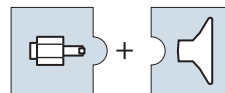

Hollow shaft fitting:

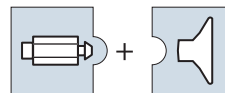

Removable fitting: (adapter and hollow screw)

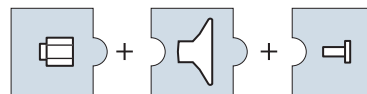

Assembly diagrams

COVAL suction pads can be assembled in a wide variety of configurations. see pages 2/15 to 2/17.

Accessories

To optimize the use of your suction pads, Coval offers a comprehensive range of accessories (feelers, spring extensions, and feeder systems, etc.), see chapters 5 and 13.



Branch-specific applications

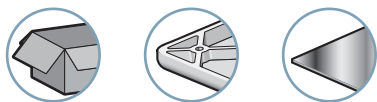

Presentation

The VPO series of suction pads is used for the handling oblong products, such as pens, tubes and bottles, and flat or cylindrical objects.





2

Types of use



Materials

NBR Nitrile
SI Silicone
STN Siton®

					L (mm)	l (mm)	B2 (mm)	Ø d (mm)	H (mm)	f (mm)	C (mm)	C1 (mm)	C2 (mm)	Ø D (mm)	G (mm)	E (mm)	j (mm)	NBR	SI	STN
VPO 24	0.004	0.315	1	4	2	3.5	0.7	6	0.5	5	-	3	1	M3	5	-	-	■	■	■
VPO 357	0.019	0.75	3	7	3.5	3.5	1	6	0.8	5	-	3	1	M3	5	-	-	■	■	■
VPO 515	0.036	2.33	4	15	5	7	1.2	12	0.7	10	8.5	5	2	M5	8	-	-	■	■	■
VPO 618	0.058	3.38	4	18	6	7	1.5	12	0.8	10	8.5	5	2	M5	8	-	-	■	■	■
VPO 824	0.138	6.0	8	24	8	4.3	1.5	12	1	13	9	8	3.5	1/8G	14	4	-	■	■	■
VPO 1030	0.280	9.15	8	30	10	4.3	2.5	12	1.5	13	9	8	3.5	1/8G	14	4	-	■	■	■
VPO 1545	0.980	21.15	10	45	15	6	3	21	2	15	12	10	3.5	1/4G	17	4	-	■	■	■
VPO 2060	2.30	37.57	20	60	20	5	4	21	2.5	15	12	10	3.5	1/4G	17	4	-	■	■	■
VPO 2575	4.70	58.7	30	75	25	7	4	21	2.8	15	12	10	3.5	1/4G	17	4	-	■	■	■
VPO 3090	8.50	84.5	35	90	30	5	4	21	3.5	15	12	10	3.5	1/4G	17	4	-	■	■	■

(1) Actual force of the suction pad with a 90% vacuum and a safety factor of 2 included.

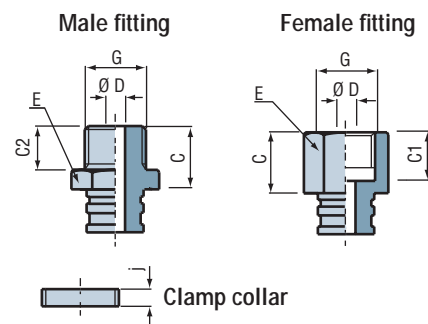
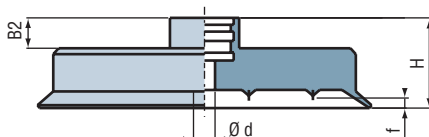
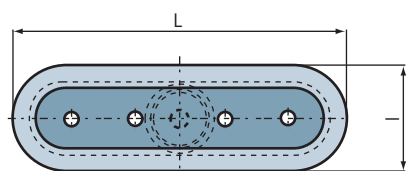

Adaptable fittings

	Connection	Male fitting	Female fitting	Collar
VPO 24, 357	M3	IM 3 VPO 24	-	-
VPO 515, 618	M5	IM 5 VPO 515	IF 5 VPO 515	-
VPO 824, 1030	1/8 G	IM 18 VPO 824	IF 18 VPO 824	VPO COV18
VPO 1545... 3090	1/4 G	IM 14 VPO 1545	IF 14 VPO 1545	VPO COV14

Collar must be used from 8 x 24 upwards to prevent unintentional rotation when in use.

Fitting: M = male
F = female

Accessories

Anti-rotation spring system, see page 5/4.

For all orders, please specify: Model + Material + Fitting

1: Model	2: Material	3: Fitting
VPO Please refer to the table	NBR, SI or STN	IF Please refer to the table IM

E.g. VPO 618 NBR IF M5
(VPO series suction pad, model 618, in Nitrile, M5 female fitting)



Branch-specific applications



Types of use

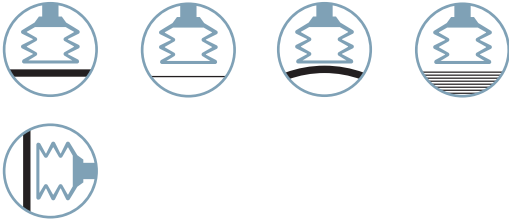

Presentation

The C series high-performance suction pad range has been designed to meet the requirements of the automotive sector. The improved characteristics of the C series range optimizes production tools in all branches of activity.

- A full range of shapes and diameters to meet every requirement.
- Non-slip cleats ensure optimum positioning of oily sheet metals.
- Textured suction pads for gripping thin sheets without deforming them.
- Ideal for automated applications.
- Specifically for use in the fields of stamping and welding.

Characteristics

- Extreme resistance to slipping.
- Gripping of thin metal sheets without deforming them, thanks to the central cleats.
- Elastomer and glass-fibre reinforced plastic design to avoid any risk of damaging costly equipment and to facilitate recycling.
- Double tightening: 2 wrenches of 22 mm and 1 hex key of 6 mm or 8 mm.
- Air-tight fittings using: - O-rings on 3/8G male cylindrical suction pads 32 square suction pads,- sealing on all oblong 3/8 male suction pads.

Materials

Suction pads:

NBR Nitrile 55 shores (high resistance to oils), grey color.

Fitting:

PA Polyamide PA 6.6 ensuring reduced weight (3/8G Male or Female fitting).

O-ring:

NBR Nitrile blue or black.

Square coupling:

Aluminum

Other fittings available on request.



3/8G female fitting



3/8G male fitting



32 square coupling

Accessories

To optimize use of your suction pads, Coval offers a comprehensive range of accessories (3/8G extensions, feeders and special couplings for 100% air-tight vacuum networks,) see chapters 5 and 13.

For all orders, please specify:

Model + Dimensions + Fitting

1: Model	2: Dimensions	3: Fitting
CFC	85 please refer to the codes in the tables of characteristics	M38G 3/8G male fitting
CBC		F38G 3/8G female fitting
COFC		C32 square coupling
COBC		

E.g. CBC 85 M38G





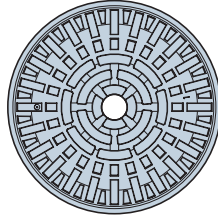

(Round C series suction pad with 1.5 bellows Ø 85, 3/8G male fitting)







2



CFC flat suction pad

	Ø at rest (mm)	Ø gripping (mm)	 (cm ³)	 (N) ⁽¹⁾	 (N) ⁽¹⁾	 R _{min} (mm)	 R _{min} (mm)	Ø bore (mm)	tightening (mm)
CFC 35	37	38.5	2.46	50	50	58	50	6.3	w 22 + hk 6 ⁽³⁾
CFC 50	51	54	8.37	100	100	66	52	6.3	w 22 + hk 6 ⁽³⁾
CFC 75	76	80	25.03	200	170	100	58	6.3	w 22 + hk 6 ⁽³⁾
CFC 100	101	105.7	57.61	350	270	120	90	6.3	w 22 + hk 6 ⁽³⁾
CFC 125	127	132	119.7	550	480	160	115	6.3	w 22 + hk 8 ⁽³⁾

	H1 (mm)	D (mm)	E (mm)	f ⁽²⁾ (mm)	 (g)		
					 F 3/8G	 M 3/8G	 C32
CFC 35	25	10	12.6	3	14	18	36.2
CFC 50	30	10	12.6	5.5	25	29	47.2
CFC 75	33	10	12.6	8	40	45	62.2
CFC 100	38	10	12.6	10	67	72	89.2
CFC 125	44	10	12.6	14	119	124	141.2

(1) Force measured at 65% on dry, smooth, flat sheet metal without safety factor.

(2) f: deflection of the suction pad.

(3) w = wrench, hk = hex key

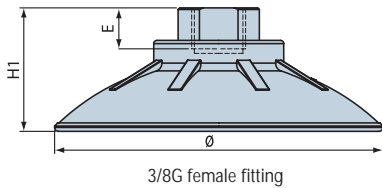

3/8G female fitting

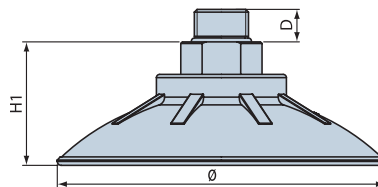



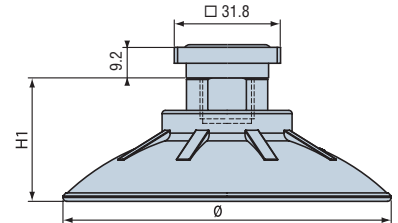



3/8G male fitting

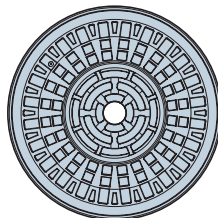





32 square coupling

CBC suction pad with 1.5 bellows



	Ø at rest (mm)	Ø gripping (mm)	 (cm ³)	 (N) ⁽¹⁾	 (N) ⁽¹⁾	 R _{min} (mm)	 R _{min} (mm)	Ø bore (mm)	tightening (mm)
CBC 30 ⁽³⁾	32	34	5	40	40	30	32	6.3	w 22 + hk 6 ⁽³⁾
CBC 45	47	48.7	11.47	70	90	36	45	6.3	w 22 + hk 6 ⁽³⁾
CBC 60	62	64.5	25.31	140	130	44	62	6.3	w 22 + hk 6 ⁽³⁾
CBC 85	85	88	66.54	230	240	65	115	6.3	w 22 + hk 6 ⁽³⁾
CBC 115	115	119	141.47	420	390	84	140	6.3	w 22 + hk 8 ⁽³⁾

	H1 (mm)	D (mm)	E (mm)	f ⁽²⁾ (mm)	 (g)		
					 F 3/8G	 M 3/8G	 C32
CBC 30 ⁽³⁾	31	10	12.6	8	14	19	36.2
CBC 45	36	10	12.6	11	22	26	44.2
CBC 60	41	10	12.6	14	32	37	54.2
CBC 85	51	10	12.6	22	64	69	86.2
CBC 115	53	10	12.6	24	103	107	125.2

(1) Force measured at 65% on dry, smooth, flat sheet metal without safety factor.

(2) f: deflection of the suction pad.

(3) w = wrench, hk = hex key

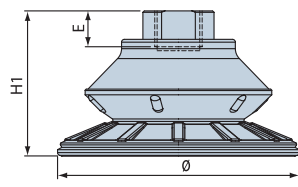

3/8G female fitting

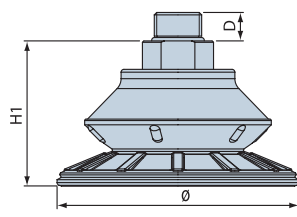

3/8G male fitting

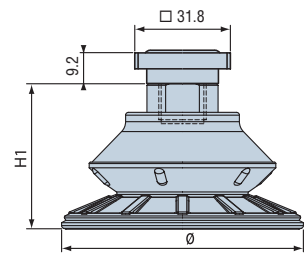

32 square coupling

3) A specific model of the CBC 30 is available with M 3/8G fitting and 9.5mm diameter bore.

Order reference: CBC 30 M38G SP624 (black O-ring).





COFC flat oblong suction pad

	Dim. at rest (l x L mm)	Dim. gripping (l x L mm)	Volume (cm ³)	Force (N) ⁽¹⁾	Force (N) ⁽¹⁾	R _{min} (mm)	R _{min} (mm)	Ø bore (mm)	tightening (mm)
COFC 2565	25x65	26.8x67	3.78	70	70	25	25	6	hex key 6
COFC 3080	30x80	31.5x82	6.08	110	90	40	32	6	hex key 6
COFC 4080	40x80	42x82	11.03	140	120	60	40	6	hex key 6
COFC 50100	50x100	52.5x102.5	22.25	230	240	70	50	6	hex key 6

2

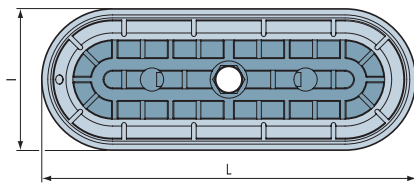

	H1 (mm)	H2 (mm)	D (mm)	E (mm)	f ⁽²⁾ (mm)	Weight (g)		
						F 3/8G	M 3/8G	C32
COFC 2565	31.5	12.5	8	10	3	24	17	35
COFC 3080	32	13	8	10	3	29	22	40
COFC 4080	34	15	8	10	4.5	30	23	41
COFC 50100	35	16	8	10	6	43	36	54

(1) Force measured at 65% on dry, smooth, flat sheet metal without safety factor.
 (2) f: deflection of the suction pad.

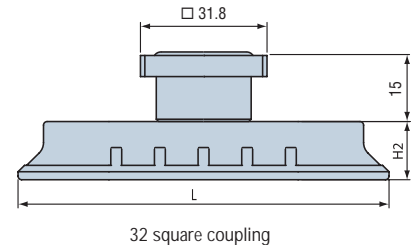
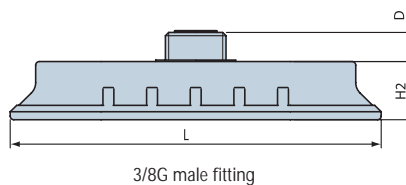
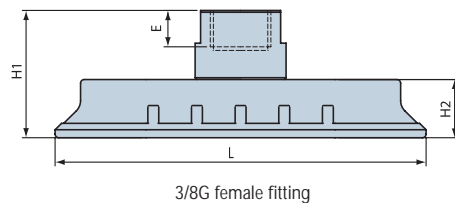

COBC oblong suction pad with 1.5 bellows

	Dim. at rest (l x L mm)	Dim. gripping (l x L mm)	Volume (cm ³)	Force (N) ⁽¹⁾	Force (N) ⁽¹⁾	R _{min} (mm)	R _{min} (mm)	Ø bore (mm)	tightening (mm)
COBC 3065	31x65	32.3x67	9.98	60	60	25	30	6	hex key 6
COBC 4080	40x80	41.5x82	19.44	110	120	38	37	6	hex key 6
COBC 55110	55x110	57x112.5	49.25	170	190	58	57	6	hex key 6
COBC 70140	70x140	72x143	93.57	300	300	72	68	6	hex key 6

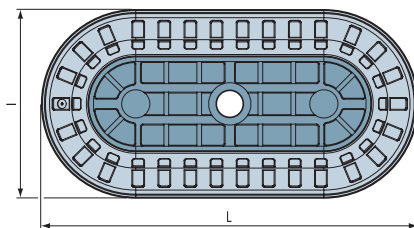

	H1 (mm)	H2 (mm)	D (mm)	E (mm)	f ⁽²⁾ (mm)	Weight (g)		
						F 3/8G	M 3/8G	C32
COBC 3065	39	20	8	10	7	31	25	43
COBC 4080	41	22	8	10	9	37	31	49
COBC 55110	48	29	8	10	13	68	62	80
COBC 70140	49	30	8	10	16	103	97	115

(1) Force measured at 65% on dry, smooth, flat sheet metal without safety factor.
 (2) f: deflection of the suction pad.

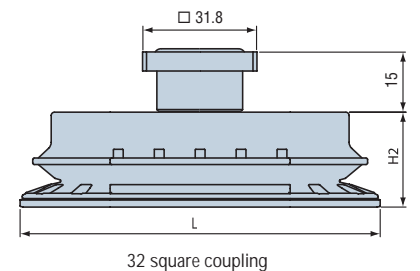
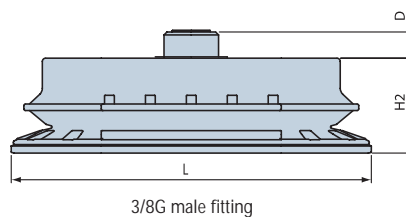
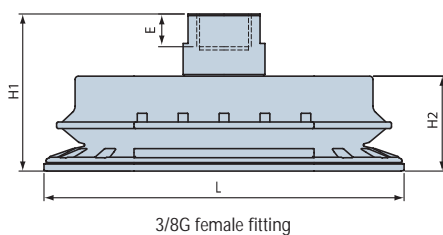



Branch-specific applications



2

Use

The foam ring is designed for gripping products with an uneven or ridged surface, e.g.

- Sawn wood, metal sheets, flat surfaces with bumps or hollows.
- All granular surfaces to which suction pads cannot adhere correctly and therefore cannot be air-tight.

Materials

NBR Nitrile
Si Silicone

Operating characteristics of the materials

■ Nitrile (NBR - Black)

5 or 10mm thick, depending on the diameters of the suction pads.
Good resistance to oil.

The nitrile foam strip can only be bonded to nitrile suction pads.

■ Silicone (SI - White)

2 or 5 mm thick, depending on the diameters of the suction pads.

Heat-resistant up to 320 °F, does not leave marks on products handled.

Do not use the silicone foam strip for gripping products before painting or lacquering.

The silicone foam strip can only be bonded onto silicone suction pads (bonding is guaranteed if it is performed in the factory).

■ Mounting

The foam rings are mounted by bonding. In all cases, this should be performed in our factory as we have the adhesives adapted to the materials.

It is essential that bonding of silicone should be performed in the COVAL factory.

Ø (mm)	NBR				SI			
	Ref.	ØA (mm)	ØB (mm)	C (mm)	Ref.	ØA (mm)	ØB (mm)	C (mm)
20	-	-	-	-	VSBM 20 SI	20	10	2
25	-	-	-	-	VSBM 25 SI	25	13	2
32 - 33	VSBM 32 NBR	32	22	5	VSBM 32 SI	32	19	2
42 - 43	VSBM 42 NBR	42	28	5	VSBM 42 SI	42	20	5
52 - 53	VSBM 53 NBR	53	33	10	VSBM 53 SI	53	33	5
62- 63	VSBM 62 NBR	62	42	10	VSBM 62 SI	62	42	5
78	VSBM 78 NBR	78	58	10	VSBM 78 SI	78	54	5
88	VSBM 88 NBR	88	68	10	VSBM 88 SI	88	64	5

Note: Suction pads with bellows are preferable when foam rings are required, as the slope of the lips is better suited to this type of grip. Please consult us for other models based on quantities.

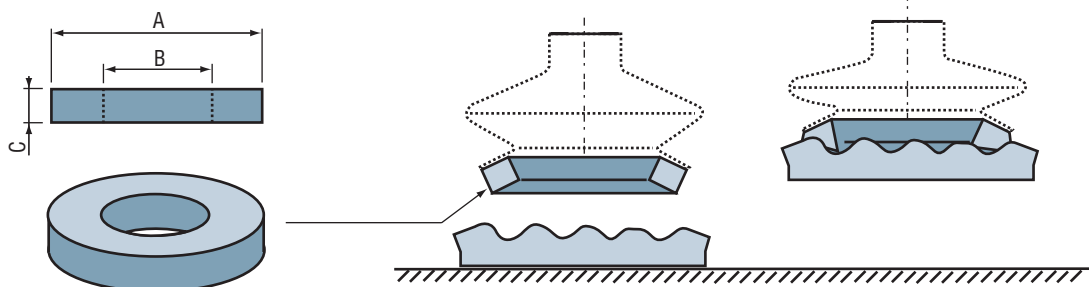

Group 1

Hollow shaft fittings

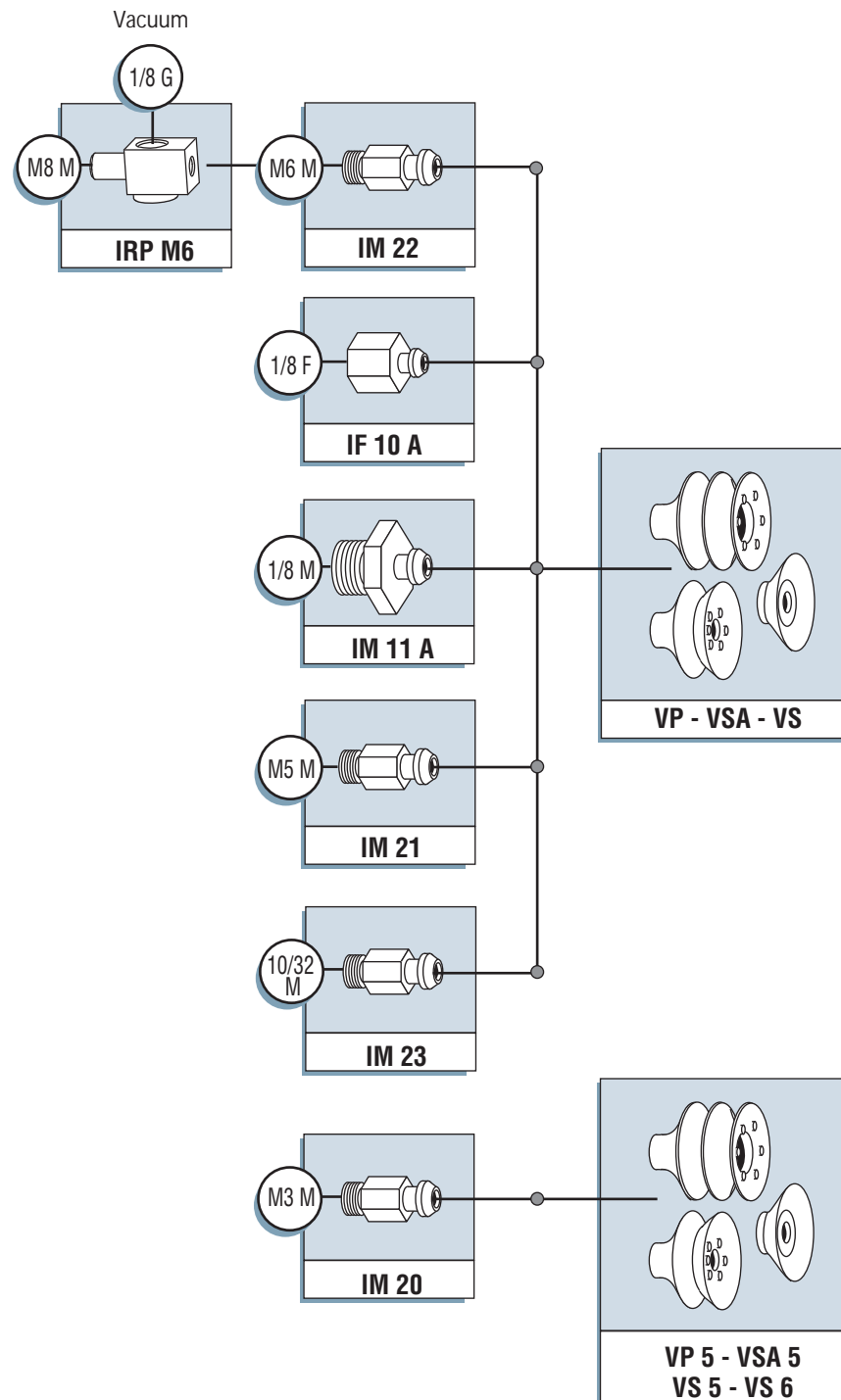

Note: Nozzle fittings for random gripping are available for these suction pads (see pages 5/6 and 5/7).

Fittings dimensions:
see pages 2/22 and 2/23.

Group 2

Factory-cripped fittings

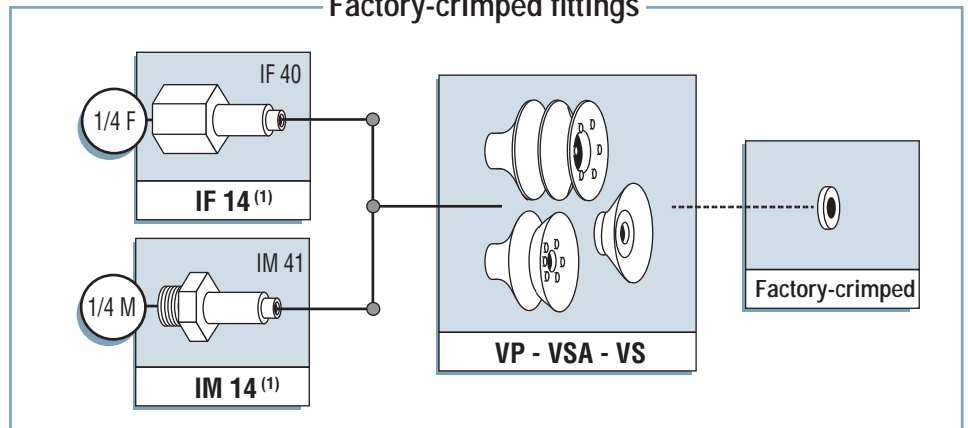

Hollow shaft fittings

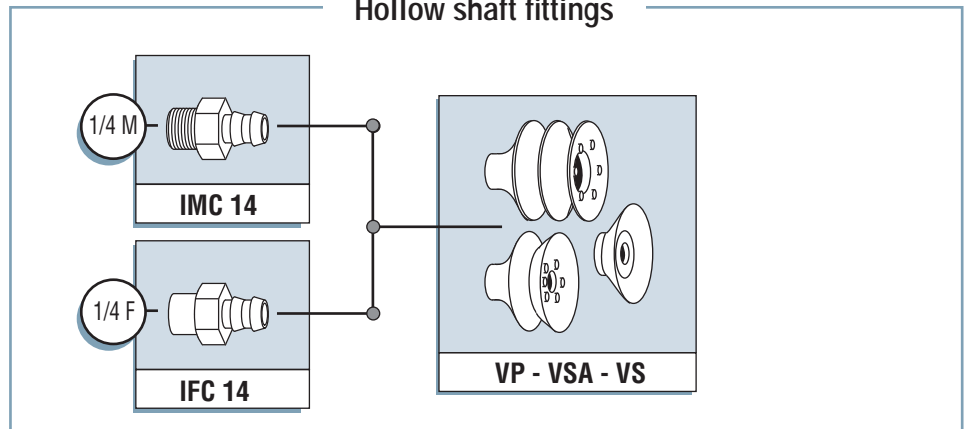

Removable fittings

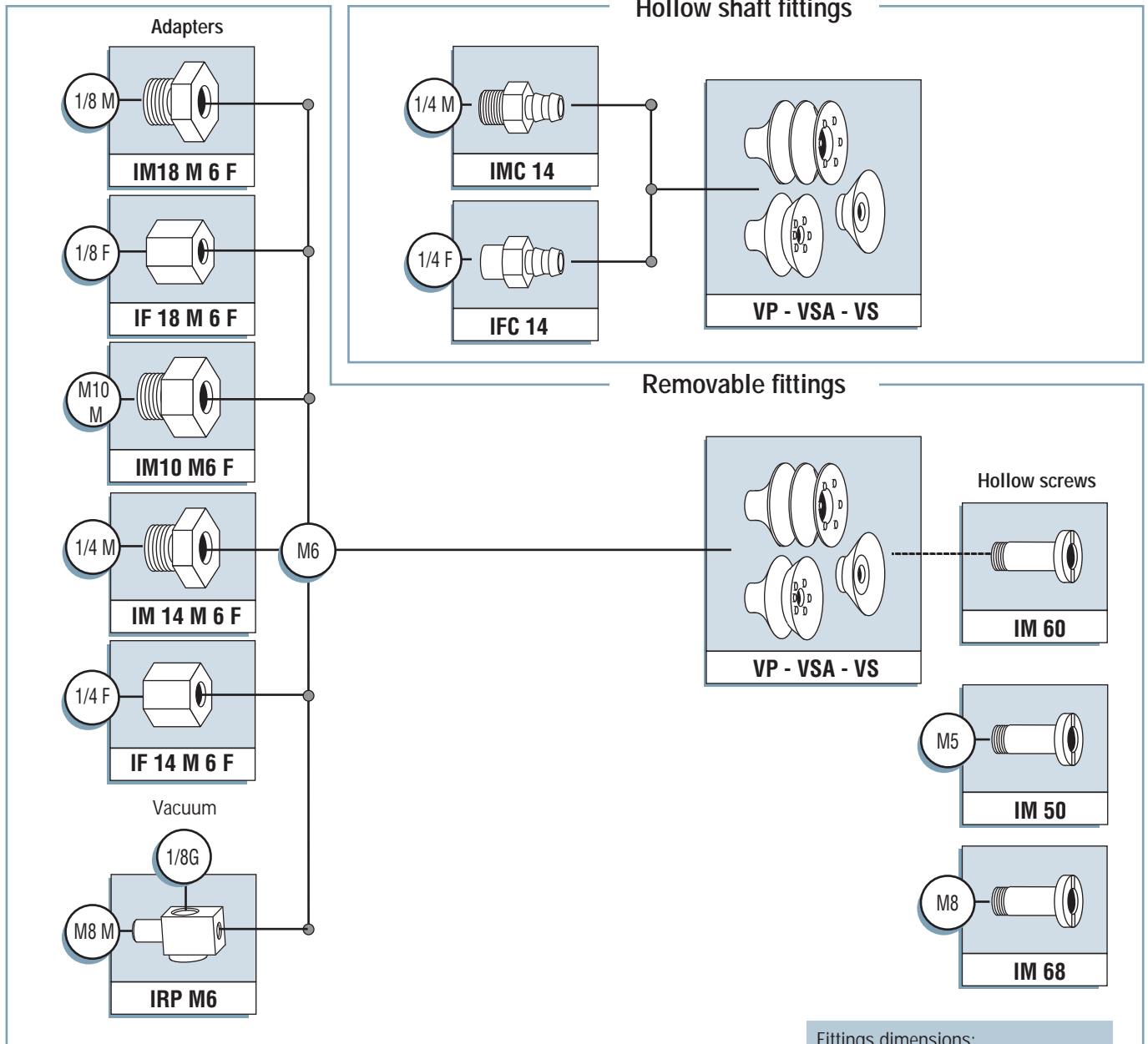

Fittings dimensions:
see pages 2/22 and 2/23.

(1) Reference = fitting crimped onto the suction pad by COVAL.

Group 3

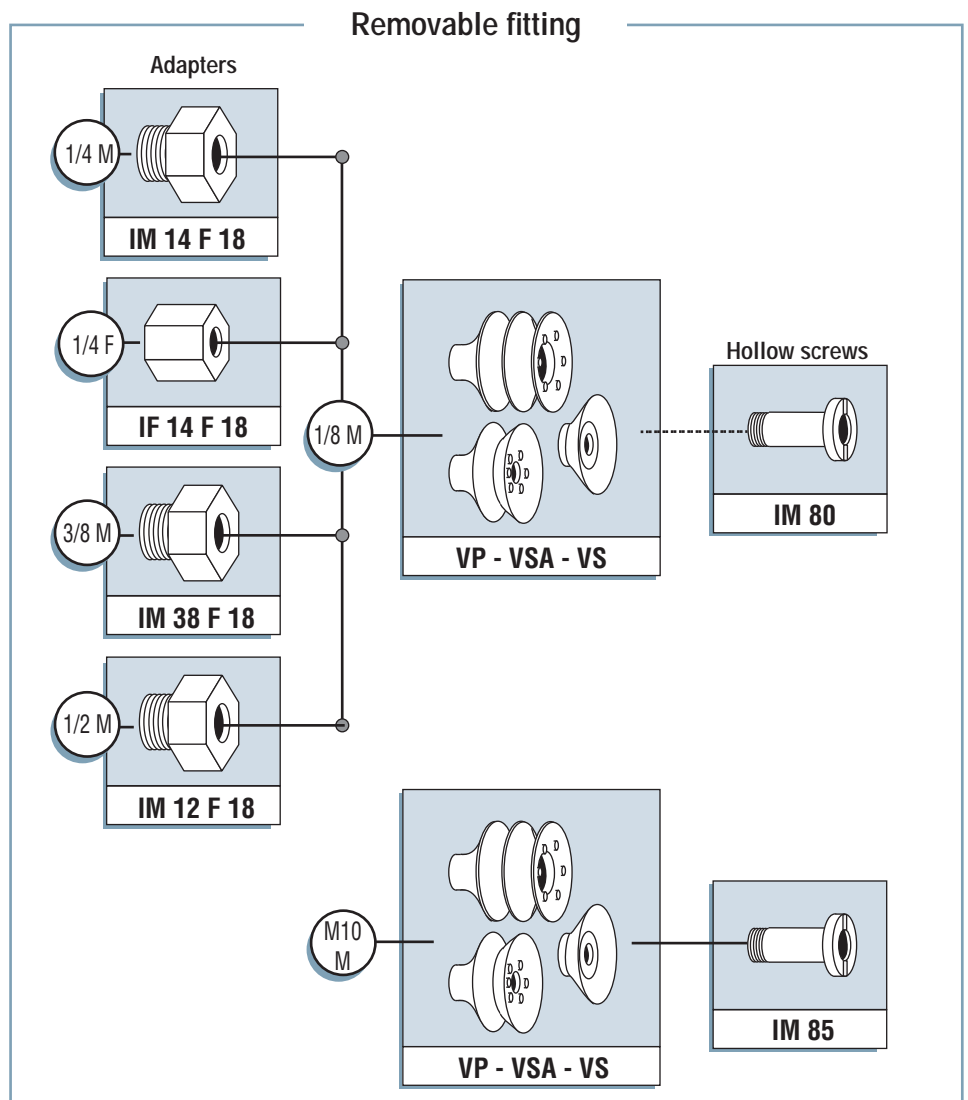
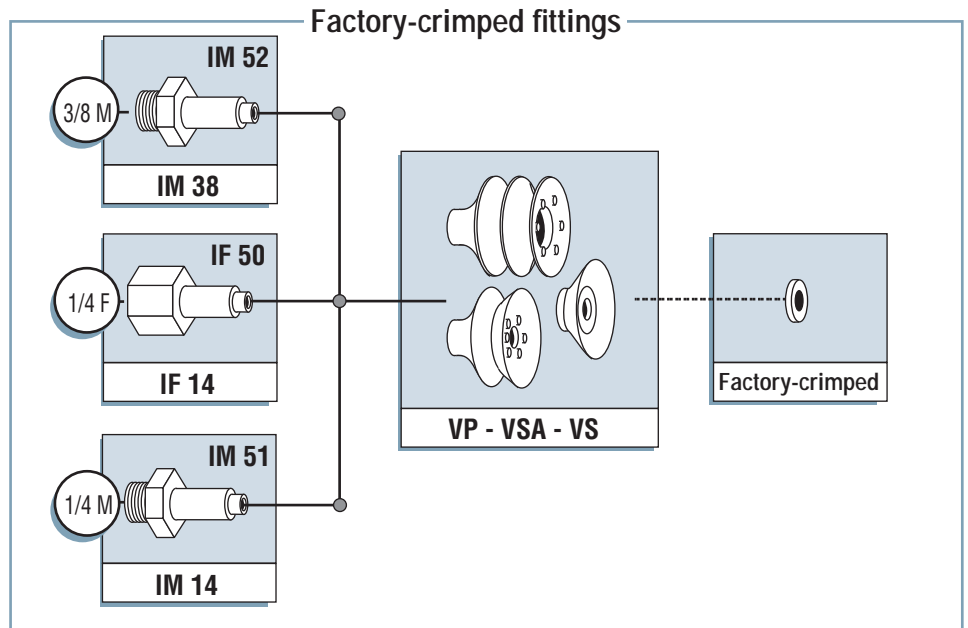

Fittings dimensions:
see pages 2/22 and 2/23.

Hollow shaft fittings

2

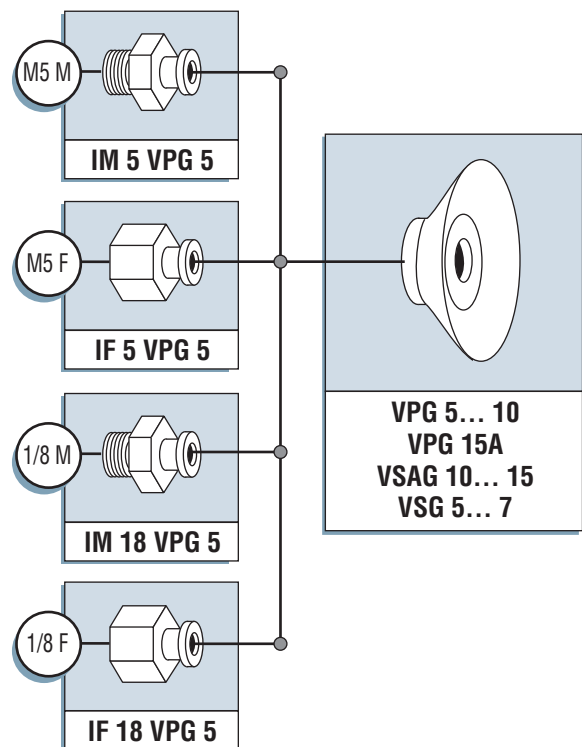
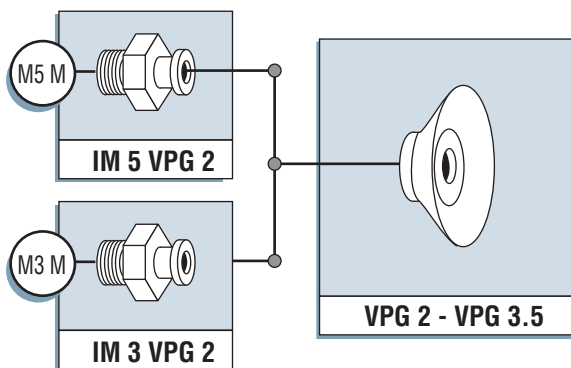
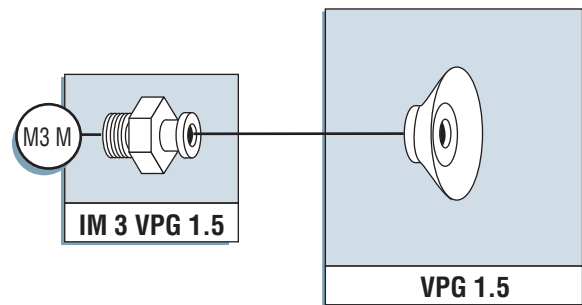
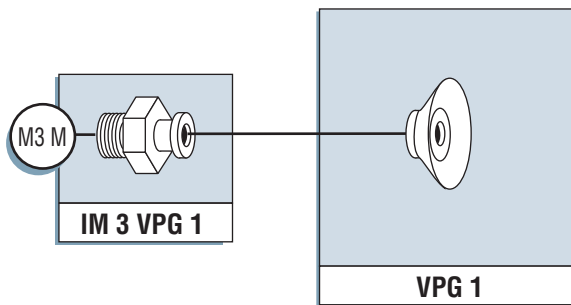

Fittings dimensions:
see pages 2/22 and 2/23.

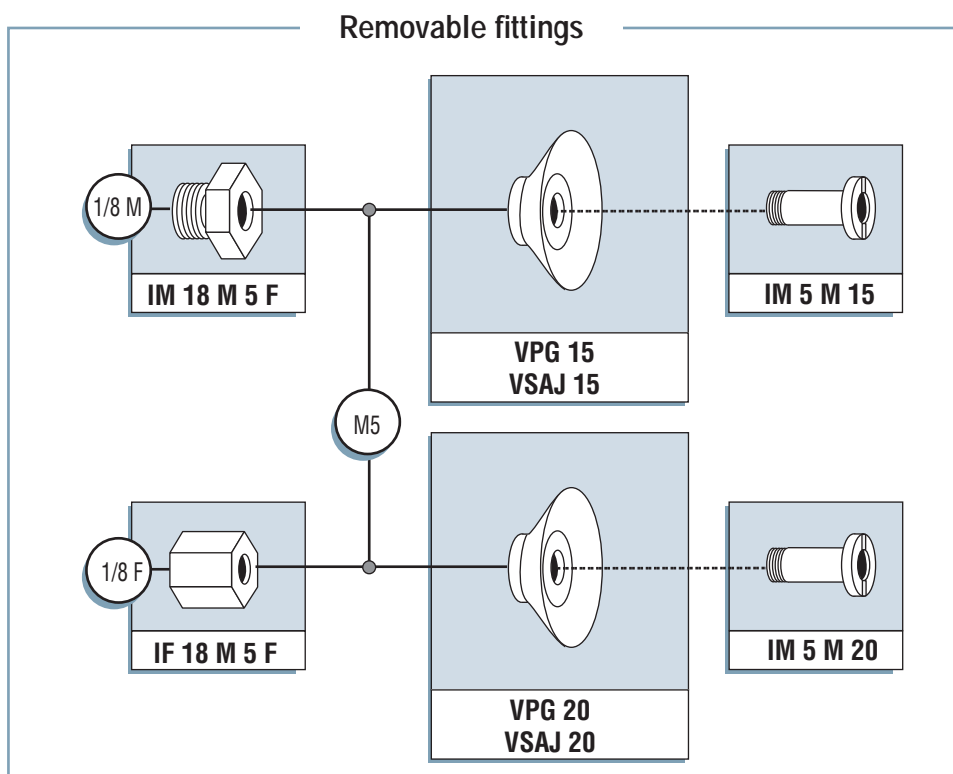
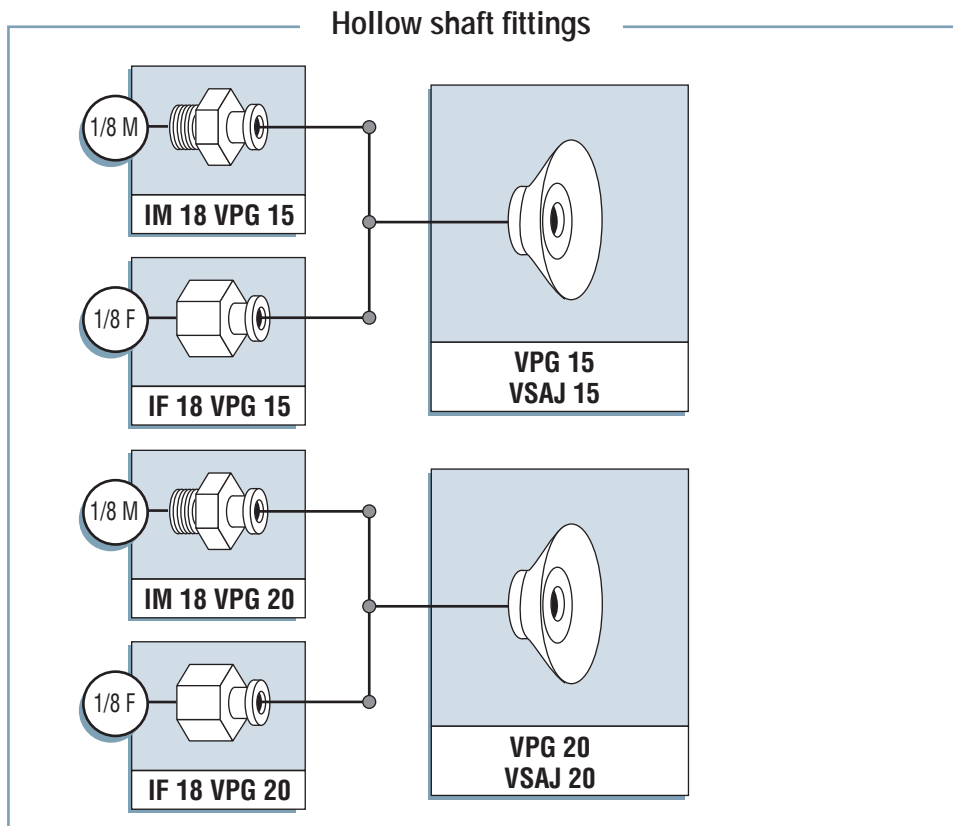

Fittings dimensions:
see pages 2/22 and 2/23.

assembly diagrams

VPG 25... 50, VPG 20B VSAG 20B... 50 VSAJ 30

2

Hollow shaft fittings

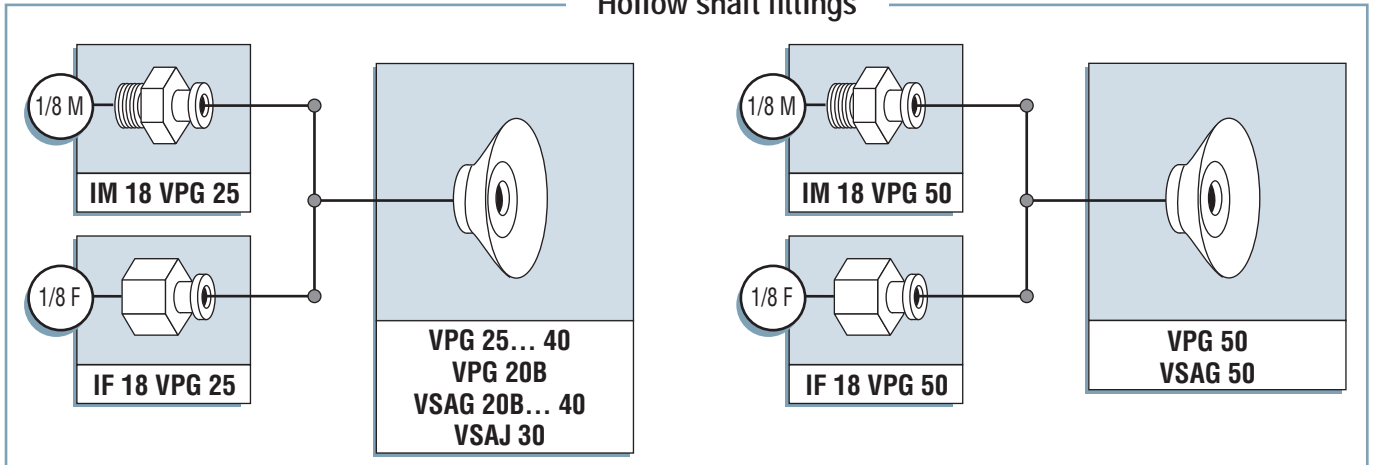

Removable fittings

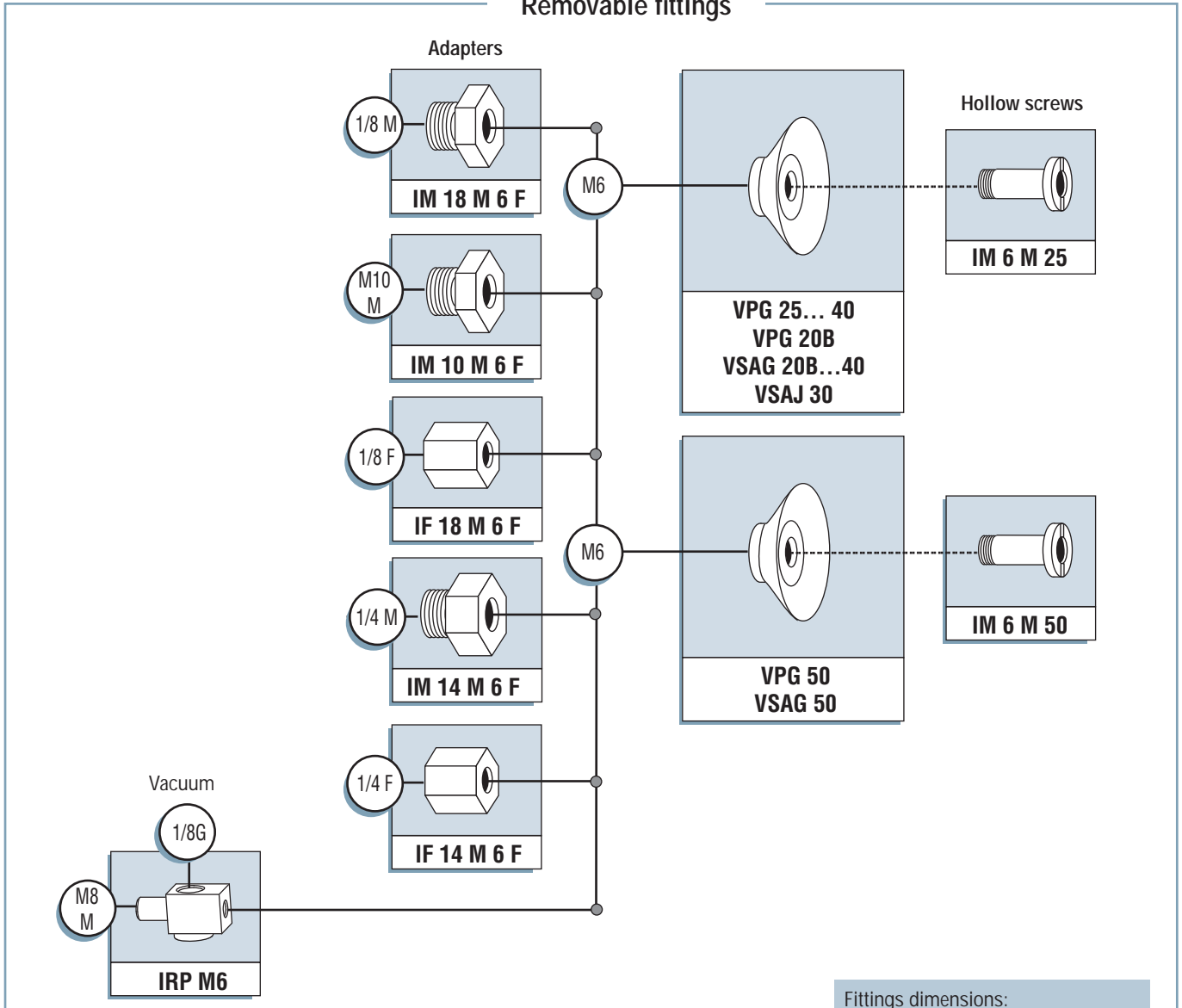

Fittings dimensions:
see pages 2/22 and 2/23.

Removable fittings

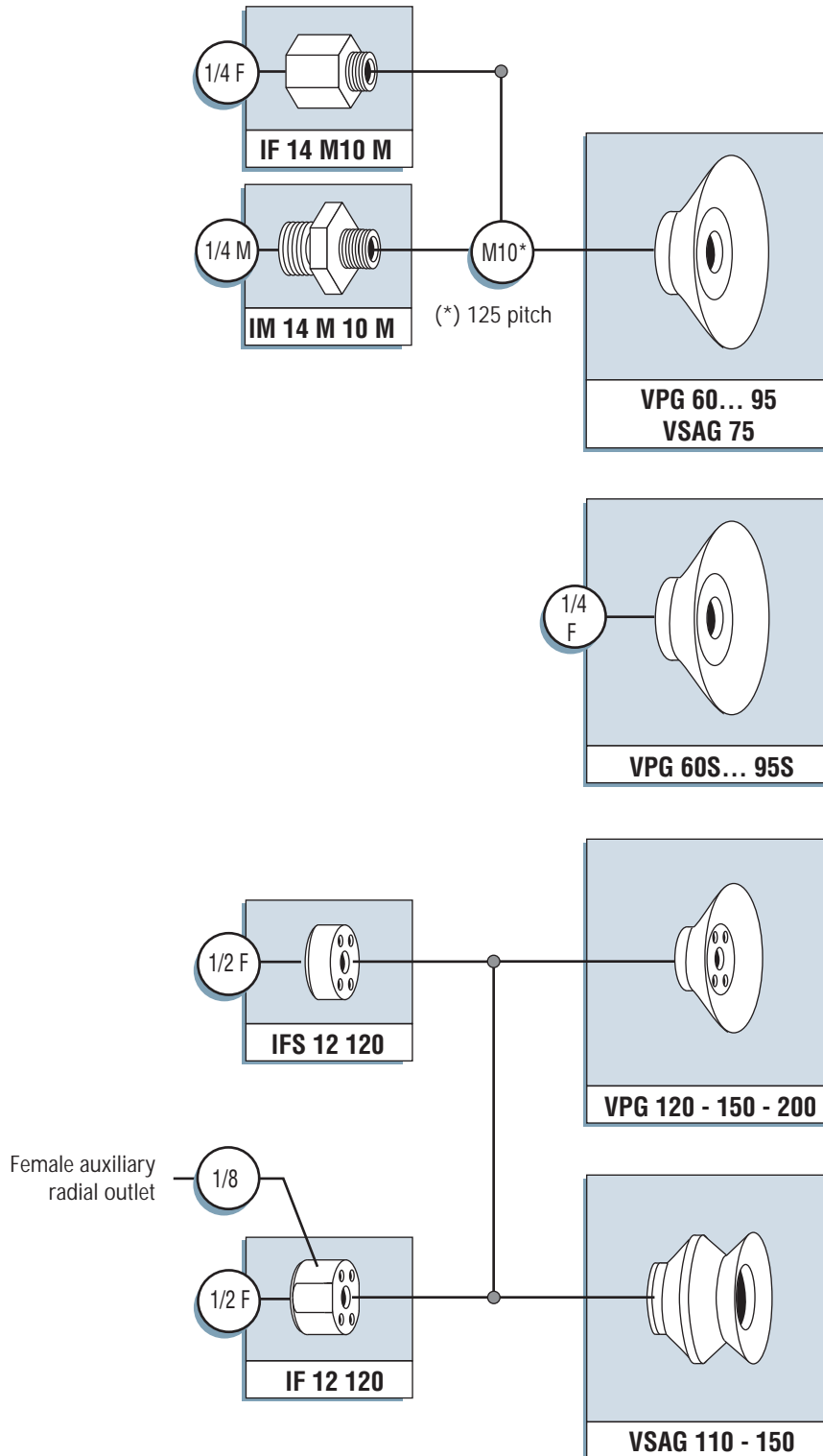

Fittings dimensions:
see pages 2/22 and 2/23.

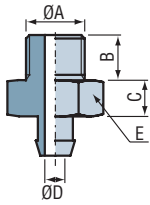

Hollow shaft fittings

	ØA (mm)	B (mm)	C (mm)	ØD (mm)	E (mm)
IM 3 VPG 1	M3	3	2	0.4	5
IM 3 VPG 1.5	M3	3	2	0.7	5
IM 5 VPG 2	M5	4.5	3.5	1	7
IM 5 VPG 5	M5	4.5	3.5	2.5	7
IM 11 A ⁽¹⁾	1/8G	7.5	6	3.5	14
IMC 14	1/4G	10	8	7	17
IM 18 VPG 5	1/8G	8	5	2.2	14
IM 18 VPG 15	1/8G	8	5	2.2	14
IM 18 VPG 20	1/8G	8	5	3	14
IM 18 VPG 25	1/8G	8	5	4	14
IM 18 VPG 50	1/8G	8	5	4	14
IM 20	M3	3	2	1.4	5
IM 21 ⁽²⁾⁽³⁾	M5	4.5	5	2.5	7
IM 22	M6	5	5	3.5	7
IM 23	10-32	4.5	5	2.5	7
IM 24	M5	4.5	2.5	2.5	10
IM 3 VP 42	M3	3	2	1	5

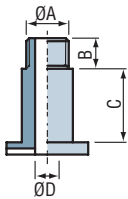

Hollow screws

	ØA (mm)	B (mm)	C (mm)	ØD (mm)
IM 5 M 15	M5	5	2	2.5
IM 5 M 20	M5	5	4	2.5
IM 6 M 25	M6	6	6	3.5
IM 6 M 50	M6	6	6	3.5
IM 50	M5	5	11	2.8
IM 60 ⁽³⁾	M6	7	11	3.5
IM 68	M8	8	11	5.2
IM 80	1/8G	8	18	6
IM 85	M10x150	8	18	6

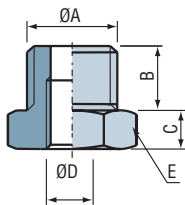

Adapters for hollow screws

	ØA (mm)	B (mm)	C (mm)	ØD (mm)	E (mm)
IM 10 M 6 F ⁽¹⁾	M10	7	3.5	M6	13
IM 12 F 18	1/2G	14	6	1/8 G	22
IM 14 M 6 F ⁽¹⁾	1/4G	8	5	M6	17
IM 14 F 18	1/4G	8	5	1/8 G	17
IM 18 M 5 F	1/8G	6	4.5	M5	13
IM 18 M 6 F ⁽¹⁾	1/8G	6	4.5	M6	13
IM 38 F 18	3/8G	9	5	1/8 G	19

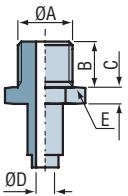

Riveted (factory-crimped)

	ØA (mm)	B (mm)	C (mm)	ØD (mm)	ØE (mm)
IM 41 ⁽³⁾	1/4G	11	4	4.4	17
IM 51	1/4G	11	6	8	21
IM 52	3/8G	11	6	8	21

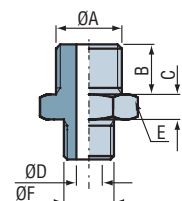

Screwed

	ØA (mm)	B (mm)	C (mm)	ØD (mm)	E (mm)	ØF (mm)
IM 14 M 10 M	1/4G	10	5	5	17	M10x125

(1) Available in NPT version

(2) Possibility of integrating a jet of calibrated diameter to reduce leaks when a multi-suction pad unit is being used (Ø 0.45mm stocked as standard)

(3) Available in stainless steel.

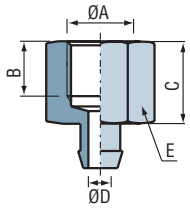

Hollow shaft fittings

	ØA	B	C	ØD	E
IF 5 VPG 5	M5	6	9	2.2	14
IF 10 A ⁽¹⁾	1/8G	8	12	3.5	14
IFC 14	1/4G	12	15	6.9	8
IF 18 VPG 5	1/8G	9	15	2.2	14
IF 18 VPG 15	1/8G	9	15	2.5	14
IF 18 VPG 20	1/8G	9	15	3	14
IF 18 VPG 25	1/8G	9	15	4	14
IF 18 VPG 50	1/8G	9	15	4	14

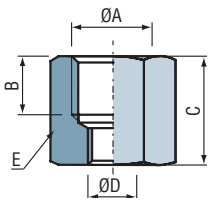

Adapters for hollow screws

	ØA (mm)	B (mm)	C (mm)	ØD (mm)	E (mm)
IF 14 M 6 F ⁽¹⁾	1/4G	11	16	M6	17
IF 14 F 18	1/4G	9	19	1/8G	17
IF 18 M 5 F	1/8G	7.5	13	M5	13
IF 18 M 6 F ⁽¹⁾	1/8G	7.5	13	M6	13

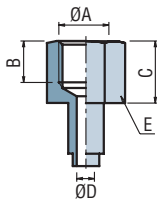

Riveted (factory-crimped)

	ØA (mm)	B (mm)	C (mm)	ØD (mm)	E (mm)
IF 40 ⁽³⁾	1/4G	10	15	4.4	17
IF 50	1/4G	10	15	8	21

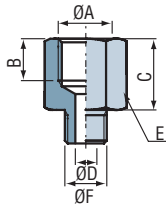

Screwed

	ØA (mm)	B (mm)	C (mm)	ØD (mm)	E (mm)	ØF (mm)
IF 14 M 10 M	1/4G	10	17	5	17	M10x125

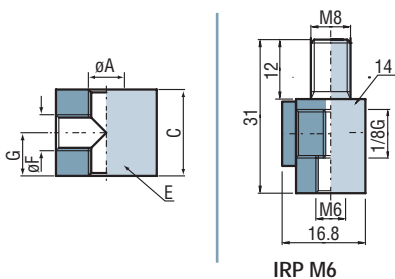

With radial outlet

	ØA (mm)	B (mm)	C (mm)	ØD (mm)	E (mm)	ØF (mm)	G (mm)
IR M5	M5	-	12	-	14X8	M5	6
IRP M6	See diagram						

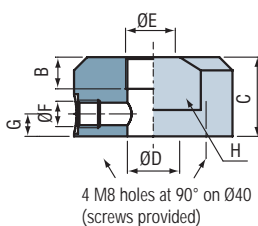

For VPG 120 to 200 and VSAG 110 and 150 suction pads

	ØA	B	C	ØD	E	ØF	G	H
IF 12 120 ⁽²⁾	1/2G	24	30	Ø19	Ø60	1/8G	8.7	48
IFS 12 120 ⁽²⁾	1/2G	13	13	-	Ø65	-	-	-

(1) Available in NPT version.
 (2) Fitting with 4 M8 holes for VPG 120 to 200 and VSAG 110 and 150 suction pads.
 (3) Available in stainless steel.

Special purpose suction pads

Thanks to its technological prowess and collaboration with its customers in different branches of activity, COVAL supplies a varied range of special purpose suction pads.

E.g. handling eggs, CDs, bottles, paper, cakes, sheet metal at high speed, etc.

MVS

- Suction pads with 1.5 - 2.5 and 3.5 bellows
- 4 models
- Silicone: food compatibility



P_{3/2}

- Used to grip delicate objects. Very flexible lip (opening bags, gripping tins and flexible aluminum or plastic bottles, etc.).
- High throughput rate
- Gripping of flexible products

VSD, VSE, VSP, VSB

- Suction pads with 2.5 to 5.5 bellows
- 13 models
- Food compatibility: silicone



P_{3/4}

- Range specially developed for gripping delicate objects such as cakes (buns, biscuits, etc.)
- Specific shapes and shore hardness depending on the applications
- Temperature resistance: - 40 °C to + 220 °C

VPA

- Flat suction pads
- 9 models
- Very flexible lip
- Materials: natural rubber and silicone (food compatibility)



P_{3/8}

- Range of suction pads with very flexible lip used to handle very flexible materials
- Very resistant to abrasion (for paper, cardboard)
- Very flexible gripping lip which molds to the shape of the object to be handled

VPR

- Flat suction pads
- 4 models
- Material: natural rubber



P_{3/9}

- The VPR range of suction pads is designed to meet the requirements of mailing applications.
- Envelope stuffing, film-wrapping, mailing (picking)
- Very resistant to abrasion

VSO

- Suction pads with 2.5 and 3.5 bellows
- 3 models
- Silicone: food compatibility



P_{3/3}

- Range specially designed to meet the constraints involved in handling eggs.
- Very flexible lip
- Different shapes of suction pad

VSBO

- Suction pads with 4.5 bellows
- 2 models
- High tensile force
- Highly flexible and long stroke



P_{3/6}

- Used to grip 75cl bottles and Magnums.
- Bottles gripped from the side, vertical and horizontal handling
- Suction pad with stainless steel reinforcement in the bellows

VPAG

- Curved suction pads
- 2 models
- Material: natural rubber

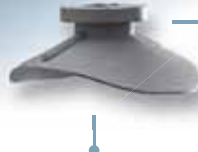

P_{3/9}

- Thanks to very flexible lips and a curved shape, the VPAG range is adapted to gripping flexible materials such as labels or sheets of paper - or textured objects
- Very resistant to abrasion

VPV, VSAV, VSV, VSAOV

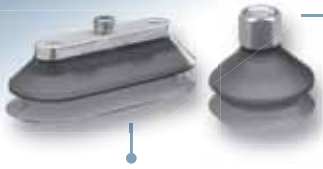

- Available in the following versions:
- Flat cylindrical, 1.5 and 2.5 bellows
 - Oblong, 1.5 bellows
 - Material: polyurethane

P 3/10

- Exceptionally resistant to abrasion
- For handling cardboard boxes or paper (very abrasive) in packaging machines with high throughput
- Excellent resistance to tearing

VPS



- Flat suction pads with extra-long shafts
- 4 models
- Materials: nitrile and silicone

P 3/12

- VPS suction pads are used to handle fragile objects
- Suction pads with extra-long shafts

VCD, VPCD



- Flat suction pads
- 5 models
- Material: silicone

P 3/13

- Specifically used to handle delicate objects at a high throughput rate (CDs, DVDs)
- Excellent resistance to high temperatures (silicone)

VPYR



- Flat suction pads with axial ball-joint system
- 4 models (Ø50 to 100mm)
- Materials: nitrile and silicone

P 3/14

- The range of ball-joint suction pads is recommended for gripping curved or rotating products which requires a lot of force and mechanical resistance

SPL



- "Heavy load" flat suction pads
- 5 models (Ø240 to 600mm)
- Materials: nitrile and silicone

P 3/15

- SPL suction pads are used to handle heavy loads such as metal sheets or glass panels. They have internal cleats allowing them to handle thin metal sheets without distorting them and for vertical handling (non-slip)

Acier



- Flat suction pads with a bonded foam seal
- 9 cylindrical models (Ø 150 to 580mm)
- 9 oblong models (175 x 115 to 705 x 385mm)

P 3/16

- For horizontal handling of heavy loads (thick metal sheets) or objects with an uneven surface such as concrete slabs or wood, etc.
- Wide choice of dimensions

VA



- Flat suction pads with a removable foam seal
- 5 cylindrical models (Ø 250 to 360mm)
- 5 oblong models (300 x 200 to 705 x 385mm)

P 3/17

- For horizontal handling of heavy loads (thick metal sheets) or objects with an uneven surface such as concrete slabs or wood, etc. (removable seal = easier maintenance)



Branch-specific applications

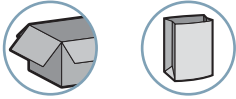

Types of use



3

Materials

- PVC** Polyvinyl chloride
- SIB** 35 shore white silicone (FDA)
- SIT5** Translucent silicone

Presentation

Used for all kinds of delicate gripping requiring a very flexible lip (opening bags, gripping tins and flexible aluminum or plastic bottles, etc.).

- High throughput rate
- Food compatibility
- Lip highly adaptable to the entire delicate surface to be handled.

	H (mm)	B (mm)	f ⁽¹⁾ (mm)	(cm ³)	(N) ⁽²⁾	PVC	SIB	SIT5	(g)
MVS 30 1.5 SIB	35	19.5	15.5	7	6.5		■		5.7
MVS 30 1.5 SIT5	35	19.5	15.5	7	-			■	5.7
MVS 30 2.5 SIB	46	19.5	20	11.2	9		■		6.5
MVS 30 3.5 B	46	8	-	-	-	■			-

(1) f = Deflection of the suction pad.

(2) Actual force of the suction pad with a 90% vacuum including a safety factor of 2.

MVS 30 1.5

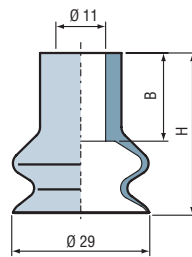

MVS 30 2.5

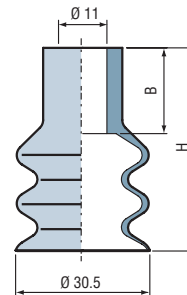

MVS 30 3.5

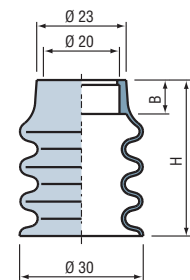

Fittings

- Fittings for MVS 30 1.5 SIB and MVS 30 2.5 SIB

- Male and female 1/4 G BSP. Add IM14 or IF14 at the end of the suction pad reference on your order.

- 1/4 G male IM51SP143
- 1/4 G female IF50SP143

IM51SP143

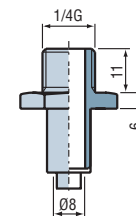

IF50SP143

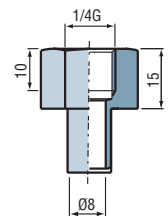

Accessories

To optimize use of your suction pads, Coval offers a comprehensive range of accessories (feelers, spring extensions, and feeder systems, etc.), see chapters 5 and 13.

For all orders, please specify: Model + Material + Fitting

1: Model		2: Material	3: Fitting
MVS	Please refer to the table	PVC	IM51SP143
		SIB	IF50SP143
		SIT5	

E.g. MVS 30 1.5 SIT5 IM14

(MVS 30 1.5 suction pad in translucent silicone with male 1/4 gas fitting)

Note: no fitting available for MVS 30 3.5



Branch-specific applications



Presentation

The VSO range of suction pads has been specially designed to meet the constraints involved in handling eggs.





- Very flexible lip
- Different shapes of suction pad
- Food standard silicone

Types of use



Materials

SI	35 shore red silicone	SIT6	60 shore translucent silicone
SIT3	35 shore translucent silicone		

	 (cm ³)	 (N) ⁽¹⁾	SI	SIT3	SIT6	 (g)
VSO 30 SI	40	1.5	■			17
VSO 33 SIT6	13	1.5			■	7.3
VSO 36 SIT3	34	1.5		■		16.3

(1) at 30% vacuum with a safety factor of 2 included.

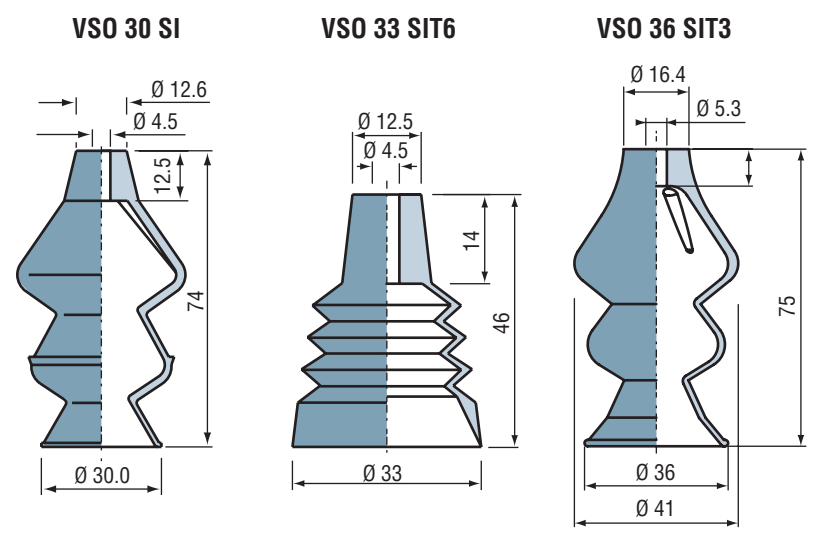

For all orders, please specify: Model + Material + Fitting

1: Model	2: Diameter	3: Material
VSO Please refer to the table	30 ... 36 Please refer to the table	SI Please refer to the table

E.g. VSO 30 SI (Diameter 30 VSO suction pad in red silicone)

VSD, VSE, VSP series

Suction pads for bakery applications



Branch-specific applications



Presentation

Suction pads specially developed for gripping delicate objects such as cakes (buns, biscuits, etc.) Specific shapes and shore hardness depending on the applications. Food standard translucent silicone means the suction pads can be used at temperatures between - 40 °F to + 428 °F.

Types of use



Materials

Si	Silicone	SIT5	50 shore translucent silicone
Si3	30 shore silicone	SIT6	60 shore translucent silicone
Si5	50 shore silicone	SIT7	70 shore translucent silicone
SIT3	30 shore translucent silicone		

Icon	dim. (mm)	height (mm)	f ⁽¹⁾ (mm)	maximum vacuum (%)	shore hardness	Fittings			
						M5M	1/4G M	1/8G F	1/8G M
	Ø 25	45	24	90	30				
	Ø 38	35	21	15	30				
	Ø 38	35	21	20	50				
	Ø 35	42	26	20	30				
	Ø 35	42	26	30	50				
	Ø 39	44	28	30	50				
	Ø 14	19	9	70	30 ⁽²⁾	IM21SP139		IF10ASP139	IM11ASP139
	Ø 14	19	9	90	60	IM21SP139		IF10ASP139	IM11ASP139
	22 x 58	35	8	20	50				
	22 x 58	35	8	30	70				
	27 x 47	50	26	15	30		IM14VSP3856		
	38 x 56	50	28	15	50		IM14VSP3856		
	23 x 76	44	14	15	50				

(1) f = Deflection of the suction pad / (2) Non-toxic red silicone.

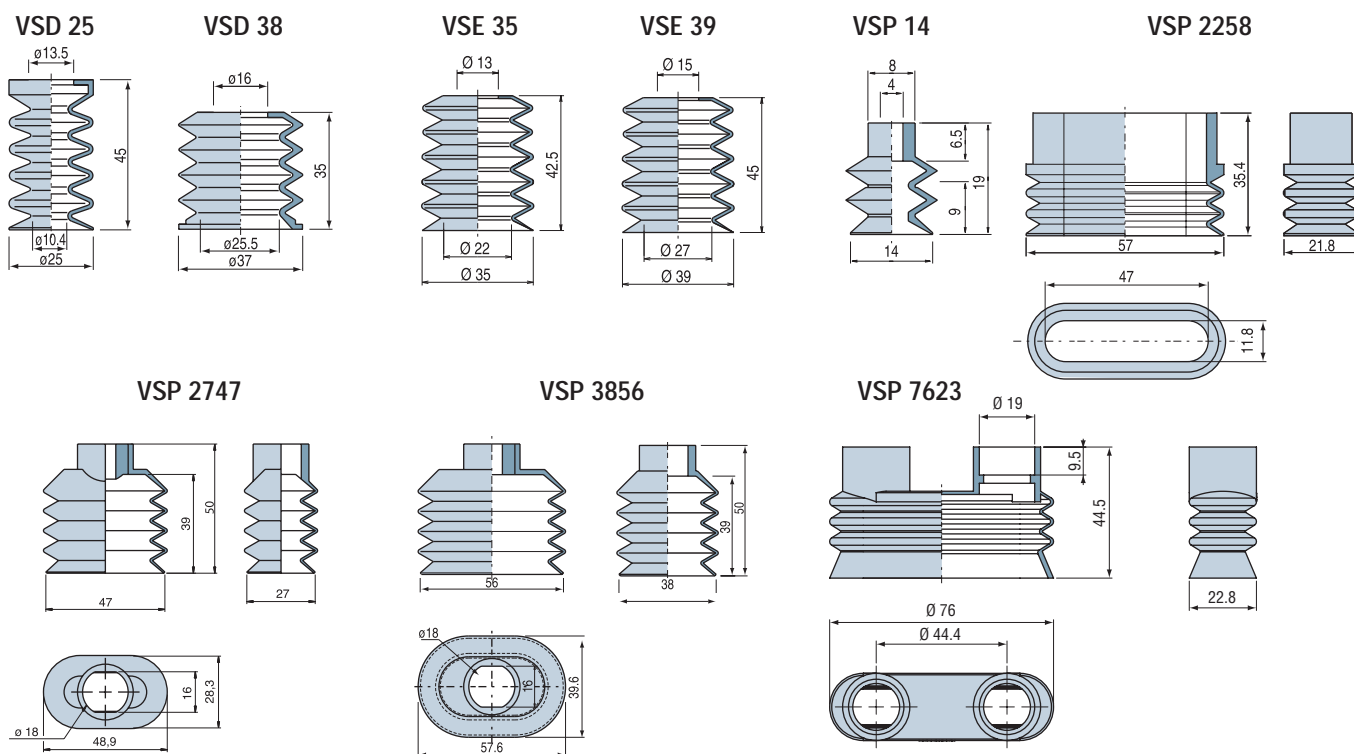

Accessories

To optimize use of your suction pads, Coval offers a comprehensive range of accessories (feelers, spring extensions, and feeder systems, etc.), see chapters 5 and 13.

For all orders, please specify: Model + Dimensions + Material

1: Model	2: Dimensions	3: Material
VSD Please refer to the table	Ø 25 Please refer to the table	SI Please refer to the table

E.g. VSP 2258 SIT7
(VSP 2258 suction pad in 70 shore translucent silicone)



Branch-specific applications

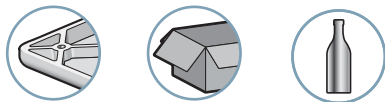

Presentation

Long stroke suction pads (3.5 and 4.5 bellows) are specially recommended for handling spherical or cylindrical objects or which require compensation for varying heights.

Types of use



Materials

NBR Nitrile
SIT3 35 shore translucent silicone
SIT5 50 shore translucent silicone

3

	Volume (cm ³)	Force (N) ⁽¹⁾	Deflection (mm) ⁽²⁾	NBR	SIT3	SIT5	Weight (g)
VSB 25	7.2	8	27	■		■	5
VSD 18	2.5	5.5	18			■	3.2
VSD 32	21.7	14.5	34	■	■		13.4

(1) Force at 90 % vacuum including a safety factor of 2.

(2) f = Deflection of the suction pad.

VSB 25

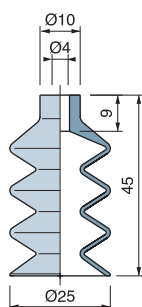

VSD 18

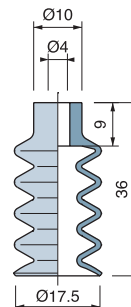

VSD 32

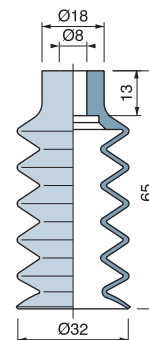

Choice of fitting

(Ø)	Group		M5M	M6M	M8M	M10M	1/8F	1/8M	10/32M	1/4F	1/4M
VSB 25 / VSD 18	1	2/15	■	■			■	■	■		
VSD 32	2	2/16	■	■	■	■	■	■		■	■

Fitting: M = male
F = female

Assembly diagrams

see pages 2/15 and 2/16.

Accessories

To optimize use of your suction pads, Coval offers a comprehensive range of accessories (sensors, spring extensions, and feeder systems, etc.), see chapters 5 and 13.

For all orders, please specify: Model + Material

1: Model	2: Material
VSB 25	NBR
VSD 18	SIT3
VSD 32	SIT5

E.g. VSD 18 SIT5
(VSD 18 suction pad in translucent silicone)



Branch-specific applications



Types of use



3

Materials

NBR Nitrile
NR Natural rubber

Presentation

Designed for gripping 75 cl bottles, the VSBO range of suction pads has been extended to include a suction pad specially developed to grip Magnum bottles. The curve and surface of the lip are adapted to the weight and diameter of this size of bottle.

The VSBO bottle suction pads are designed to hold bottles from the side for vertical and horizontal handling.

Two fitting types: to provide users with maximum possibilities, the bottle suction pads have an M6 internal thread which allows the suction pads to be attached either from inside with 2 x M5 screws or from above with 2 x M6 screws.



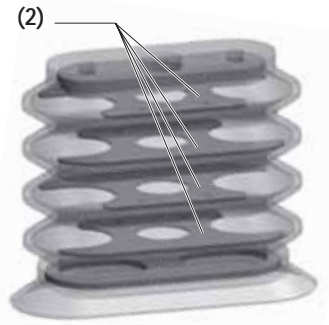

The VSBO suction pad is fitted with 4 stainless steel reinforcements in the bellows(2) to increase the tensile force whilst maintaining a long stroke and high flexibility.



Characteristics

The actual force is 80 Newtons at 90% vacuum with a safety factor of 2 included (VSBO fitted with internal reinforcements)

The force of the lip is stronger to increase resistance to slipping (VSBO 50105, etc.).

	 (cm ³)	 (N) ⁽¹⁾	 (N) ⁽¹⁾	deflection (mm)	NBR	NR
VSBO 4095	112.5	80	40	38	■	■
VSBO 50105	142.5	80	50	2.5 + 38	■	

(1) Actual force of the suction pad with a 90% vacuum and including a safety factor of 2 for horizontal handling and a factor of 4 for vertical handling.

CAVSBO valve option for VSBO 4095

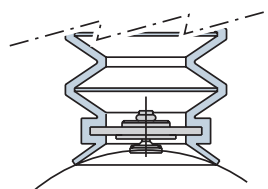

The CAVSBO valve has been specially developed for the VSBO 4095 NBR suction pad. It ensures that the network remains air-tight even if there is no bottle.

- 100% air-tight
- Simple and reliable

Note: high valve on request.

Reference of CAVSBO valve replacement kit (valve pin + spring + seal):
CAVSBO KIT

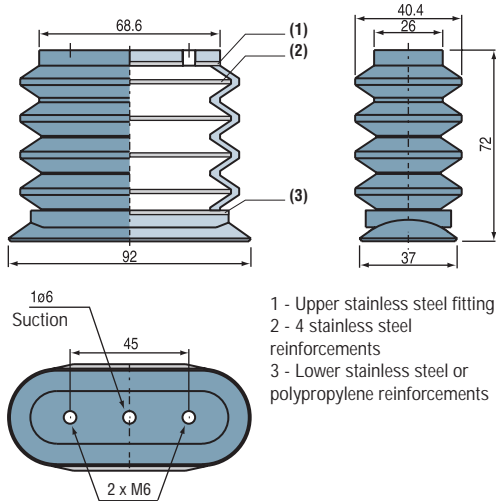

75 cl bottle suction pad - VSBO 4095

	material	reinforcement	
VSBO 4095	NBR	D5	lower stainless steel reinforcement
	NR	D5P	Lower polypropylene reinforcement

■ E.g. VSBO4095NBRD5P

VSBO4095 suction pad in nitrile with upper fitting, 4 stainless steel reinforcements and lower polypropylene reinforcement.

■ Replacement suction pad: VSBO4095NBR or NR

■ Option: CAVSBO valve

VSBO 4095 NBR D5 or D5P can be transformed to VSBO 50105 NBR D5 by ordering the kit ref. **VPBO 50105 M**

+

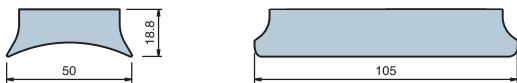

VPBO 50,105 M

Including the 50 x 105mm lip with reinforcement to be mounted under the VSBO4095 suction pad.

Kit ref: VPBO50105M

=

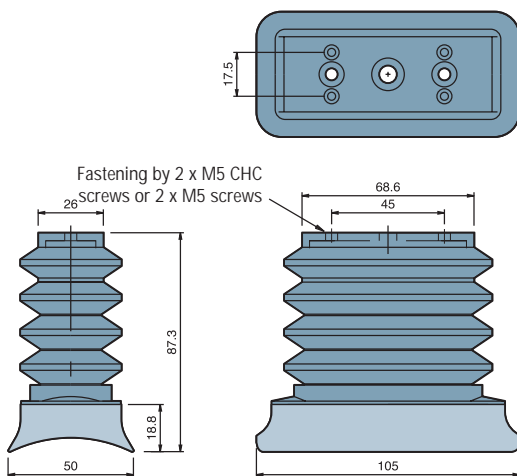

Magnum bottle suction pad fitted with internal reinforcements VSBO 50105 NBR D5

Suction pad with 4 bellows with:

- a 50 x 105 nitrile lip
- 4 stainless steel internal reinforcements
- a lower stainless steel reinforcement

Ref: VSBO 50105 NBD5

Replacement lip: ref. VPBO 50105 NBR



Branch-specific applications

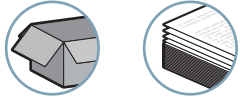

Presentation

The VPA series suction pads for paper are made of natural rubber (NR) to ensure resistance to abrasion caused by paper and cardboard or of silicone (SIT5) for food compatibility. A range of suction pads with a very flexible lip used to handle highly flexible materials

Types of use

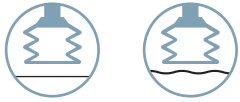

Materials

NBR Nitrile
SIT5 50 shore translucent silicone
NR Natural rubber

3

Suction pad icon	N (N) ⁽¹⁾	NBR	SIT5	NR	ØA (mm)	H (mm)	Ød (mm)	ØD (mm)	f (mm)	B (mm)	male fittings				female fittings	
											1/8G	1/4G	M5	M6	1/8G	1/4G
VPA 15	4		■	■	15	9.8	5	9	0.8	7	IM11A		IM21	IM22	IF10A	
VPA 20	6	■	■	■	20	10.3	5	10	1.3	7	IM11A		IM21	IM22	IF10A	
VPA 25	9		■	■	25	10.8	5	10	1.8	7	IM11A		IM21	IM22	IF10A	
VPA 26	9			■	25	21.5	6	14	1.9	13.5						
VPA 30	13	■	■	■	30	23	11	15	2.5	16		IM51SP143	IM5VPA30			IF50SP143
VPA 35 A	17			■	35	23	11	15	2.5	16		IM51SP143	IM5VPA30			IF50SP143
VPA 40	29		■	■	40	20	8	16	2	15		IM41SP477				IF40SP477
VPA 25000	10		■	■	25.5	20	5.8	11	3	15.8						
VPA 25001	10		■	■	25.5	9.5	5.8	11	3	5.1	IM18D6		IM5D6		IF10ASP082	

(1) Actual force of the suction pad with a 90% vacuum and a safety factor of 2 included.

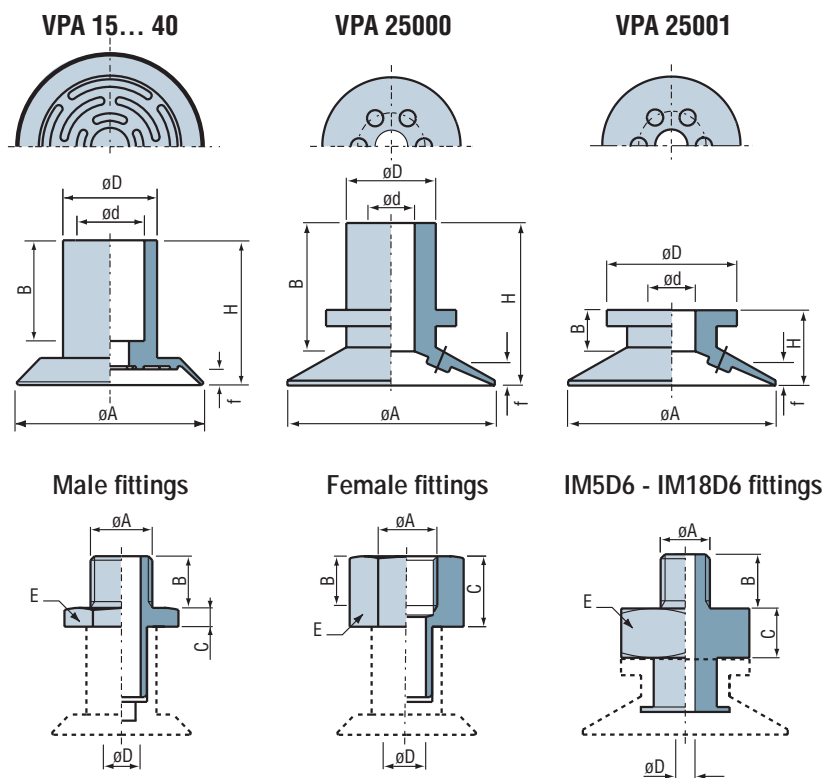

male fittings					
model	ØA (mm)	B (mm)	C (mm)	ØD (mm)	E (mm)
IM11A	1/8G	7.5	6	3.5	14
IM21	M5	4.5	5	2.5	7
IM22	M6	5	5	3.5	7
IM51SP143	1/4G	11	6	8	21
IM41SP477	1/4G	11	4	4.4	17
IM18D6	1/8G	7.5	5	3.5	17
IM5D6	M5	5.5	4.5	2	13
IM5VPA30	M5	5	3	2.5	13

female fittings					
model	ØA (mm)	B (mm)	C (mm)	ØD (mm)	E (mm)
IF10A	1/8G	8	12	3.5	14
IF50SP143	1/4G	10	15	8	21
IF40SP477	1/4G	10	15	4.4	17
IF10ASP082	1/8G	8	12	3.5	14

Accessories

To optimize use of your suction pads, Coval offers a comprehensive range of accessories (feelers, spring extensions, and feeder systems, etc.), see chapters 5 and 13.

For all orders, please specify: Model + Material

1: Model	2: Material
VPA 15 Please refer to the table	NBR Please refer to the table

E.g. VPA 20 NR
 (VPA 20 series suction pad, in natural rubber)

VPR series

Suction pads for mailing applications



Applications

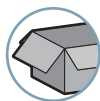

Types of use

Presentation

The COVAL range of mailing application suction pads is designed to meet the requirements of the mailing industry. The improved characteristics mean you can optimize production equipment in your branch, such as:

- Envelope stuffing
- Film wrapping
- Envelope insertion
- Mailing (picking).

Advantages

- Longer life expectancy
- Optimized for high throughput rates
- Excellent resistance to abrasion and slipping
- 100% compatible with machines currently on the market

Material

NR Natural rubber

	Ø A (mm)	H (mm)	Ø d (mm)	Ø d1 (mm)	Ø D (mm)	B (mm)	NR	colour
VPR 001	24.4	15	5.9	7.8	13.8	8	■	green
VPR 002	25.7	14.5	5.9	7.8	14	9	■	brown
VPR 003	20	14.2	5.7	4	13.8	6	■	red
VPR 004	20	14.2	5.7	5	14.8	6	■	black

VPR 001 - 002

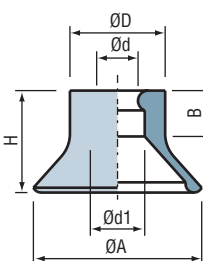

VPR 003 - 004

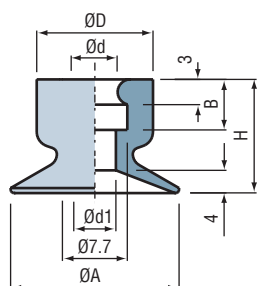

For all orders, please specify: Model

1: Model

VPAG Please refer to the table

E.g. VPR 003 (VPR 003 red suction pad)

VPAG series

Rounded suction pads



Applications

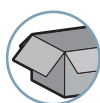

Types of use

Presentation

Thanks to very flexible lips, the VPAG range is ideally suited to gripping flexible materials such as labels or sheets of paper - or textured objects. Their shape allows them to be used for unstacking.

Materials

NR Natural rubber

	NR
VPAG 25	■
VPAG 3536	■

VPAG 25

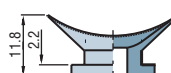
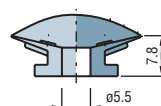

VPAG 3536

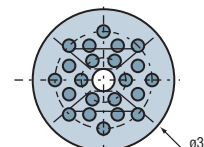
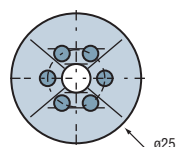
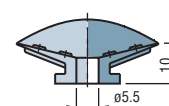

Fitting for VPAG 25

1/8 G M IM11ASP082

1/8 G F IF10ASP082

For all orders, please specify: Model + Material

1: Model

VPAG Please refer to the table

2: Material

NR

E.g. VPAG 3536 NR (VPAG 3536 suction pad in natural rubber)

Accessories

To optimize use of your suction pads, Coval offers a comprehensive range of accessories (sensors, spring extensions, and feeder systems, etc.), see chapters 5 and 13.

VPV, VSAV, VSV, VSAOV series

Anti-abrasion suction pads



Branch-specific applications

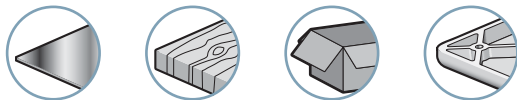

Types of use



Presentation

The most significant aspect of these suction pads is their **exceptional resistance to abrasion**. They are much more hard-wearing than standard elastomers. They are used for handling cardboard boxes or paper (extremely abrasive) at high throughput rates in packaging machines and injection presses.

Characteristics of the materials

This polyurethane is the cross-over point between elastomers (NBR, CR, NR, etc.) and plastics.

Some mechanical characteristics:

- High mechanical resistance, high rebound elasticity.
- Excellent resistance to slipping thanks to the structure of the lips.
- Excellent resistance to tearing.
- Quickly returns to former shape after compression.
- High resistance to mineral oils, grease, petrol and a large number of solvents.

Specifications

- Shore Hardness
72° Shore ± 5° (according to Standard DIN 53505).
- Operating temperature
-40 to 80°C / -40 to 176°F for long gripping,
-40 to 100°C / -40 to 212°F for short gripping,
- Color
Translucent green.

Life expectancy

Tests show suction pad operations are multiplied by 4 to 10 depending on the application (abrasion, temperature, etc.) and depending on the elastomer initially used.

Icon	Ø (mm)	Volume (cm ³)	Force (N) ⁽¹⁾	Force (N) ⁽¹⁾	R _{min} (mm)	f (mm)	Connection to the vacuum system				
							IM14 1/4G	IF14 1/4G	IM18 1/8G	IF18 1/8 G	IF12 1/2 G
VPV 15	15	0.5	6.4	3.2	15	1.5			■	■	
VPV 30	30	1.7	24	12	26	3			■	■	
VPV 50	50	6	71	35	75	4.5	■	■			
VPV 60	61.5	15	97	48.5	75	6	■	■			
VPV 80	81.5	30	195	97.5	100	6	■	■			
VPV 95	96.5	42	262	131	140	6	■	■			
VSAV 30	30	4.2	10	5	25	8.5	■	■			
VSAV 40	40	11.3	24.7	12	30	12.8	■	■			
VSAV 50	50	22.6	38.9	19.4	40	14.5	■	■			
VSAV 60	60	31	56.2	28.1	50	12.5	■	■			
VSAV 85	85	78	105	52.5	80	15	■	■			
VSAV 110	110	350	221	110	100	30					■
VSV 30	30	9	10.1	5	25	15	■	■			
VSV 60	60	61	45.7	22.8	50	30	■	■			
VSV 85	85	195	90	45	60	38	■	■			
VSAOV 4095	40 x 95	31	72	36	20	12			■		
VSAOV 65140	65 x 140	89	168	84	30	16	■				

(1) Force with a 90% vacuum including a safety factor of 2 for horizontal handling and a factor of 4 for vertical handling.

(2) f = Deflection of the suction pad.

For all orders, please specify: Model + Connection to the vacuum system

1: Model

VPV 15 Please refer to the table

2: Connection to the vacuum system

IM14 Please refer to the table

E.g. VPV 80 IF14 (VPV series suction pad, diameter 80 with fitting 1/4 Gas female)

or: VPV 80 (VPV series suction pad, diameter 80 without fitting)

VPV, VSAV, VSV, VSAOV series

Dimensions and technical data

Dimensions

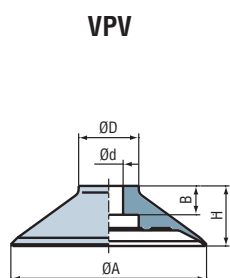

VPV

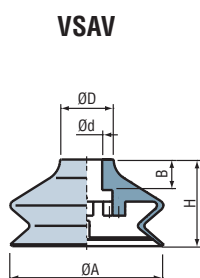

VSAV

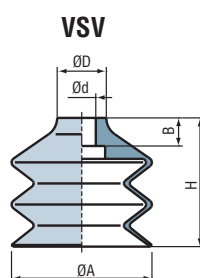

VSV

Fitting for VPV - VSAV - VSV

female

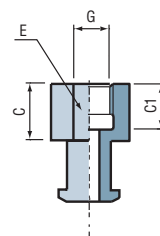

male

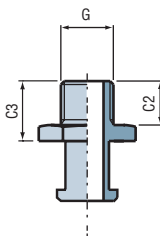

VSAV 110

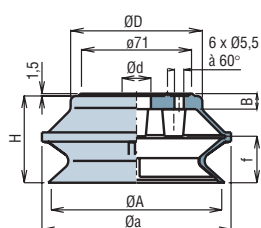

VSAV 110 IF12

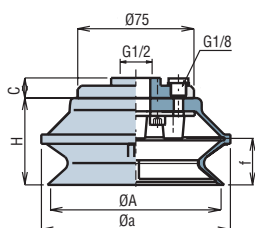

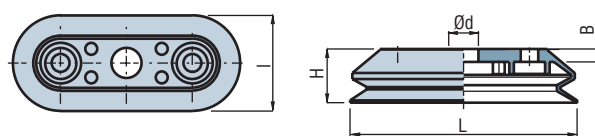

VSAOV

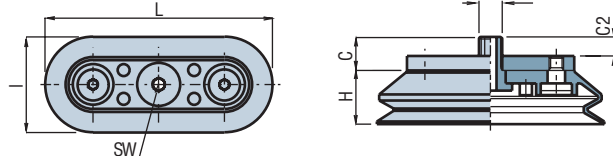

VSAOV IM18 / IM14



	Ø A (mm)	Ø d (mm)	Ø D (mm)	H (mm)	B (mm)	C (mm)	C1 (mm)	C2 (mm)	C3 (mm)	Ø a (mm)	G	E (mm)
VPV 15	15	4,5	11,5	9,5	2,5	16	9	8	13	-	1/8G	14
VPV 30	30	6	16	13	7	16	9	8	13	-	1/8G	14
VPV 50	50	8	18	17	8	15	12	10	15	-	1/4G	17
VPV 60	61,5	8	20	18,5	8	15	12	10	15	-	1/4G	17
VPV 80	81,5	12	25	25	12	15	12	10	15	-	1/4G	22
VPV 95	96,5	12	31	25	12	15	12	10	15	-	1/4G	22
VSAV 30	30	8	18	27	12	15	12	10	15	-	1/4G	17
VSAV 40	40	8	14	26	8	15	12	10	15	-	1/4G	17
VSAV 50	50	8	17,5	32,5	8	15	12	10	15	-	1/4G	17
VSAV 60	60	12	21	34	12	15	12	10	15	-	1/4G	17
VSAV 85	85	12	25	47	20	15	12	10	15	-	1/4G	22
VSAV 110	110	19	85	56	10	13	-	-	-	122	1/2G	-
VSV 30	30	8	18	40	12	15	12	10	15	-	1/4G	17
VSV 60	60	12	21	55	12	15	12	10	15	-	1/4G	17
VSV 85	85	12	25	85	20	15	12	10	15	-	1/4G	22
VSAOV 4095	11.5	11.5	7.5	23.5	6.5	16.5	-	8	-	-	1/8G	-
VSAOV 65140	15.5	15.5	9.5	30	8.5	18	-	10	-	-	1/4G	-

	I (mm)	L (mm)	SW (mm)
VSAOV 4095	40	95	4
VSAOV 65140	65	140	8

The values represent the average characteristics of our products.

Accessories

To optimize use of your suction pads, Coval offers a comprehensive range of accessories (feelers, spring extensions, and feeder systems, etc.) see chapters 5 and 13.



Branch-specific applications

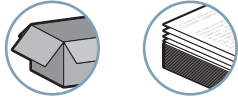

Presentation

VPS suction pads are used to handle fragile objects.

- Suction pads with extra-long shafts

Types of use



Materials

NBR Nitrile Si Silicone

3

	ØA (mm)	Volume (cm ³)	Force (N) ⁽¹⁾	R _{min} (mm)	H (mm)	Ød (mm)	ØD (mm)	Ød1 (mm)	f ⁽²⁾ (mm)	B (mm)	C (mm)	NBR	Si
VPS 6.3	6.3	0.017	1	8	12	2	4	0.5	1.5	8.5	9.5	■	■
VPS 10	10	0.065	2.5	10	13	3	5	2	2	8	9	■	■
VPS 16	16	0.330	4.5	15	20	5	8	3	4	12	14	■	■
VPS 25	25	1.00	13.5	20	30	8	12	4	5	18	22	■	■

(1) Actual force of the suction pad with a 90% vacuum and a safety factor of 2 included.

(2) f = Deflection of the suction pad.

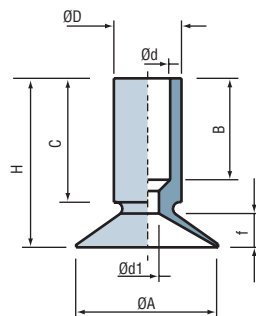

Suction pad with fitting

- M5 male fitting for VPS 6.3 to 16: add IMM5 to the suction pad reference.
- 1/8 G male fitting for VPS 25: add IMM5 to the suction pad reference.

	C2 (mm)	C3 (mm)	D (mm)	G (mm)	H (mm)
IMM5	4.5	7.5	1	M5	8
IM18	8	13	3.5	1/8G	14

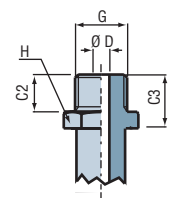

Accessories

To optimize use of your suction pads, Coval offers a comprehensive range of accessories (feelers, spring extensions, and feeder systems, etc.) see chapters 5 and 13.

For all orders, please specify: Model + Material + Fitting

1: Model	2: Material	3: Fitting
VPS 16 Please refer to the table	NBR or Si	IMM5 or IM18

E.g. VPS 16 NBR IMM5

(VPS series suction pad, diameter 16 in Nitrile with M5 male fitting)

VCD, VPCD series CD suction pads



Branch-specific applications



Presentation

VCD and VPCD suction pads are specifically used to handle delicate objects at a high throughput rate (CDs, DVDs).

- Excellent resistance to high temperatures (silicone).

Types of use



Materials

SIT3 30 shore translucent silicone SI Silicone
 SIT4 40 shore translucent silicone
 SIT5 50 shore translucent silicone

	(N) ⁽¹⁾	SIT3	SIT4	SIT5	SI	(g)
VCD 24	5.3		■			1.5
VCD 31	21.2				■	1.8
VCD 24 G	5.3		■			3.7
VCD 34	17.3			■		2.1
VCD 17 ⁽²⁾	8.3	■				1.1

(1) Actual force of the suction pad with a 90% vacuum including a safety factor of 2.

(2) Half-moon suction pads available on request.

VCD 24

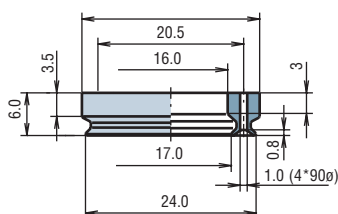

VCD 31

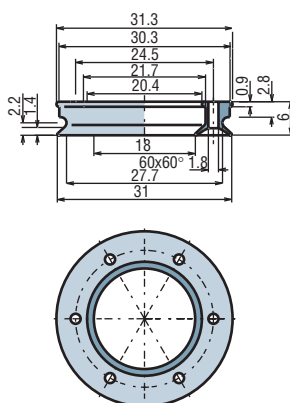

VCD 24 G

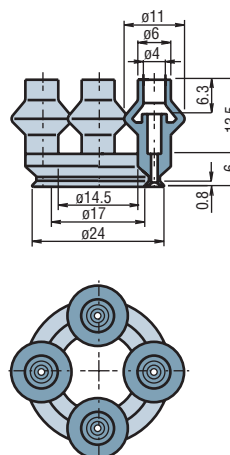

VCD 34

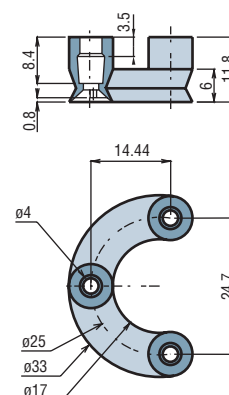

For all orders, please specify: Model + Material

1: Model

VCD 24 Please refer to the table

2: Material

SIT3 Please refer to the table

E.g. VCD 24 SIT4 (VCD 24 suction pad in translucent silicone SIT4)

VPCD 8 SI

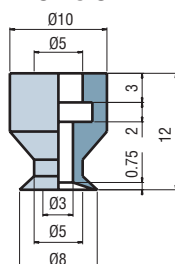

Materials

SI 50 shore pink silicone

	(N) ⁽¹⁾	SI	(g)
VPCD 8 SI	1.3	■	0.54



Branch-specific applications

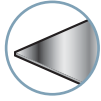

Presentation

VPYR series ball-joints are recommended for gripping rounded or rotating products. They are also recommended for gripping requiring high mechanical resistance and force.

Types of use



3



Materials

Suction pads:

NBR Nitrile
Si Silicone

Ball-joint:

Nickel-plated brass and zinc-plated steel

	 (N) ⁽¹⁾	R_{min} (mm)	NBR	Si	Ø A (mm)	B (mm)	C (mm)	D (mm)	f ⁽²⁾ (mm)	 (g)
VPYR 50	90	41	■	■	50	60	12	42	4	117
VPYR 60	129.7	70	■	■	60	93	16	58	5	352
VPYR 80	230	100	■	■	80	95	18	60	6	444
VPYR 100	360	150	■	■	100	95	18	60	6	568

(1) Actual force of the suction pad with a 90% vacuum including a safety factor of 2.

(2) f = Deflection of the suction pad.

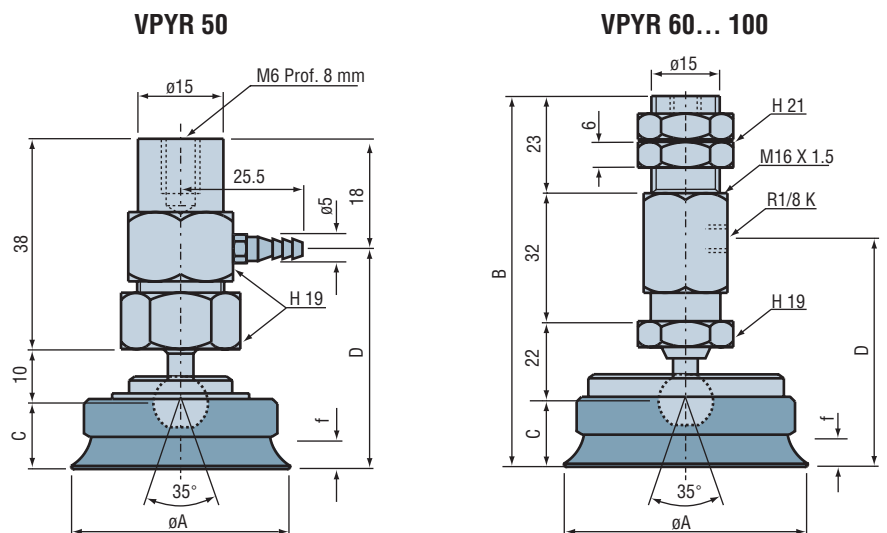

Replacement suction pad

If the suction pad becomes worn, the VPR suction pad can be ordered alone, specifying the diameter (Ø A) and material of the suction pad.

Accessories

Possibility of telescopic spring-mounting on request.

For all orders, please specify: Model + Material

1: Model	2: Diameter	3: Material
VPYR	50 Ø 50	NBR
	60 Ø 60	Si
	80 Ø 80	
	100 Ø 100	

E.g. VPYR 50 NBR
(VPYR series radial ball-joint suction pad, Diameter 50, in Nitrile)

or: VPYR 50 NBR (VPR series suction pad, Diameter 50, in Nitrile)



Branch-specific applications

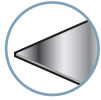

Types of use



Presentation

SPL suction pads are used to handle heavy loads such as metal sheets or glass panels. They have internal cleats allowing them to handle thin metal sheets without distorting them and for vertical handling (non-slip).

SPL suction pads are delivered without holes for fittings or with your choice from our range of standard models or specific models on request.

Materials

NBR Nitrile Si Silicone

Icon	ØA (mm)	Volume (cm ³)	Force (N) ⁽¹⁾	Force (N) ⁽¹⁾	H (mm)	ØD (mm)	f ⁽²⁾ (mm)	NBR	Si	Fitting ⁽³⁾	Weight (kg)
SPL 240	240	510	1800	900	28	200	14	■	■	Steel	2.2
SPL 340	340	720	3800	1900	32	300	15	■	■	Steel	5.5
SPL 400	400	850	5000	2500	46	300	25	■	■	Steel	7.6
SPL 500	500	1050	8000	4000	46	400	25	■	✱	Steel	12
SPL 600	500	1300	11000	5500	46	500	25	■	✱	Acier	18

■ Standard / ✱ On request

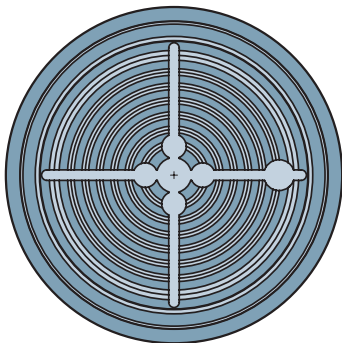
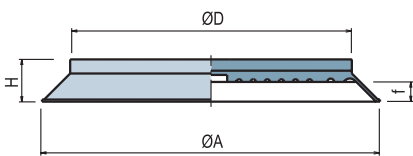

(1) Actual force of the suction pad in use with a 90% vacuum and including a safety factor of 2 for horizontal handling and a factor of 4 for vertical handling.

(2) f = Deflection of the suction pad.

(3) Thickness of the steel fitting: 8 mm.

Standard internal threads

The threads given below are for mounting on the COVAL spring systems (not supplied with the suction pad).

Icon	TS 560 + IFA 12120	RSC1 ⁽¹⁾	RSC 2 ⁽¹⁾
SPL 240	■	■	-
SPL 340	■	■	■
SPL 400	-	-	■



(1) A 3/8 G internal thread is available for connection to the vacuum system.

RSC1: specify **G38 RS1** in the reference when ordering,
RSC2 : specify **G38 RS2** in the reference when ordering,

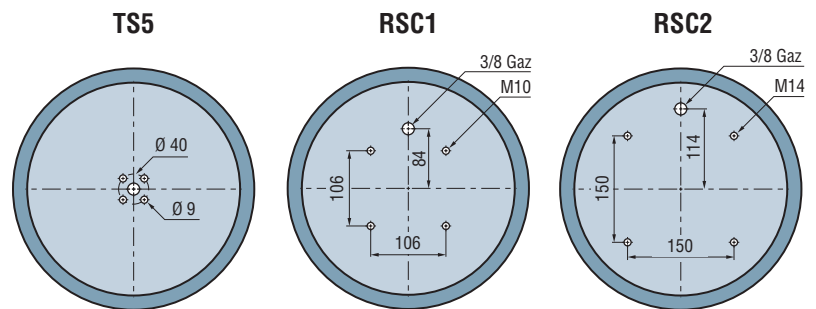

Accessories

Suction pads from the SPL series can be mounted on RSC series spring systems. SPL 240 suction pads can be mounted on the IFA 12 120 fitting and the TS560 spring system. See page 5/3.

For all orders, please specify: Model + Material + Internal thread

1: Model	2: Material	3: Internal thread
SPL	Please refer to the table	NBR or Si
		G38 RS1
		—

E.g. **SPL 240 NBR G38 RS1**

(SPL series suction pad, diameter 240 in Nitrile with internal thread for the COVAL spring system and 3/8 Gas for connection to the vacuum system)

Branch-specific applications

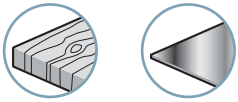

Types of use



Presentation

For horizontal handling of heavy loads (thick metal sheets) or objects with an uneven surface such as concrete slabs or wood, etc.

Advantage: wide choice of shapes and dimensions.

Materials

Body stainless steel
Foam seal Nitrile

Characteristics

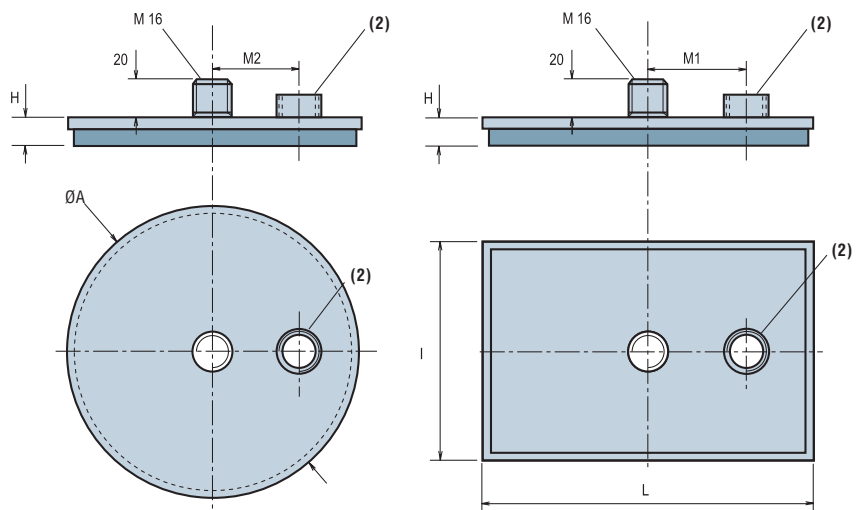

Fittings

5000 An ring fitting

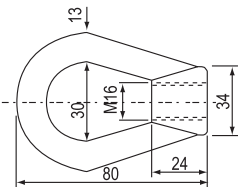

5000 Ch cap fitting

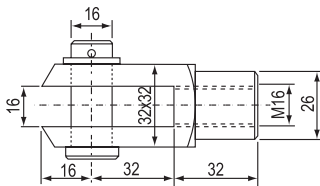

Round suction pads				Rectangular suction pads								
	ØA (mm)	H (mm)	(N) ⁽¹⁾		L (mm)	I (mm)	H (mm)	M1/M2 (mm)	Con. ⁽²⁾	(N) ⁽¹⁾	Type of seal	
5020	150	25	430	6020	175	115	25	40	1/4G	460	BM 2020 SPTR	
5028	170	25	600	6028	215	115	25	45	1/4G	590	BM 2020 SPTR	
5035	190	25	790	6035	225	125	25	50	1/4G	710	BM 2020 SPTR	
5050	210	25	1020	6050	250	150	25	60	1/4G	1040	BM 2020 SPTR	
5085	260	25	1710	6085	305	180	25	70	1/4G	1670	BM 2020 SPTR	
5150	350	35	2970	6150	410	250	35	80	3/8G	2990	BM 3030 SPTR	
5240	420	35	4580	6240	480	310	35	100	3/8G	4730	BM 3030 SPTR	
5330	500	35	6840	6330	575	330	35	120	3/8G	6260	BM 3030 SPTR	
5500	580	35	9550	6500	705	385	35	140	3/8G	9430	BM 3030 SPTR	

(1) Force measured at 90% vacuum including a factor of 2.

For all orders, please specify: Round suction pad: Model + Diameter + Fitting model

1: Model	2: Fitting model	
5020 to 6500	Ring	5000 An
	Cap	5000 Ch

Option

Spring system mounting, see page 5/3.

E.g. 6050 5000 An
(Rectangular steel suction pad 250 x 150mm with 5000 An ring fitting).



Branch-specific applications

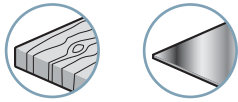

Types of use



Fittings

- 5000 An ring fitting

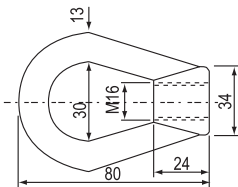

- 5000 Ch cap fitting

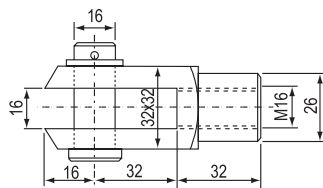

Presentation

For horizontal handling of heavy loads (thick metal sheets) or objects with an uneven surface such as concrete slabs or wood, etc.

Easier maintenance; no more tricky bonding. The seal is clipped onto the metal fitting and held in place with a stainless steel wire.

Materials

Body	Painted steel	Ring and clip	Stainless steel
Foam seal	Nitrile		

Characteristics

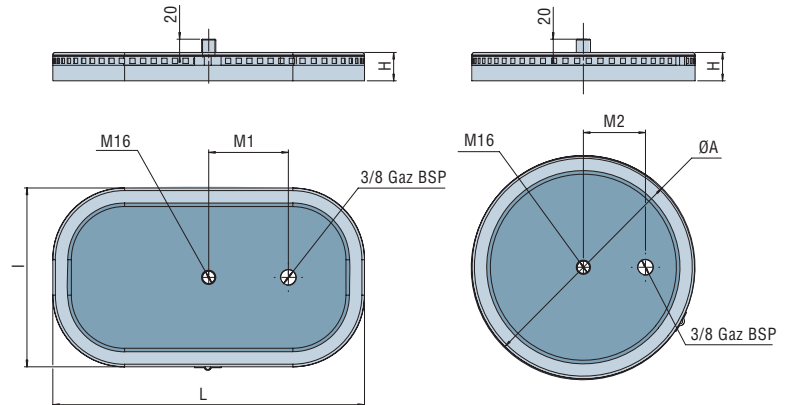

Round suction pads				Rectangular suction pads							
	ØA (mm)	H (mm)	(N) ⁽¹⁾		L (mm)	I (mm)	H (mm)	M1/M2 (mm)	Con.	(N) ⁽¹⁾	Type of seal
VA 250	250	32	1500	VA 300	300	200	32	70	3/8G	1500	BM 2015 ELASTO
VA 280	280	32	2000	VA 330	330	220	32	70	3/8G	2000	BM 2015 ELASTO
VA 310	310	32	2500	VA 360	360	230	32	70	3/8G	2500	BM 2015 ELASTO
VA 330	330	32	3000	VA 390	390	250	32	80	3/8G	3000	BM 2015 ELASTO
VA 360	360	32	3500	VA 420	420	270	32	80	3/8G	3500	BM 2015 ELASTO

(1) Force measured at 90% vacuum including a factor of 2.

Spare parts

- Foam seal, ref. BM 2015 ELASTO (sold by the meter)
- Stainless steel collar, ref. 095 06 108 (sold by the meter)
- Stainless steel clip, ref. 095 06 109.

on request:

- Full kit for replacement of removable seal.



For all orders, please specify:

Round suction pad: Model + Diameter + Fitting model

1: Model	2: Diameter	3: Fitting model
VA	250 to 360mm	Ring 5000 An Cap 5000 Ch

Rectangular suction pad: Model + Length + Width + Fitting model

1: Model	2: Length	3: Width	4: Fitting model
VA	300 to 420mm	200 to 270mm	Ring 5000 An Cap 5000 Ch

Option

- Spring system mounting, see page 5/3.

E.g. VA 250 5000 An

(VA series suction pad, diameter 250 with 5000 An ring fitting).

Generic suction pads for replacement

COVAL QUALITY

Some of our customers have sometimes used suction pads made by other manufacturers adapted to their applications. To satisfy them we have developed a range of generic suction pads which are 100% compatible with their application. Please contact your COVAL correspondent for further information regarding generic solutions.

VPU



- Flat suction pads
- Ø 6 to 50mm
- 2 standard materials (Nitrile and silicone)

P_{4/2}

■ Range of generic VPU flat suction pads

VSAB

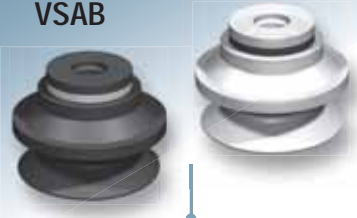

- Suction pads with 1.5 bellows
- Ø 5 to 50mm
- 2 standard materials (Nitrile and silicone)

P_{4/4}

■ Range of generic VSAB suction pads with 1.5 bellows

VSAG



- Suction pads with 1.5 bellows
- Ø 10 to 150mm
- 4 standard materials

P_{4/6}

■ Range of generic VSAG suction pads with 1.5 bellows

VSAJ



- Suction pads with 1.5 bellows
- Ø 15 to 30mm
- 2 standard materials (Nitrile and silicone)

P_{4/8}

■ Range of generic VSAJ suction pads with 1.5 bellows

VSG



- Suction pads with 2.5 bellows
- Ø 5 and 7mm
- 5 standard materials

P_{4/9}

■ Range of generic VSG suction pads with 2.5 bellows



Branch-specific applications



Presentation

- Range of generic VPU flat suction pads.





Types of use



Materials

- NBR Black nitrile
- SI Translucent silicone

4

	Ø (mm)	 (cm ³)	 (N) ⁽¹⁾	 (N)	 (mm)	NBR	Si
VPU 6	7	0.05	1.3	0.6	5	■	■
VPU 8	9	0.1	2	1	6	■	■
VPU 10	11	0.18	3.5	1.7	8	■	■
VPU 15	16.5	0.5	6	3	8	■	■
VPU 20	22	1	9	4.5	13	■	■
VPU 30	32	2	18	9	20	■	■
VPU 40	41	5.5	26	13	30	■	■
VPU 50	51.4	12	46	23	35	■	■

(1) Actual force of the suction pad in use with a 90% vacuum and including a safety factor of 2 for horizontal handling and a factor of 4 for vertical handling.

Choice of fittings

	M5 M	1/8G M	1/4G M
VPU 6	IMM5P1		
VPU 8	IMM5P1		
VPU 10	IMM5P2		
VPU 15	IMM5P2		
VPU 20		IM18P3	
VPU 30		IM18P3	
VPU 40			IM14P4
VPU 50			IM14P5

Fittings: M = Male / F = Female

For all orders, please specify: Model + Material + Fitting

1: Model		2: Material	3: Fitting	
VPU 6	Please refer to the table	NBR or Si	IMM5	M5 male
			IM18	1/8G male
			IM14	1/4G male

E.g. VPU 20 NBR IM14
(VPU 20 series suction pad, in black nitrile with 1/4G male fitting)

Dimensions

VPU 6... 15

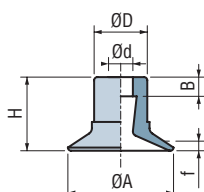

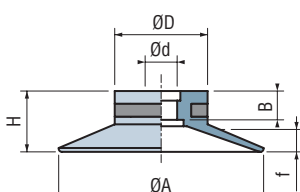

VPU 20... 30

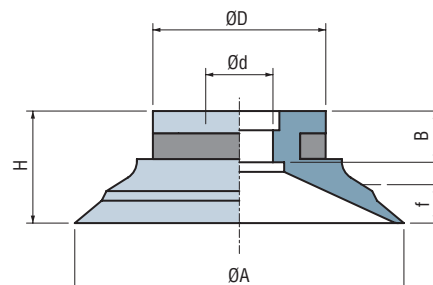

VPU 40 - 50



	Ø A (mm)	H (mm)	Ø d (mm)	Ø D (mm)	f ⁽¹⁾ (mm)	B (mm)	 (g)
VPU 6	7	6.5	2	5	0.3	3.5	0.14
VPU 8	9	7	2	5	0.5	3.5	0.16
VPU 10	11	10.5	3.8	9	0.5	3	0.65
VPU 15	16.5	11.5	3.8	8.3	1.5	3	0.7
VPU 20	22	8	5	14.5	2.5	4.5	1.2
VPU 30	32	9.5	5	14.5	3.5	4.5	1.8
VPU 40	41	13	6.5	20	4.5	6	4
VPU 50	51.4	17.5	10.5	27	6	8	10

The values represent the average characteristics of our products.

(1) f = Deflection of the suction pad.

Male fitting

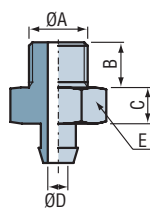

	ØA	B	C	ØD	E
IMM5P1	M5	4	3.5	1.5	7
IMM5P2	M5	4	4.5	2.7	7
IM18P3	1/8G	7	3.5	4	14
IM14P4	1/4G	9	6	5	17
IM14P5	1/4G	9	6	5	21

Accessories

To optimize use of your suction pads, Coval offers a comprehensive range of accessories (sensors, spring extensions, and feeder systems, etc.) see chapters 5 and 13.

Suction pads with 1.5 bellows Ø 5 to 50mm



Branch-specific applications



Presentation

- Range of generic VSAB suction pads with 1.5 bellows.

Types of use



4

Materials

- NBR Black nitrile
- SI Translucent silicone

	Ø (mm)	(cm ³)	(N) ⁽¹⁾	(N)	R _{min} (mm)	NBR	SI
VSAB 5	5.6	0.05	0.5	0.2	1.5	■	■
VSAB 8	8.8	0.15	1.3	0.6	1.9	■	■
VSAB 10	11	0.48	2.4	1.2	4	■	■
VSAB 15	15.7	1.1	4.2	2.1	5	■	■
VSAB 20	22	2.7	7	3.5	10	■	■
VSAB 30	34	10	16	8	15	■	■
VSAB 40	43	15	26	13	20	■	■
VSAB 50	53	32	44	22	30	■	■

(1) Actual force of the suction pad in use with a 90% vacuum and including a safety factor of 2 for horizontal handling and a factor of 4 for vertical handling.

Choice of fitting

	M5 M	1/8G M	1/4G M
VSAB 5	IMM5P1		
VSAB 8	IMM5P1		
VSAB 10	IMM5P2		
VSAB 15	IMM5P2		
VSAB 20		IM18P3	
VSAB 30			IM14P4
VSAB 40			IM14P4
VSAB 50			IM14P5

Fittings: M = Male / F = Female

For all orders, please specify: Model + Material + Fitting

1: Model		2: Material	3: Fitting	
VSAB 5	Please refer to the table	NBR or SI	IMM5	M5 male
			IM18	1/8G male
			IM14	1/4G male

E.g. VSAB 30 NBR IM14
(VSAB 30 series suction pad, in black nitrile with 1/4G male fitting)

Dimensions

VSAB 5... 15

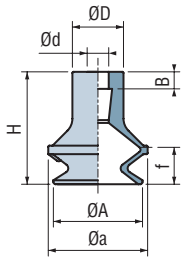

VSAB 20 - 30

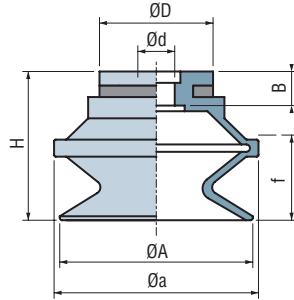

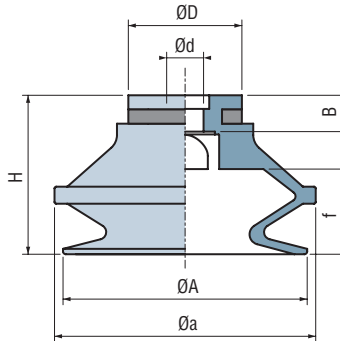

VSAB 40

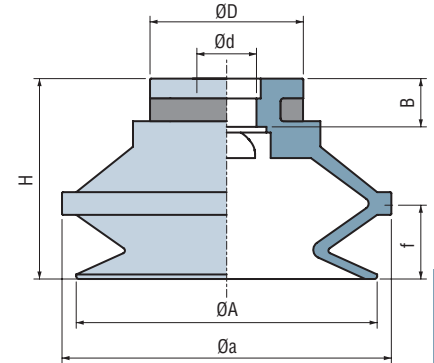

VSAB 50



	Ø A (mm)	H (mm)	Ø a (mm)	Ø d (mm)	Ø D (mm)	f ⁽¹⁾ (mm)	B (mm)	 (g)
VSAB 5	5.6	9.2	6.2	2	4.5	1.5	3.5	0.11
VSAB 8	8.8	11.9	9.6	2	5.5	3.5	3.5	0.3
VSAB 10	11	16.4	12	3.8	9	4.5	5	1
VSAB 15	15.7	19.8	17.5	3.8	9	6.5	3	1.5
VSAB 20	22	19	24	5	14.5	10	4.5	3.2
VSAB 30	34	26.2	36	6.5	20	15	6	7
VSAB 40	43	28	46	6.5	20	15	6.4	10
VSAB 50	53	35.3	58	10.5	27	13	8.5	20

The values represent the average characteristics of our products.

(1) f = Deflection of the suction pad.

Male fitting

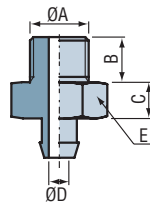

	ØA	B	C	ØD	E
IMM5P1	M5	4	3.5	1.5	7
IMM5P2	M5	4	4.5	2.7	7
IM18P3	1/8G	7	3.5	4	14
IM14P4	1/4G	9	6	5	17
IM14P5	1/4G	9	6	5	21

Accessories

To optimize use of your suction pads, Coval offers a comprehensive range of accessories (sensors, spring extensions, and feeder systems, etc.) see chapters 5 and 13.



Branch-specific applications

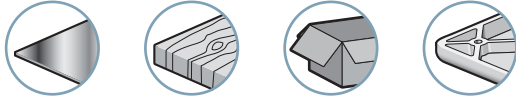

Presentation

■ Range of generic VSAG suction pads with 1.5 bellows.

Types of use







Materials

NBR Nitrile
SI Translucent silicone

STN Siton®
PUB Blue polyurethane

4



	Ø (mm)	 (cm ³)	 (N) ⁽¹⁾	 (N)	 (mm)	NBR	SI	STN	PUB
VSAG 10	10.7	0.2	2.5	1.3	4	■	■	■	■
VSAG 15	15	0.7	3.5	1.8	6	■	■	■	■
VSAG 20 B	20	1	6.6	3.3	8	■	■	■	■
VSAG 30	30	4	21	10.5	15	■	■	■	■
VSAG 40	40	9	32	16	30	■	■	■	■
VSAG 50	50	26	53	26	40	■	■	■	■
VSAG 75	75	76	125	62	70	■	■	■	■
VSAG 110	110	280	265	130	100	■	■	■	✱
VSAG 150	150	640	523	260	130	■	■	✱	✱

(1) Actual force of the suction pad in use with a 90% vacuum and including a safety factor of 2 for horizontal handling and a factor of 4 for vertical handling.

■ Standard

✱ On request

Choice of fitting

 (Ø)		M5 F	M5 M	M6 M	M8 M	M10 M	M10 125 pitch	1/8 F	1/8 M	1/4 F	1/4 M	1/2 F
10... 15	2/18	■	■					■	■			
20... 50	2/20			■	■	■		■	■	■	■	
75	2/21						■			■	■	
110, 150	2/21											■

■ Standard

Fitting: M = male
F = female

For all orders, please specify: Model + Diameter + Material

1: Model VSAG	2: Diameter 10 ... 150	3: Material NBR Please refer to the table
-------------------------	----------------------------------	---

E.g. VPYR 10 NBR (VSAG series suction pad, Diameter 10, in Nitrile)

Dimensions

VSAG 10 - 15

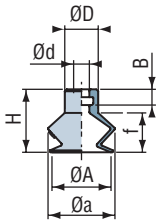

VSAG 20... 50

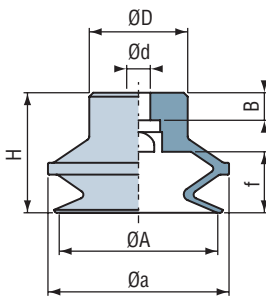

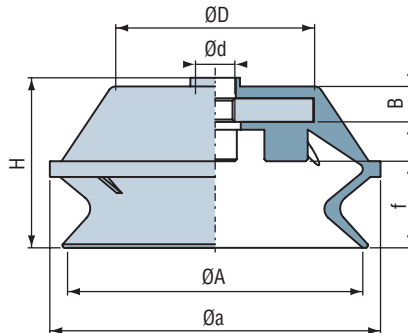

VSAG 75

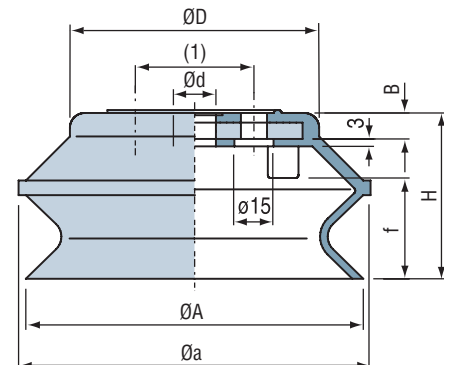

VSAG 110 - 150



(1) 4 holes Ø9 on Ø40

	Ø A (mm)	H (mm)	Ø a (mm)	Ø d (mm)	Ø D (mm)	f ⁽¹⁾ (mm)	B (mm)	 (g)
VSAG 10	10.7	13.3	12.5	4	8.5	7.5	4	0.6
VSAG 15	15	16	17	4	8.5	10	4	0.9
VSAG 20 B	20	22	24	6	15	12	7	3.1
VSAG 30	30	30.5	36	6	20	17	7	9
VSAG 40	40	30.5	46	6	25	15.5	7	14.8
VSAG 50	50	36.5	59.5	7.8	28.5	20	7	23.2
VSAG 75	75	43.2	84	M10 x 125	50.5	22	9	90
VSAG 110	110	55	121.5	14	85	32.5	9	320
VSAG 150	150	75.5	166	13	120	39.5	11	820

The values represent the average characteristics of our products.

(1) f = Deflection of the suction pad.

Types of assembly

Hollow shaft fitting:

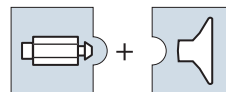

Removable insert:
(adapter and hollow screw)



Assembly diagrams

COVAL suction pads can be assembled in a wide variety of configurations.

see pages 2/18 to 2/21.

Accessories

To optimize use of your suction pads, Coval offers a comprehensive range of accessories (sensors, spring extensions, and feeder systems, etc.) see chapters 5 and 13.



Branch-specific applications



Presentation

- Range of generic VSAJ suction pads with 1.5 bellows .

Types of use



Materials

- NBR Nitrile
- SI Translucent silicone

4

	Ø A (mm)	Volume (cm ³)	Force (N) ⁽¹⁾	Force (N) ⁽¹⁾	R _{min} (mm)	H (mm)	Ø a (mm)	Ø d (mm)	Ø D (mm)	f ⁽²⁾ (mm)	B (mm)	Weight (g)	NBR	SI
VSAJ 15	15	0.5	5	2.5	10	11	15.5	4.5	12	3.3	3.5	0.8	■	■
VSAJ 20	20	1.2	9.5	4.7	13	13	21	4.7	15	5.5	4,5	1.7	■	■
VSAJ 30	30	3	18.5	9.2	26	17	30.6	5.8	20	7	7.2	5	■	■

The values represent the average characteristics of our products.

(1) Actual force of the suction pad in use with a 90% vacuum and including a safety factor of 2 for horizontal handling and a factor of 4 for vertical handling.

(2) f = Deflection of the suction pad.

- Standard

VSAJ 15

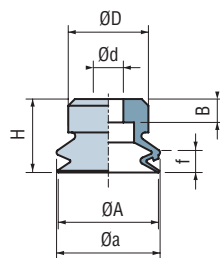

VSAJ 20

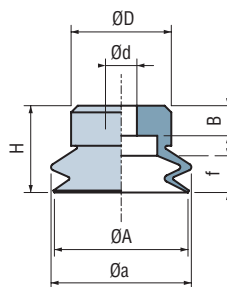

VSAJ 30

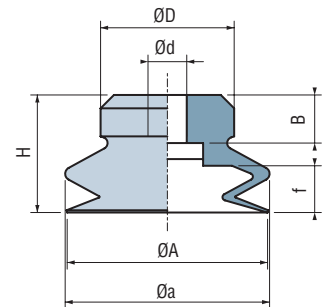

Choice of fitting

Ø	Sheet	M3 M	M5 M	M6 M	M8 M	M10 M	M10 125 pitch	1/8 F	1/8 M	1/4 F	1/4 M	1/2 F
15	2/19		■					■	■			
20	2/19		■					■	■			
30	2/20			■		■		■	■	■	■	

- Standard

Fitting: M = male
F = female

Assembly diagrams

see pages 2/19 and 2/20.

Accessories

To optimize use of your suction pads, Coval offers a comprehensive range of accessories (sensors, spring extensions, and feeder systems, etc.) see chapters 5 and 13.

For all orders, please specify: Model + Diameter + Material

1: Model

VSAJ

2: Diameter

15 ... 30

3: Material

NBR Please refer to the table

E.g. VSAJ 20 NBR (VSAJ series suction pad, Diameter 20, in Nitrile)



Branch-specific applications



Presentation

- Range of generic VSG suction pads with 2.5 bellows.

Types of use



Materials

NBR	Nitrile	PUB	Blue polyurethane
SI	Silicone	SIA	Antistatic silicone
STN	Siton®		

	Ø A (mm)	Volume (cm ³)	Force (N) ⁽¹⁾	R _{min} (mm)	H (mm)	Ø d (mm)	Ø D (mm)	f ⁽²⁾ (mm)	B (mm)	Weight (g)	NBR	SI	STN	PUB	SIA
VSG 5	5	0.03	0.5	3.5	9.5	4	7.5	3	4	0.2	■	■	■	■	■
VSG 7	7	0.04	1.4	4	10	4	7.5	3	4	0.23	■	■	■	■	■

The values represent the average characteristics of our products.

(1) Actual force of the suction pad in use with a 90% vacuum and including a safety factor of 2 for horizontal handling and a factor of 4 for vertical handling.

(2) f = Deflection of the suction pad.

■ Standard

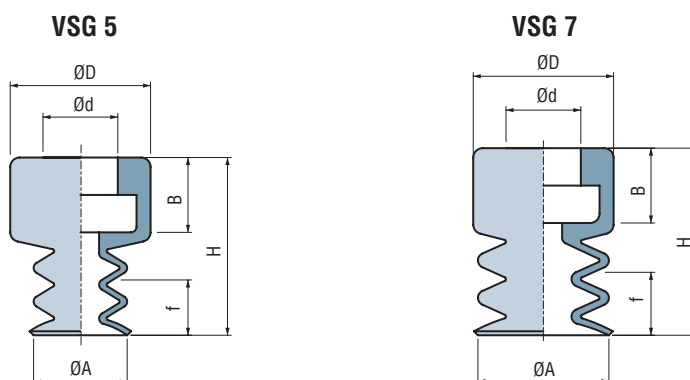

Choice of fitting

Ø	Sheet	M5 M	M5 F	1/8G M	1/8G F
5 and 7	2/18	IM5VPG5	IF5VPG5	IM18VPG5	IF18VPG5

■ Standard

Fitting: M = male
F = female

Assembly diagrams

See page 2/18

Accessories

To optimize use of your suction pads, Coval offers a comprehensive range of accessories (sensors, spring extensions, and feeder systems, etc.) see chapters 5 and 13.

For all orders, please specify: Model + Diameter + Material

1: Model	2: Diameter	3: Material
VSG	5 or 7	NBR Please refer to the table

E.g. VSG 5 NBR (VSG series suction pad, Diameter 5, in Nitrile)

TS, YS



- 6 models
- 5 to 70mm stroke available

P_{5/2}

- The TS and YS series spring systems are recommended for horizontal handling of objects located on different levels. The spring function also ensures the gripping points are applied on the same plane when gripping using multiple suction pads.

RSC



- 2 models
- 30mm stroke + 10° ball-joint effect
- Possibility of mounting on square tube with fitting system

P_{5/4}

- The system of 4 compensated springs is particularly recommended for horizontal handling requiring large diameter suction pads. The springs compensate for different levels between the suction pads (ball-joint effect)

5

TSOP, TSO



- 9 models
- Anti-rotation
- 7 to 40 mm stroke available
- Protected spring.

P_{5/5}

- The TSOP and TSO series anti-rotation spring systems are used for horizontal handling of objects at different levels. The anti-rotation function ensures that objects are always gripped in the same position

L



- 3 ranges (M1/4G, M1/8G and F3/8G)
- 3 possible strokes

P_{5/6}

- The L series extensions are used for gripping on various levels from the same installation plate. These extensions are adjustable to different heights

Nozzle fittings



- 9 models
- (Hollow screw or hollow shaft fitting)

P_{5/8}

- These fittings are designed for installations including a large number of suction pads connected to the same vacuum generator, particularly for situations where there may be objects missing in the layer of objects to be handled. Using nozzle fittings reduces the loss of flow and therefore optimizes the size of the vacuum generator.

PMG2



- Mechanical feelers
- 5 models
- For VP series Ø30 to 60mm suction pads

P_{5/9}

- The PMG2 series mechanical feelers are mounted on VP series diameter 30 to 60mm flat suction pads in all types of material. The feeler is actuated by the object to be handled, causing it to open and free the route for the vacuum

PBA



- Automatic shut-off valves
- 6 models
- (The PBA series is interchangeable with the old SVK or SV 14 reg series)

P 5/10

- With a centralized vacuum and no object under the suction pad, the suction causes the valve to close the vacuum inlet. Can be used with all shapes of suction pad. Constant minimum leakage on uncovered suction pads

PBP



- Leak sensing valves
- 3 models
- Sensor valve used for gripping porous or very dusty products

P 5/11

- The PBP series leak sensing valve is suitable for random gripping of very porous products such as cardboard and particle board, etc.
- The permanent leakage of the PBA series valve is not great enough to compensate for the porosity of the cardboard

PBE



- 4 models
- Air-tight sensor valves (ball technology)

P 5/11

- PBE series sensor valves are completely air-tight if no object is present, resulting in substantial savings at the vacuum source

IMUKGL, IMU



- Ball-joint fitting
- 4 models

P 5/12

- IMU and IMUKGL series ball-joints are recommended for gripping rounded products
- Fitted on a flat suction pad, they transmit more force than a bellows type suction pad.

CSP



- "Vacuum" check-valve
- Directly mounted on the suction pad
- Release by blow-off

P 5/13

- The CSP series safety valve is a useful safety device in the event of loss of vacuum or emergency stop as it maintains the vacuum in the suction pad. Release is obtained by connecting the ancillary coupling to the pressure

BM



- Foam strip (air-tight cells)
- 10 models
- 3 types of material (Nitrile, Silicone and Natural rubber)

P 5/14

- The foam ring is designed for gripping products with an uneven or ridged surface: sawn wood, metal sheets, flat surfaces with bumps or hollows.
- All granular surfaces to which suction pads cannot adhere correctly and therefore cannot be air-tight.

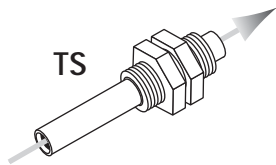

Use

The TS 11 series compensated spring systems are recommended for the horizontal handling of objects at different levels. The spring function also ensures that the gripping points are applied on the same plane when gripping with multiple suction pads.

- Internal spring.

Materials

Spring	Stainless steel
Tubing	Zinc-plated steel
Slider	Brass

Characteristics

References	A (mm)	F1 (mm)	F2	C (stroke) (mm)	D (mm)	L (mm)	1 (mm)	2 (mm)	Spring force (N/mm)	Force at rest (N)	 (g)
TS11 7	M5	M5	1/8G	7	19	43	7	14	0.68	1.3	20
TS11 10	M5	M5	1/8G	10	22	49	7	14	0.45	1.8	22
TS11 20	M5	M5	1/8G	20	39	76	7	14	0.24	1.7	33
TS11 40	M5	M5	1/8G	40	64	121	7	14	0.13	1.6	50

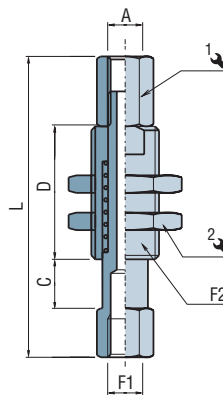

TS 11

Suction pad mounting

To choose the spring system corresponding to the reference of the suction pad, see the assembly diagrams on pages 2/15 to 2/21.

The TS 11 series spring system can be fitted on all suction pads in group 1 (VP, VSA, VS Ø5 to 25mm) for IM21 and on suction pads in series VPG 5 to 20.

For all orders, please specify:

The reference in the characteristics table

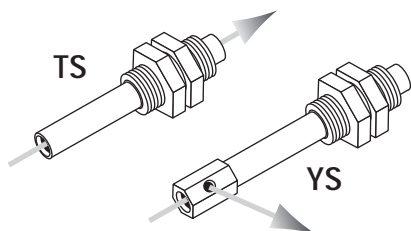

Use

TS and YS series compensated spring systems are recommended for the horizontal handling of parts at different levels. The spring function also ensures that the gripping points are applied on the same plane when gripping with multiple suction pads.

Materials

Spring	Stainless steel
Tubing	Zinc-plated steel
Slider	Brass

Characteristics

Models	TS1				TS2				TS3				TS1.20 LG		YS1			
Stroke (mm)	05	10	20	30	10	30	50	70	10	30	50	70	20	5	10	20	30	
L (mm)	29	39	59	79	48	88	128	168	48	88	128	168	59	29	39	59	79	
Spring force (N/mm)	0.36	0.15	0.07	0.045	0.9	0.2	0.115	0.08	0.9	0.2	0.115	0.08	0.07	0.36	0.15	0.07	0.045	
Force at rest (FR)	1.00	1.70	1.45	2	8.1	4.2	4.5	4.5	5.1	4.2	4.5	4.5	1.45	1.00	1.70	1.45	2	

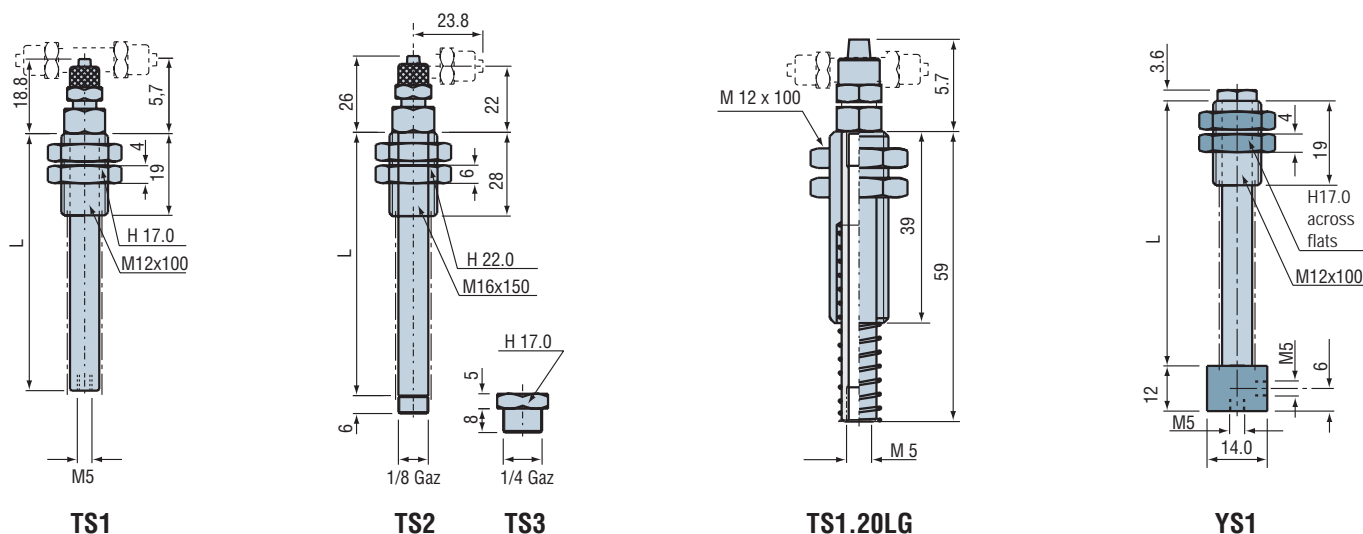

Advantage of the TS 120 LG

The adjustment height is twice that of the standard TS1 spring system and its spring is protected.

Suction pad mounting

To choose the spring system corresponding to the reference of the suction pad, see the assembly diagrams on pages 2/15 to 2/21.

For all orders, please specify:

Model + Spring stroke + Fitting

1: Model	2: Spring stroke	3: Fittings (for TS series)
TS1	05 - 10 - 20 - 30	TS1, TS2, TS3
TS2	10 - 30 - 50 - 70	TS2, TS3
TS3		
YS1		
D46	Straight 4 x 6	TS1, TS2, TS3
D68	Straight 6 x 8	TS2, TS3
C46	Elbow 4 x 6	TS1, TS2, TS3
C68	Elbow 6 x 8	TS2, TS3
T46 ⁽¹⁾	T-shape 4 x 6	TS1
N ⁽²⁾	Without fitting	

(1) versions T46 and T68 on request for TS2 and TS3.
 (2) For TS1 model, vacuum connection M5F and for models TS2 and TS3 vacuum connection M 1/8G

E.g. **TS3 50 C46**
 (TS3 spring system, Spring stroke 50mm, elbow fitting 4 x 6)

Characteristics

Models	TS4 50	TS5 60
Stroke (mm)	45	60
L (mm)	196	234
Spring force (N/mm)	0.47	1.23
Force at rest (FR)	4	0

Materials

Spring	Stainless steel
Tubing	Zinc-plated steel
Slider	Brass

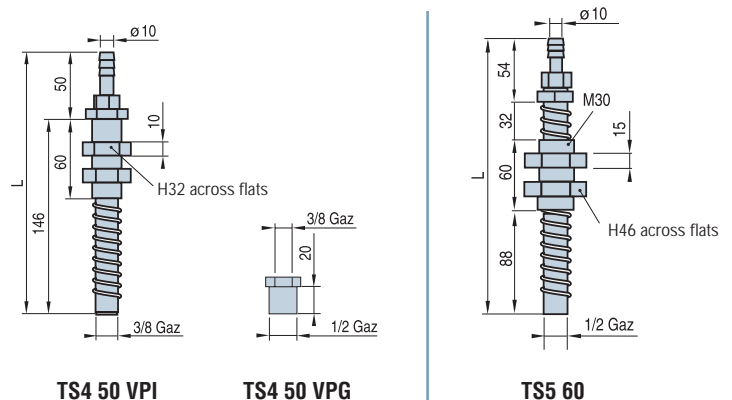

RSC series

Systems with 4 compensated springs

Materials

Spring	Stainless steel
Damper	Stainless steel
Studs	A 60
Colour	Yellow RAL 1023

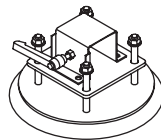

Use

The system of 4 compensated springs is particularly recommended for horizontal handling requiring large diameter suction pads. The upper stainless steel springs act as dampers for all vertical movements. They compensate for different levels between the suction pads. The system of 4 compensated springs mounted in a square gives the assembly a ball-joint effect.

Characteristics

Models	Max. load (N)	Stroke under traction (mm)	Vertical force (N)	Max. weight at half-way point (kg)	Ball-joint angle	Tube mounted (mm)	A (mm)	B (mm)	C (mm)	D (mm)	E	F (mm)	G (mm)	H (mm)	I (mm)	J (mm)	K (mm)	L (mm)
RSC1	2000	30	160	1	10 °	50	140	106	88	50	M8	M10	8	120	5	52	52	9
RSC2	4000	30	340	2.7	10 °	80	190	150	120	70	M12	M14	8	130	8	83	83	13

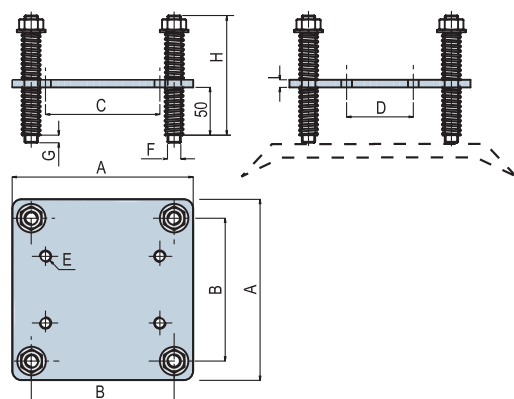

RSC option... VAC

Square tube mounting options (Tightening by indexable lever).

- RSC1 VAC on 50mm square tube.
- RSC2 VAC on 80mm square tube.

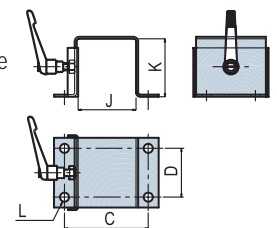

For all orders, please specify:

Model + Type + Tube mounting option

1: Model	2: Type	3: Tube-mounting option
RSC	1 max. 2000 N 2 max. 4000 N	VAC with tube-mounting option

Note:

- RSC1: for SPL 240 suction pads, 5085 steel suction pads, VA 250, VA 280 and VA 320.
- RSC2: for SPL 340 suction pads, 5150 steel suction pads, VA 350, VA 380 and VA 410.

E.g. RSC 2 VAC

(RSC type spring system, max. 4000 N with 80mm square tube mounting option).

TSOP - TSO series

Anti-rotation spring systems



Materials

Spring	Stainless steel
Tubing	Anodized aluminum
Slider	Nickel-plated steel

Use

The TSOP and TSO series spring systems are anti-rotation spring systems. They are used for horizontal handling of parts at different levels. The anti-rotation function ensures that objects are always gripped in the same position.

The TSOP range is designed for applications requiring very precise handling.

- The hexagonal rod prevents the suction pad from rotating.
- Internal spring.

Characteristics - TSOP series

References	A (mm)	F1 (mm)	F2	C (stroke) (mm)	D (mm)	L (mm)	1 (mm)	2 (mm)	Spring force (N/mm)	Force at rest (N)	(g)
TSOP 107	M5	M5	1/8 G	7	18	42	7	14	0.68	1.3	20
TSOP 110	M5	M5	1/8 G	10	22	49	7	14	0.45	1.8	22
TSOP 120	M5	M5	1/8 G	20	39	73.5	7	14	0.24	1.7	33
TSOP 140	M5	M5	1/8 G	40	64	118.5	7	14	0.13	1.6	50

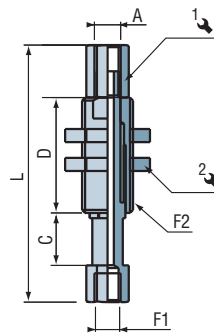

Characteristics - TSO series

References	A (mm)	F1 (mm)	F2	C (stroke) (mm)	B (mm)	D (mm)	L (mm)	1 (mm)	2 (mm)	Spring force (N/mm)	Force at rest (N)	(g)
TSO1 15 F	M5	M5	M12x1	15	10.5	27	53.5	12	15	0.111	1.664	18
TSO2 25 M	1/8G	1/8G	M16x1	25	15	40	90	15	19	0.2	4.007	41
TSO2 25 F	1/8G	1/8G	M16x1	25	15	40	82	15	19	0.2	4.007	39
TSO3 35 M	1/8G	1/4G	M20x1.5	35	18	60	123	18	24	0.25	5.49	93
TSO3 35 F	1/8G	1/4G	M20x1.5	35	18	60	123	18	24	0.25	5.49	88

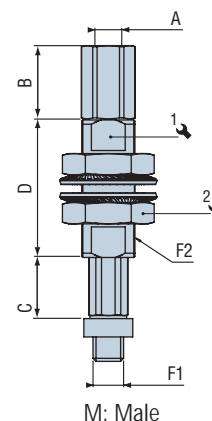
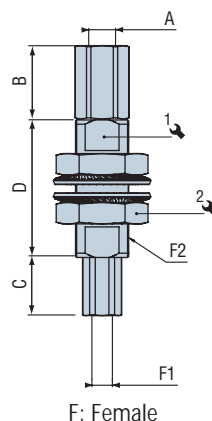

For all orders, please specify: The reference in the characteristics table

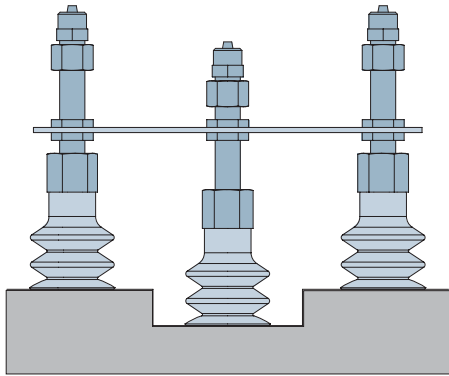

Use

The L series extensions are used for gripping on various levels from the same installation plate. These extensions are adjustable to different heights.

This system is especially useful for 2.5 bellows type suction pads, as height adjustment is made easier by the deflection of the suction pad.

Spring systems should be chosen instead, for flat suction pads with low deflection.

Materials

Threaded rod and nut Brass

Screwed vacuum fitting Nickel-plated brass

Characteristics

Models	A ⁽¹⁾ (mm)			B (mm)	C (mm)	h (mm)	(mm)	Ød (mm)	ØL	D (mm)	P (mm)
1/8 Gas	22	42	52	25	19	3	14	6	1/8G	-	-
1/4 Gas	19	49	69	29	24	4	19	9	1/4G	-	-
3/8 Gas F	19	49	69	20.5	-	4	23	3/8G	3/8G	19	22

(1) Other lengths available on request for a minimum quantity of 10 pieces.

1/4G - 1/8G

Straight

Elbow

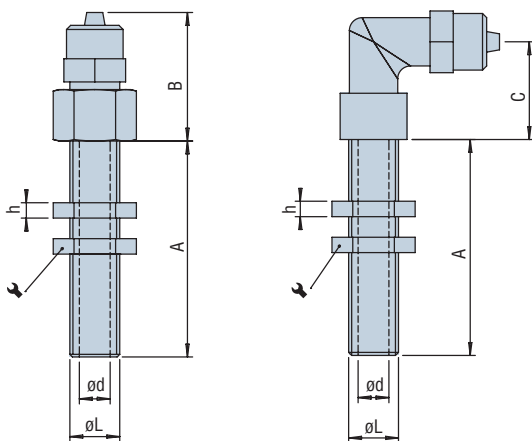

F3/8G

Straight 6x8

Elbow 6x8

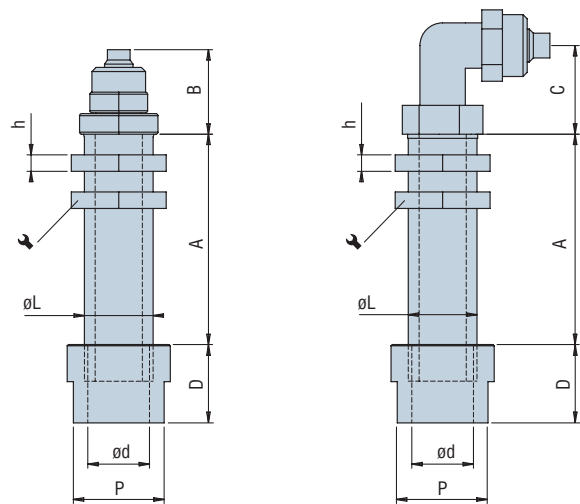

F3/8G extensions are compatible with the High Performance C series range of suction pads (see pages 2/11 to 2/13).

For all orders, please specify:

Model + Thread + Adjustable stroke + Fitting + F (for 3/8 Gas)

1: Model	2: Thread		3: Adjustable stroke		4: Fittings		5: F for 3/8 Gas
L	18	1/8 Gas	22 - 42 - 52	(1/8 Gas)	D46	Straight 4 x 6	
	14	1/4 Gas	19 - 49 - 69	(1/4 Gas)	D68	Straight 6 x 8	
	38	3/8 Gas		(3/8 Gas)	C46	Elbow 4 x 6	
					C68	Elbow 6 x 8	
					N	Without fitting	

On request

Possibility of T-shaped coupling. Please consult us.

E.g. L 14 49 C68

(L series extension, 1/4 Gas thread, Adjustable stroke 49, elbow fitting 6 x 8)

Miscellaneous gripping

Principle

In many cases when using a multi-suction pad installation, some of the pads will not be covered by the product(s) to be handled.

This leads to a high risk of reduced grip from the covered suction pads, or may even prevent them gripping at all.

E.g.

■ Gripping of panels, sheet metal, etc. in a wide variety of sizes by a lifting beam equipped with suction pads.

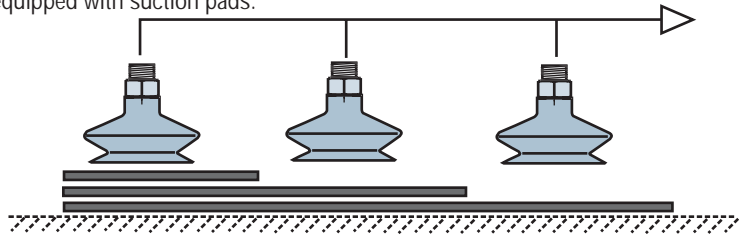

■ Uncertain position of the object(s).

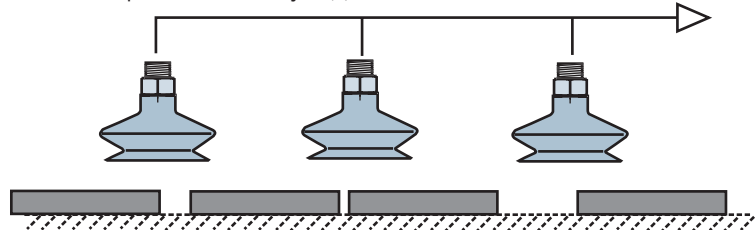

■ Gripping of several objects at once, some of which may be missing.

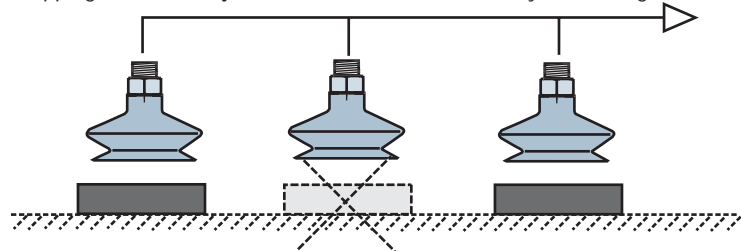

Solutions

■ Independent ejector

Mounting an ejector for each suction pad guarantees the installation will operate perfectly even if one or more suction pads are not covered.

COVAL answer to this problem is the VR, GVA and CIL series micro-ejectors.

For further information, see chapter 7.

■ Nozzle fittings

The nozzle fittings are incorporated inside the suction pad fitting, thus reducing the leakage when the pad is not covered by an object.

This technical solution is particularly suitable for vacuum chambers.

To establish the diameter of the nozzle, COVAL has developed a specific CAD.

■ Mechanical feelers or automatic shut-off valves

See previous pages. COVAL offers four solutions depending on the application, with their advantages and disadvantages.

Suction pad nozzle fittings

Groups 1 and 2



Use

This fittings are designed for installations with a large number of suction pads connected to the same vacuum generator (vacuum chamber technology), in particular for cases where there may be objects missing from the layer of objects to be handled. Using nozzle fittings reduces the loss of flow and therefore optimizes the size of the vacuum generator.

Caution, do not use this type of fitting for applications in a dusty environment.

5

IM60

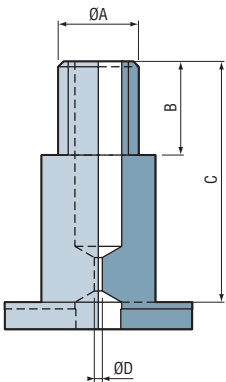

IM21 - IM22

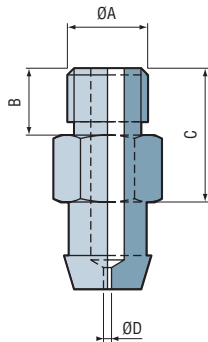

Characteristics

Model	ØA (mm)	ØD (mm)	B (mm)	C (mm)
IM60 SP335	M6	0.6	7	18
IM60 SP387	M6	1.2	7	18
IM60 SP461	M6	0.9	7	18
IM60 SP483	M6	1	7	18
IM60 SP510	M6	1.7	7	18
IM21 SP058	M5	0.45	4.5	9.5
IM21 SP094	M5	0.6	4.5	9.5
IM22 SP464	M6	0.6	5	10
IM60 SP511	M6	2.5	7	18

Maximum suction per nozzle diameter

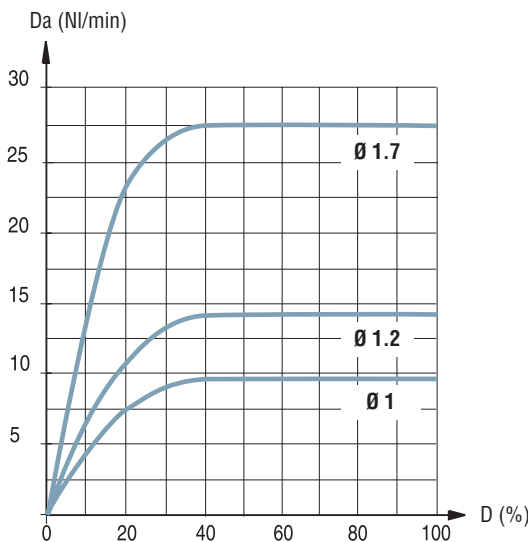
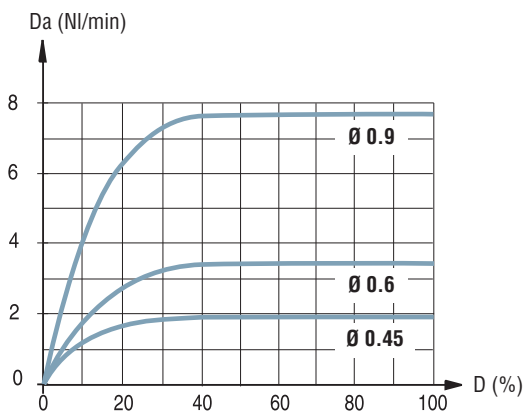

Da = Suction rate
D = Vacuum

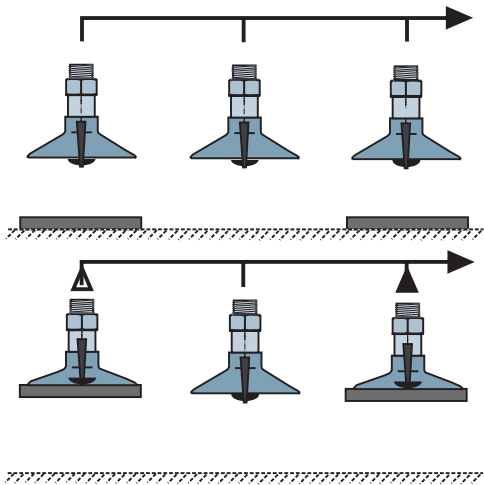

Use

The PMG2 series mechanical feelers are mounted on VP series diameter 30 to 60mm flat suction pads in all types of material (group 2 suction pads). The mechanical feeler protrudes beyond the suction pad, thus blocking the route for the vacuum. The feeler is actuated by the object, causing it to open and free the route for the vacuum.

Materials

Body Nickel-plated brass
Spring Stainless steel
Feeler Delrin brass

Characteristics

	VP 30	VP 35	VP 40	VP 50	VP 60
d (mm)	3.9	2.9	2.9	0.9	0.9
H (mm)	19	20	20	22	22

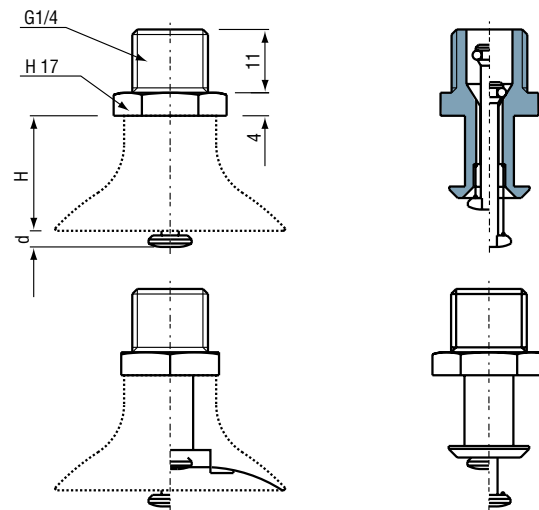

Advantages

- Simple to install and operate.
- Very efficient air-tightness for non-covered suction pads.
- Little risk of marking delicate objects, as the feeler has a rounded surface.

Accessories

Mounting on spring or ball-joint systems (see chapter 5).

Leakage rate

No leakage if all the suction pads are correctly placed. This represents substantial savings in power with regard to the vacuum source: Pneumatic ejector or electric vacuum pumps.

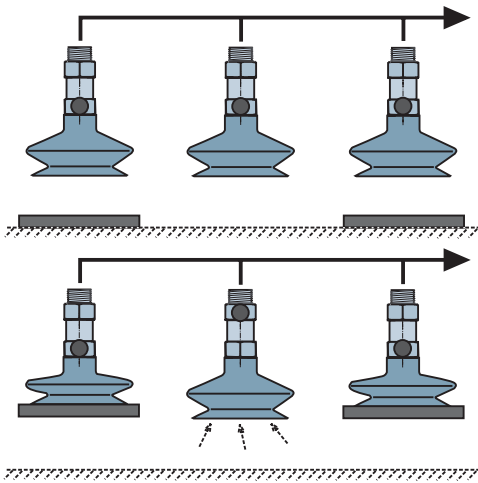

Use

With a centralized vacuum and no object under the suction pad, the suction causes the valve to close the vacuum inlet.

Advice

During release, carry out blow-off with compressed air in order to make it easier to free parts and to clean the valves.

Advantages

- Easy to install.
- Can be used with all shapes of suction pad.

Disadvantages

- Preferably used in a vertical position.
- Constant minimum leakage on uncovered suction pads.

5

Materials

PBA M5 ... 14 reg Aluminum
PBA M12 I Stainless steel

PBA M12I

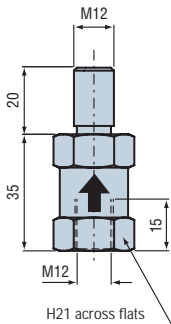

PBA 14 reg series adjustable shut-off valve

The adjustable shut-off valve allows you to adjust the leakage very precisely in relation to the internal volume of the suction pad for fast gripping.

Leakage rate

By design this valve has a permanent leakage if there is no object present, in order to operate correctly.

To calculate the flow needed from the vacuum source, take into account leakage (per object) at -0.6 bars of:

PBA M5: 0.22m ³ /h	PBA 38: 1.4m ³ /h
PBA 18: 0.43m ³ /h	PBA 12: 1.4m ³ /h
PBA 14: 0.47m ³ /h	PBA 14 reg: 0.2 to 4.3m ³ /h

PBA M5

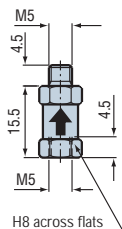

PBA 18

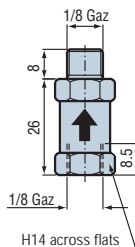

PBA 14

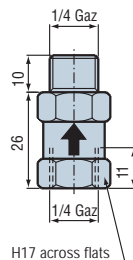

PBA 38

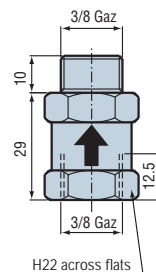

PBA 12

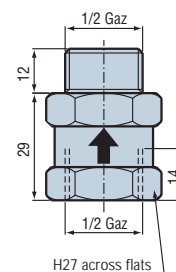

PBA 14 REG

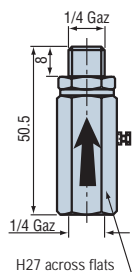

Please consult us for the old SV 14 and SV 18 series.

Accessories

Mounting on spring systems(see chapter 5).

Interchangeability

The PBA series is fully interchangeable with the old SVK or SV 14 reg series.

PBP series

Shut-off valves for porous products



Use

The PBP series leak sensing valve is suitable for miscellaneous gripping of very porous products such as cardboard and particle board, etc. The permanent leakage of the PBA series valve is not great enough to compensate for the porosity of the cardboard. The leak sensing valve is also recommended for very dusty objects such as wood. Please consult us to calculate the flow needed from the vacuum source, depending on the porosity of the load to be handled.

Characteristics

Models	Adaptable suction pads	 (g)	Flow ⁽¹⁾ (bar)	
			-0.3	-0.6
PBP VP 30	VP 30... 60 - VSA 33...63 - VS 32... 62	8	2.3	3.3
PBP VP 75	VP 75, 95 - VSA 78 - VS 88	18	2.3	3.3
PBP VPG 60	VPG 60, 80, 95	8	2.3	3.3

(1) Suction flow in m³/h per valve.

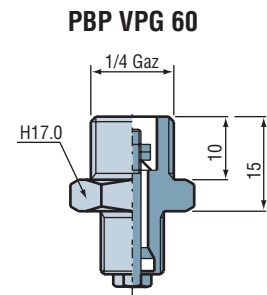
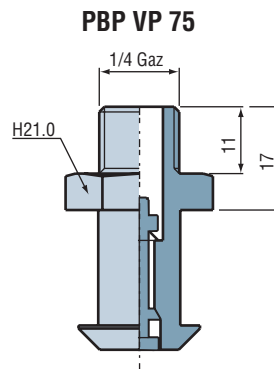
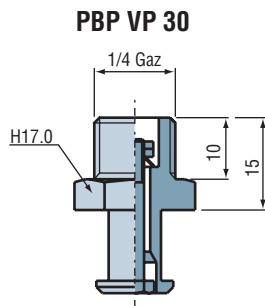

5

PBE series

Shut-off valves for air-tight products



Feature

The lack of leakage means that the suction pads must be placed on the object(s) to be handled before turning on the vacuum.

The suction pads must be pressed onto the object(s) to be gripped to reduce the internal volume and avoid premature closure of the valve.

Use

PBE series sensor valves are completely air-tight if no object is present, resulting in substantial savings at the vacuum source.

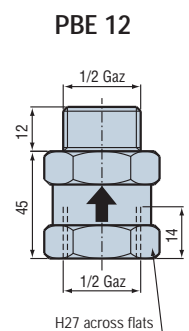
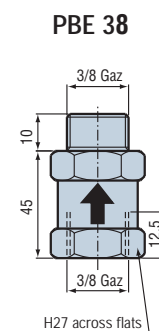
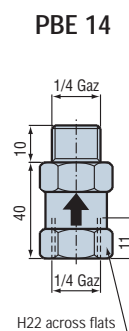
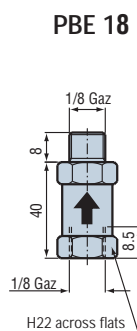
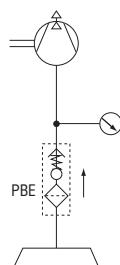

IMUKGL, IMU series

Axial ball-joints



Use

IMU and IMUKGL series ball-joints are recommended for gripping angled or rotating products.

Fitted on a flat suction pad, they transmit more force than a bellows-type suction pad.

Model IMU 14 M10M is designed to be fitted on suction pads in series VPG60 to 95.

Materials

Ball-joint Zinc-plated steel and brass

Seal Nitrile (NBR)

Characteristics

Models	C2 (mm)	Ø D (mm)	C (mm)	G	G1	E (mm)	E2 (mm)	H (mm)	FA ⁽¹⁾ (N)	 (g)
IMUKGL 18	8.5	2	7	1/8G	1/8G	14	14	26.5	150	26
IMUKGL 14	12	3.5	10	1/4G	1/4G	19	19	37.5	750	67
IMUKGL 12	14	4	12	1/2G	1/2G	24	24	40	1250	116
IMUKGL M10	12	3.5	10	1/4G	M10x125	19	19	37.5	750	67

(1) The axial force of the ball-joint (maximum permissible load) in daN including a safety factor of 2.

IMU KGL

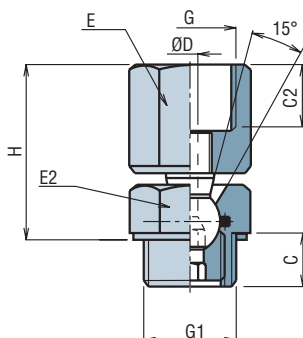

For all orders, please specify:

Model + suction pad fitting

1: Model	2: Suction pad fitting	
IMU	KGL 18	1/8 Gas
	KGL 14	1/4 Gas
	KGL 12	1/2 Gas
	KGL M10	M10x125

Accessories

IMU KGL series ball-joints are designed for the TS 2-3 series spring systems, see page 5/2.

E.g. IMU KGL 14
(IMU axial ball-joint, 1/4 Gas suction pad fitting)



Materials

Valve	Nitrile (NBR)
Body	Anodized aluminum
Filter	Stainless steel screen 200 μ

Use

The CSP series safety valve is a useful safety device. In the event of loss of vacuum or emergency stop it maintains the vacuum in the suction pad. Release is obtained by connecting the ancillary coupling to the pressure.

Mounting

- One safety valve per suction pad.
- Use a T version vacuum generator, 75% vacuum. Blow-off pressure, minimum 5 bar.

Characteristics

Models	G gas	ØD (mm)	F (mm)	L (mm)	J (mm)	H (mm)
CSP 14	1/4 G	4	25	33	12.8	21

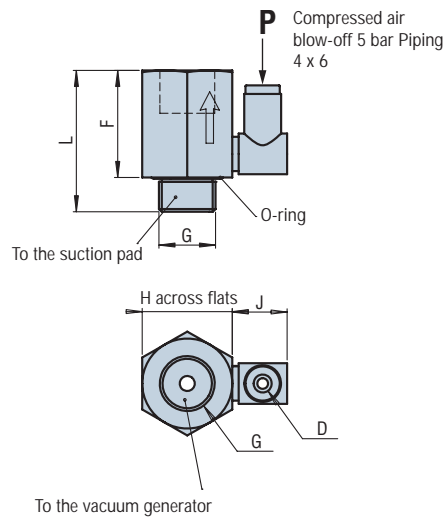
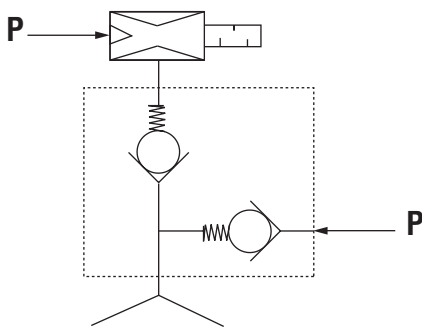



Branch-specific applications

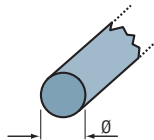
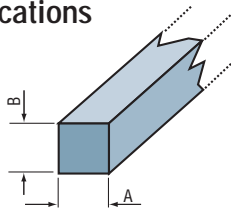

Nitrile foam strip: 10m roll

Mounting

Mounting with contact adhesive or flush-mounted at a depth adapted to the height and potential flush-mounting of the seal for the vacuum: 50% to 70% of the new height.

Support

- All supports, particularly steel, aluminum, etc.
- Closed cells.
- Closed Tube of neoprene adhesive (120 ml): ref. 095.99.006.

Ref.	A (mm)	B (mm)	Ø (mm)
BM 8	-	-	8
BM 205	20	5	-
BM 1510	15	10	-
BM 1010	10	10	-
BM1515	15	15	-
BM 2020	20	20	-
BM 3030	30	30	-
BM 5050	50	50	-

5

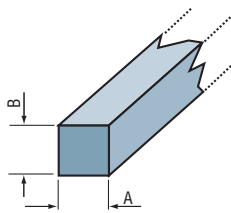

Silicone Foam Strip

- Heat resistant: 160°C.
- Do not use on parts before painting.
- Closed cells.

Ref.	A (mm)	B (mm)
BM 210 SI	10	2
BM 513 SI	13	5
BM SI 3030	30	30

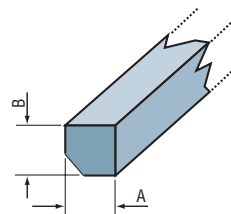

Nitrile bevelled foam strip: 10m roll

- The beveling facilitates gripping of products with uneven surfaces.
- Closed cells.
- Contact adhesive reference: BOSTIK 1400 (Neoprene adhesive)

Ref.	A (mm)	B (mm)
BM 2020 SPTR	20	20
BM 3020 SPTR	20	30
BM 3030 SPTR	30	30

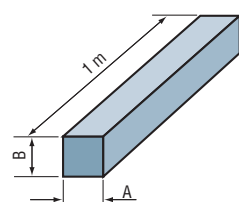

Natural Rubber Foam Strips: Length 1m

- Flush-mounting.
- Use with turbine (strong suction) for gripping products with very uneven surfaces, such as slabs of washed gravel slabs.
- Open cells.
- Contact adhesive reference: BOSTIK 1400 (Neoprene adhesive)

Ref.	A (mm)	B (mm)
BMS 3025	30	25

General points	p. 6/2
Choosing a vacuum pump	p. 6/3
Comparison	p. 6/4 and 6/5
Vacuum pump range	p. 6/6 to 6/8
Time to create vacuum	p. 6/9 and 6/10
Vacuum pump weight	p. 6/10

General points

What is vacuum?

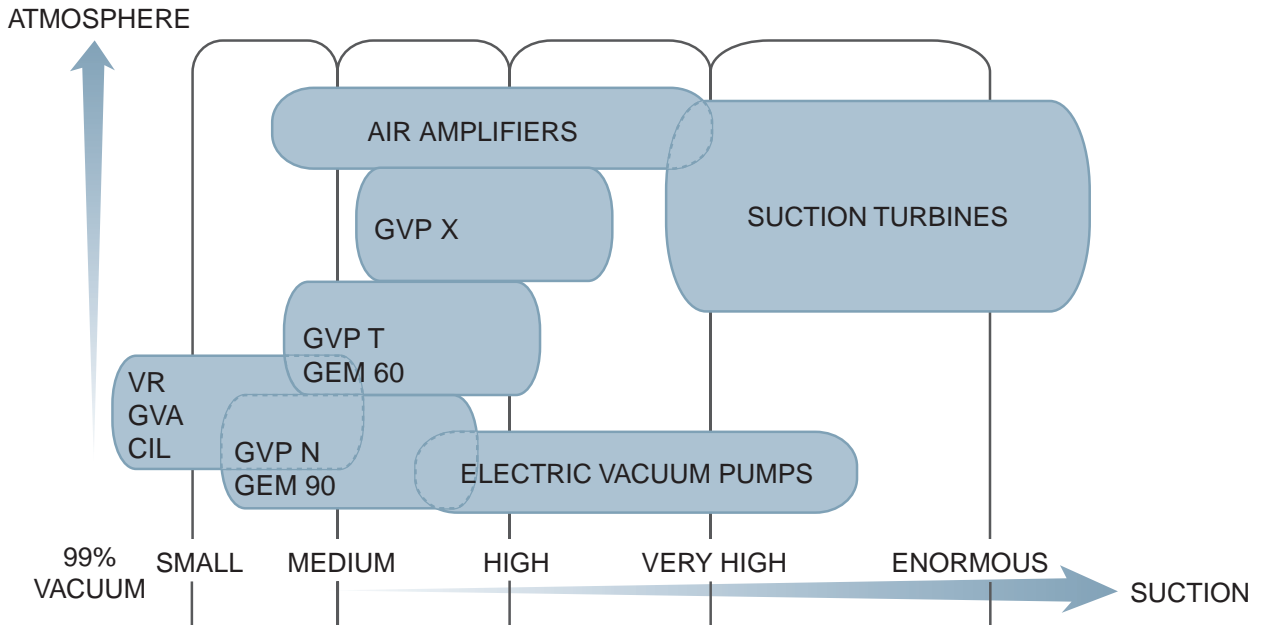

6

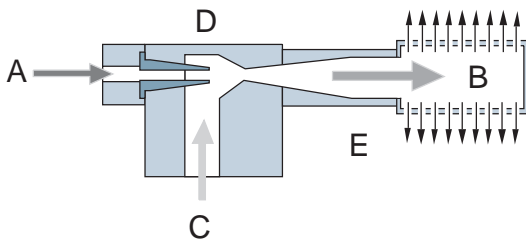

How a venturi works

The COVAL vacuum pump works on the Venturi principle. The filtered, non-lubricated compressed air in A is blown across nozzle D and speeds up. It then goes into mixer E and finally escapes through silencer B. The vacuum is caused by the pressure drop in the chamber around nozzle D. The air sucked out (C) follows the same route to finish in the silencer-B

Pressure unit conversion

Units	Bar 10 N/cm ² = 100 kPa	Atm kp/cm ²	Torr mm of Hg
Bar = 10 N/cm ² = 100 kPa		0.986923	750.0617
Atm = kp/cm ²	1.01325	1	760
Torr = mm of Hg	0.0013332	0.001316	1

Conversion according to the percentage of vacuum

%	Bar 10 N/cm ² = 100 kPa	Atm kp/cm ²	mm of water column
10%	-0.101	-0.103	1000
20%	-0.203	-0.207	2000
30%	-0.304	-0.310	3000
40%	-0.405	-0.413	4000
50%	-0.507	-0.517	5000
60%	-0.608	-0.620	6000
70%	-0.709	-0.723	7000
80%	-0.811	-0.827	8000
90%	-0.912	-0.930	9000

Choosing a vacuum pump

The job of the vacuum pump is to generate a relative vacuum within a capacity. For vacuum handling, this capacity generally consists of:

- the internal volume of the suction pads to be emptied,
- the volume of the network (piping).



Gripping air-tight and porous objects

■ air-tight objects

This is the only capacity to be taken into consideration.

The choice of vacuum pump will be made according to the time to create the vacuum corresponding to the function.

The maximum rate of vacuum it is possible to attain. It is useful to take the 90 % vacuums, (version N).

■ porous objects

In this case it will not be possible to empty the capacity. The leakage rate from the suction pad network will therefore be taken into account.

The vacuum pump adapted to this type of handling is therefore a vacuum pump for which the flow will be significantly greater than the leakage in order to create sufficient pressure drop in the suction pads.

High flow rate will be chosen in preference to a high vacuum, 75 % vacuum (version T) or 50 % vacuum (version X) for very porous objects such as light cardboard, or foam, etc.

Calculating the leakage rate

Apply a suction pad with a diameter suited to the object to be gripped.

Fit out a vacuum pump (for which the characteristics are known) with a pressure gauge and a vacuum gauge. Feed the vacuum pump with the optimal pressure (e.g. 5 bar).

Apply the suction pad to the surface to be tested.

Three possible cases can arise :

- The vacuum gauge indicates the maximum vacuum achieved for this type of gauge: the object is air-tight.
- The vacuum gauge does not measure any vacuum: choose a more efficient vacuum pump as the leakage rate is higher than the maximum vacuum pump flow.

- The vacuum gauge displays a vacuum value, e.g. -300 mb (30 % vacuum), refer to the vacuum pump curve. Read the flow corresponding to -300mb (e.g. 75 NI/minute)

The leakage rate is 75 NI/minute for the surface of the suction pad used at -300mb. Using this data, calculate the forces to be applied to handle the object:

At -300mb the theoretical force of the suction pad is: $F = S \times 0.3$ with:

S = surface of the suction pad in cm²F in DaN. To grip the object safely, (factor of 2 for horizontal gripping and 4 for vertical gripping), the different characteristics of the vacuum pumps must be exploited.

Things to remember

"An installation must breath properly".

The throughput for a machine includes:

- gripping time,
- transfer time,
- release time.

Study of efficient vacuum handling should ensure the release of the object is processed correctly, as this is often the most difficult point to resolve.

- place vacuum pump as close as possible to the suction pads,
- choose suction pads with the smallest possible internal volume,
- identify suitable sizes of piping and fittings to reduce pressure losses.

Comparison

Comparison of vacuum pumps and air amplifiers

Air amplifier



Optimal usage zone: 0 to 12 % vacuum.

Maximum usage range: 0 to 15% vacuum.

Applications: TRANSPORT - DRYING - DEGASSING

Handling very porous, light-weight products: carpet, textiles, foam, etc

Transporting small objects: granules, grains of coffee, rice, paperclips, etc.

Smoke evacuation, degassing.

Types of vacuum pumps

■ Version X, 50% vacuum

Optimal usage zone: 13 to 40% vacuum.

Maximum usage range: 0 to 50% vacuum.

Use of vacuum pumps creating 50% vacuum implies a high suction flow in relation to the pressure drop.

■ Version T, 75% vacuum and N, 90 % vacuum

Optimal usage zone: 41 to 90 % vacuum.

Maximum usage range: 0 to 90 % vacuum.

The interest of the vacuum pump which can create a 90% vacuum is to generate a high vacuum and therefore a high force / surface ratio.

■ Applications: HANDLING - SUCTION - EMPTYING - DOSING

Handling porous, semi-porous and air-tight products.

Programmed operations.

Air and/or liquid dosing.

- With version N, 90% vacuum:

Create a localized vacuum. Rationalize use of the vacuum in the machine functions using suction pads.

- With version T, 75% vacuum:

Create a generalized vacuum in suction tables and chambers.

Ejectors are very often integrated into automated handling equipment.



Comments

The optimal usage zones recommended above are the most adapted to the different types of technology. However they are in no way restrictive or limiting.

The notes are valid for both COVAL product groups: air amplifiers and vacuum pumps and also apply to all products using the same technology, whatever their market name.

Note:

The following curves have been established using COVAL equipment :

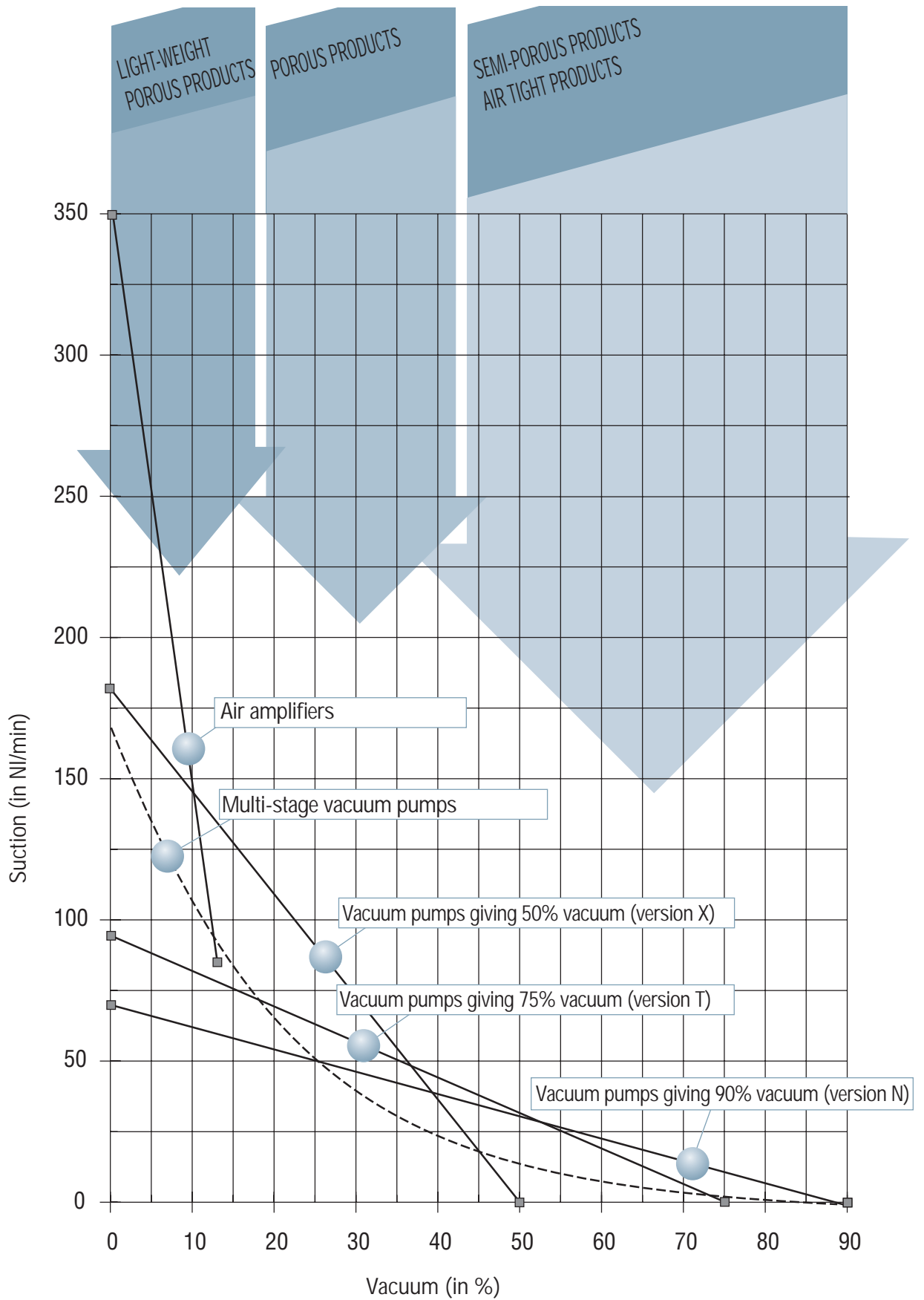

M 10 C air amplifier, GVP 15 XK, GVP 15 NS and GVP 15 TS vacuum pumps.

The values given are values for identical compressed air consumption and optimal characteristics of each of the vacuum generation procedures.









Coval vacuum pump range

Micro/mini-ejectors

Series	Technical Data	Advantages/Applications
CIL 	<ul style="list-style-type: none"> - 2 sizes - 3 nozzle Ø: 0.5 ; 0.7 ; 0.9mm - Suction flow: 9 NI/min to 31 NI/min - Optimum supply pressure: 5 bar - Weight between 7 and 13g - Hollow shaft or instantaneous fitting 	<ul style="list-style-type: none"> - In-line connection - Easily integrated - No clogging - Installation very close to the suction pads - Very flexible installation - Can be adapted to all branches
GVA 	<ul style="list-style-type: none"> - 2 nozzle Ø: 0.7 and 0.9mm - Suction flow: 12 to 18 NI/min - Optimum supply pressure: 5 bar - Weight 14g - Silencer option 	<ul style="list-style-type: none"> - Modular design thanks to the different options - Light - Very compact - Installation very close to the suction pads - No clogging - Silent operation - Can be adapted to all branches
VR 	<ul style="list-style-type: none"> - 2 models - Nozzle Ø: 0.5 ; 0.7 ; 0.9 ; 1.0 ; 1.2 ; 1.4mm - Suction flow: 7 to 64 NI/min - Optimum supply pressure: 5 bar - Weight between 20 and 45 g - Silencer option 	<ul style="list-style-type: none"> - Wide range - Very compact - Installed directly on the suction pads - Excellent mechanical resistance - Reduced gripping time - Blow-off option - Extended suction flow range - Silent operation - Can be adapted to all branches
GVR 	<ul style="list-style-type: none"> - 2 models - Nozzle Ø: 0.9 ; 1.0 ; 1.2 ; 1.4 mm - Suction flow: 21 to 64 NI/min - Optimum supply pressure: 5 bar - Weight 45 g - Integrated silencer 	<ul style="list-style-type: none"> - Very compact - Installed directly on the suction pads - Excellent mechanical resistance - No clogging - Reduced gripping time - Blow-off option - Extended suction flow range - Silent operation - Can be adapted to all branches
GV 	<ul style="list-style-type: none"> - 3 models - Nozzle Ø: 0.5 ; 1.0 ; 1.5 ; 2.0mm - Maximum suction flow: 165 NI/min - Optimum supply pressure: 5 bar - Two types of adjustable and pre-set vacuum switch - Solenoid valve and compressed air control options 	<ul style="list-style-type: none"> - Compact and light - Ideal for high throughput applications - Optimized vacuum adjustment thanks to two types of vacuum switch - Silent operation - No clogging





Coval vacuum pump range

Modular vacuum pumps

Series	Technical Data	Advantages/Applications
 <p>GVP</p>	<ul style="list-style-type: none"> - Simple vacuum pump - Nozzle Ø: 1.2 ; 1.5 ; 2.0 ; 2.5 ; 3mm - Suction flow: 150 to 450 NI/min - Optimum supply pressure: 4 to 5 bar - Integrated silencer 	<ul style="list-style-type: none"> - Modular design thanks to the different options - Compact - Optimized performance for handling all types of objects - Silent operation - No clogging - Can be adapted to all branches
 <p>GVC</p>	<ul style="list-style-type: none"> - Automatic blow-off capacity vacuum pump - Nozzle Ø: 1.2 ; 1.5mm - Suction flow: 63 to 95 NI/min - Optimum supply pressure: 4 to 5 bar - Integrated compressed air tank - Integrated silencer 	<ul style="list-style-type: none"> - Ideal for high throughput applications - Adjustable blow-off pressure - Compact - Optimized performance for handling all types of objects - Silent operation - No clogging - Can be adapted to all branches
 <p>GVCS</p>	<ul style="list-style-type: none"> - Vacuum pumps with electric vacuum control and automatic blow-off - Nozzle Ø: 1.2 ; 1.5mm - Suction flow: 63 to 95 NI/min - Optimum supply pressure: 4 to 5 bar - Integrated vacuum control - Integrated compressed air tank - Integrated silencer 	<ul style="list-style-type: none"> - Ideal for high throughput applications - Reduced wiring - Adjustable blow-off pressure - Gripping time divided by two in relation to multi-stage technology - Compact - Optimized performance for handling all types of objects - Silent operation - No clogging - Can be adapted to all branches
 <p>Electric GVPS</p>	<ul style="list-style-type: none"> - Vacuum pumps with electric vacuum control - Nozzle Ø: 1.2 ; 1.5 ; 2.0 ; 2.5 ; 3mm - Suction flow: 150 to 450 NI/min - Optimum supply pressure: 4 to 5 bar - Integrated electric vacuum control - Integrated silencer 	<ul style="list-style-type: none"> - Modular design thanks to the different options - Compact - Optimized performance for handling all types of objects - Silent operation - No clogging - Can be adapted to all branches
 <p>Electric GVPD</p>	<ul style="list-style-type: none"> - Vacuum pumps with electric vacuum control and blow-off - Nozzle Ø: 1.2 ; 1.5 ; 2.0 ; 2.5 ; 3mm - Suction flow: 150 to 450 NI/min - Optimum supply pressure: 4 to 5 bar - Integrated blow-off and vacuum control - Integrated silencer 	<ul style="list-style-type: none"> - Modular design thanks to the different options - Compact - Optimized performance for handling all types of objects - Silent operation - No clogging - Can be adapted to all branches - Adjustable blow-off flow
 <p>GVS</p>	<ul style="list-style-type: none"> - Safety vacuum pump with blow-off and electric vacuum control - Nozzle Ø: 1.2 ; 1.5 ; 2.0 ; 2.5 ; 3.0 mm - Optimum supply pressure: 4 to 5 bar - Two integrated check valves 	<ul style="list-style-type: none"> - Ideal for handling air-tight objects - Safety guaranteed by check valves - Optimal performance - Silent operation - No clogging

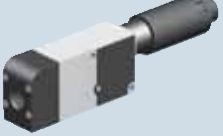
Coval vacuum pump range

Intelligent vacuum pumps

Series	Technical Data	Advantages/Applications
 <p>GEM</p>	<ul style="list-style-type: none"> - Integrated energy-saving vacuum pumps - Nozzle Ø 1.2 ; 1.5 ; 2.0 ; 2.5 ; 3mm - 2 levels of vacuum: 60% and 90% - All the functions required integrated in the product - Integrated pressure regulator - Integrated M12 connection (Plug &Play) 	<ul style="list-style-type: none"> - Coval's "all in one" innovative solution - Energy savings exceeding 50% - Noise levels reduced by up to 30dBa - Modular design thanks to the different options - Reduced wiring - Reduced installation time - No clogging - Optimized performance for handling all types of objects - Can be adapted to all branches
 <p>GEMP</p>	<ul style="list-style-type: none"> - Simple energy-saving vacuum pumps - Nozzle Ø 1.2 ; 1.5 ; 2.0 ; 2.5 ; 3mm - 2 levels of vacuum: 60% and 90% - Suction flow between 150 and 450 NI/min - Integrated pressure regulator - Integrated silencer 	<ul style="list-style-type: none"> - Very compact and light-weight - Ideal for all applications requiring an outside pressure regulator - Exceptional energy savings thanks to automatic pressure regulation at 4 bar - Optimal performances - Silent operation - No clogging
 <p>GVMAX</p>	<ul style="list-style-type: none"> - Self-regulating vacuum pumps (electric or pneumatic vacuum control and blow-off) - Two versions: electric or pneumatic - Nozzle Ø: 2.5 mm - Three levels of vacuum: 50%, 75% and 90% - Vacuum regulation function - Integrated vacuum solenoid valves and blow-off - 2 integrated check valves for pneumatic version and 1 for electric version - Integrated vacuum switch to adjust the vacuum threshold and hysteresis 	<ul style="list-style-type: none"> - Compact and light - Ideal for retaining air-tight objects in the automotive, plastics and sheet metal industries - Energy saved by the vacuum regulation function - Safety guaranteed in case of power failure - Optimal performances - Silent operation - No clogging
 <p>GVMAX V2/V2R</p>	<ul style="list-style-type: none"> - Special self-regulating vacuum pumps (electric vacuum control and blow-off) - Separate inlets and outlets - M12 connections - Nozzle Ø: 2.5 mm - Maximum vacuum level 90% - Integrated vacuum solenoid valves and blow-off - Integrated vacuum check-valve - Vacuum regulation function 	<ul style="list-style-type: none"> - Compact and light - Ideal for retaining air-tight objects in the automotive, plastics and sheet metal industries - Energy saved by the vacuum regulation function - Safety guaranteed in case of power failure - Optimal performances - Silent operation - No clogging
 <p>GVMAX V3</p>	<ul style="list-style-type: none"> - Special self-regulating vacuum pumps (electric vacuum control and blow-off) - Separate inlets and outlets - M12 connections - Nozzle Ø: 3 mm - Integral blow-off - Integrated pressure regulator - Maximum vacuum level 90% - Integrated vacuum solenoid valves and blow-off - Integrated vacuum check-valve - Vacuum regulation function 	<ul style="list-style-type: none"> - Compact and light - Ideal for retaining air-tight objects in the automotive, plastics and sheet metal industries - Energy saved by the vacuum regulation function - Safety guaranteed in case of power failure - Optimal performances - Silent operation - No clogging
 <p>GVE</p>	<ul style="list-style-type: none"> - Self-regulating vacuum pumps with pneumatic vacuum control - Nozzle Ø 1.2 ; 1.5 ; 2.0 ; 2.5 ; 3mm - Suction flow between 150 and 450 NI/min - 3 levels of vacuum: 45%, 75% and 90% - Pneumatic vacuum valve and integrated control - Integrated vacuum check-valve - Integrated vacuum switch for the vacuum threshold - Integrated silencer 	<ul style="list-style-type: none"> - Compact and light - Ideal for explosive environments and tank emptying applications - Optimized performance - Safety guaranteed by the vacuum retaining check valve - Energy saved by the vacuum regulation function - Silent operation - No clogging

Evacuation time

Evacuation time in seconds per liter

% vacuum	10	20	30	40	50	60	70	80	85
GV05N	1.07	2.3	3.73	5.45	7.55	10.48	14.74	24.31	
VR05	0.92	1.96	3.18	4.63	6.38	8.79	12.17	18.96	27.39
CIL05	0.92	1.96	3.18	4.63	6.38	8.79	12.17	18.96	27.39
GVA07	0.54	1.15	1.88	2.76	3.86	5.44	7.87	15.4	24.29
VR07	0.46	0.98	1.58	2.28	3.13	4.27	5.8	8.55	11.01
CIL07	0.46	0.98	1.58	2.28	3.13	4.27	5.8	8.55	11.01
GVA09	0.36	0.77	1.25	1.84	2.57	3.62	5.24	10.27	16.19
VR09	0.31	0.65	1.05	1.52	2.09	2.85	3.87	5.7	7.34
CIL09	0.31	0.65	1.05	1.52	2.09	2.85	3.87	5.7	7.34
VR10	0.24	0.51	0.82	1.18	1.62	2.21	3.01	4.43	5.71
GVR10	0.24	0.51	0.82	1.18	1.62	2.21	3.01	4.43	5.71
VR12	0.14	0.3	0.49	0.71	0.97	1.33	1.81	2.66	3.42
GVR12	0.14	0.3	0.49	0.71	0.97	1.33	1.81	2.66	3.42
VR14	0.1	0.21	0.34	0.5	0.68	0.93	1.27	1.85	2.44
GVR14	0.1	0.21	0.34	0.5	0.68	0.93	1.27	1.85	2.44
GVM3	0.13	0.27	0.44	0.65	0.91	1.24	1.77	2.9	
GV10N	0.24	0.51	0.82	1.18	1.62	2.21	3.01	4.43	5.71
GVP/S/D12N, GVS12N, GVMAX12N, GVE12N	0.14	0.3	0.49	0.71	0.97	1.33	1.81	2.66	3.42
GV15N	0.1	0.22	0.35	0.51	0.7	0.95	1.29	1.9	2.45
GVP/S/D15, GVS15N, GVMAX15N, GVE15N	0.09	0.20	0.32	0.46	0.63	0.85	1.16	1.71	2.20
GV20N	0.05	0.11	0.18	0.26	0.35	0.48	0.65	0.96	1.23
GVP/S/D20N, GVS20N, GVMAX20N, GVE20N	0.06	0.12	0.19	0.28	0.38	0.52	0.71	1.04	2.13
GVP/S/D25N, GVS25N, GVMAX25N, GVE25N	0.03	0.07	0.11	0.16	0.22	0.30	0.41	0.60	0.77
GVP/S/D30N, GVS30N, GVMAX30N, GVE30N	0.02	0.05	0.08	0.12	0.17	0.23	0.31	0.45	0.58

% vacuum	10	20	30	40	50	60	70
GVP/S/D12T, GVMAX12T, GVE12T	0.1	0.22	0.37	0.55	0.78	1.16	1.92
GVP/S/D15T, GVMAX15T, GVE15	0.07	0.15	0.24	0.36	0.52	0.77	1.27
GVP/S/D20T, GVMAX20T, GVE20	0.04	0.09	0.14	0.22	0.31	0.46	0.76
GVP/S/D25T, GVMAX25T, GVE25	0.03	0.06	0.1	0.14	0.21	0.3	0.5
GVP/S/D30T, GVMAX30T, GVE30	0.02	0.04	0.07	0.1	0.15	0.22	0.37

% vacuum	10	20	30	35	40	45
GV05X	0.74	1.66	2.89	3.69	4.71	6.12
GV10X	0.19	0.42	0.72	0.92	1.18	1.53
GVP/S/D12X, GVMAX12X, GVE12X	0.05	0.11	0.22	0.33	0.62	0.62
GV15X	0.07	0.16	0.27	0.35	0.45	0.58
GVP/S/D15X, GVMAX15X, GVE15X	0.04	0.09	0.15	0.2	0.27	0.39
GV20X	0.04	0.09	0.15	0.2	0.26	0.33
GVP/S/D20X, GVMAX20X, GVE20X	0.03	0.06	0.11	0.15	0.19	0.28
GVP/S/D25X, GVMAX25X, GVE25X	0.02	0.04	0.08	0.1	0.14	0.19
GVP/S/D30X, GVMAX30X, GVE30X	0.01	0.03	0.06	0.08	0.11	0.15

Evacuation time

Evacuation time in seconds per liter (cont.)

% vacuum	10	20	30	40	50	60	70	80	85
GEM60x12	0.09	0.2	0.35	0.55	0.9	-	-	-	-
GEM60x15	0.06	0.14	0.23	0.36	0.59	-	-	-	-
GEM60x20	0.04	0.08	0.13	0.21	0.34	-	-	-	-
GEM60x25	0.03	0.05	0.09	0.14	0.24	-	-	-	-
GEM60x30	0.01	0.04	0.07	0.10	0.17	-	-	-	-
GEM90x12	0.13	0.27	0.44	0.64	0.88	1.19	1.62	2.37	3.12
GEM90x15	0.09	0.18	0.29	0.42	0.58	0.79	1.08	1.59	2.08
GEM90x20	0.05	0.11	0.18	0.25	0.35	0.46	0.65	0.95	1.25
GEM90x25	0.03	0.07	0.11	0.16	0.22	0.3	0.41	0.59	0.78
GEM90x30	0.03	0.06	0.09	0.13	0.18	0.24	0.33	0.48	0.64

Note: evacuation time of GEMP = evacuation time of GEM.

Weight of micro/mini-ejectors in grams

Model	Nozzle size							
	0,5	0,7	0,9	1,0	1,2	1,4	1,5	2,0
CIL (Size 1)	7	9	-	-	-	-	-	-
CIL (Size 2)	11	12	13	-	-	-	-	-
VR	20.7	20.5	20.2	45.4	45.4	45.4	-	-
GVR	20.7	20.5	20.2	45.4	45.4	45.4	-	-
GVA	14.1	-	14.3	-	-	-	-	-
GV	80	-	-	80	-	-	140	350
GV.V	100	-	-	100	-	-	160	440
GV.VR	120	-	-	120	-	-	190	460

Weight of modular vacuum pumps in grams

Model	Nozzle size				
	1.0mm	1.5mm	2.0mm	2.5mm	3.0mm
GVP	100	110	160	180	265
GVPS	180	190	240	260	345
GVPS(New)	176,5	186,5	236,5	256,5	341,5
GVPD	270	280	330	340	425
GVPD(New)	208,5	218,5	268,5	278,5	363,5
GVC	170	180	-	-	-
GVCS	250	260	-	-	-
GVS	465,5	475,5	525,5	545,5	630,5
GVS (New)	403	413	463	483	568
GVMAXE	-	-	-	510	-
GVMAXP1	maximum weight 440				
GVMAXV2/ V2R	-	-	-	550	-
GVMAXV3	-	-	-	-	450
GVE	maximum weight 420				
GEM	maximum weight 250				
GEMP	maximum weight 265				

CIL



P_{7/2}

- 2 sizes
- 3 nozzle diameters: 0.5 ; 0.7 ; 0.9mm
- Suction rate: 9 NI/min to 31 NI/min
- Optimal supply pressure: 5 bar
- Weight between 7 and 13g
- Hollow shaft or push fittings

- In-line connection
- Easily integrated
- No clogging
- Installation very close to the suction pads
- Very flexible installation
- Can be adapted to all branches

GVA



P_{7/4}

- 2 nozzle Ø: 0.7 and 0.9mm
- Suction rate: 12 to 18 NI/min
- Optimal supply pressure: 5 bar
- Weight 14g
- Silencer option

- Modular design thanks to the different options
- Light
- Very compact
- Installation very close to the suction pads
- No clogging
- Silent operation
- Can be adapted to all branches

VR



P_{7/8}

- 2 models
- Nozzle Ø: 0.5 ; 0.7 ; 0.9 ; 1.0 ; 1.2 ; 1.4mm
- Suction rate: 7 to 64 NI/min
- Optimum supply pressure: 5 bar
- Weight between 20 and 45 g
- Silencer option

- Wide range
- Very compact
- Installed directly on the suction pads
- Excellent mechanical resistance
- Reduced gripping time
- Blow-off option
- Extended suction flow range
- Silent operation
- Can be adapted to all branches

GVR



P_{7/12}

- 2 models
- Nozzle Ø: 0.9 ; 1.0 ; 1.2 ; 1.4mm
- Suction rate: 21 to 64 NI/min
- Optimum supply pressure: 5 bar
- Weight 45g
- Integrated silencer

- Very compact
- Installed directly on the suction pads
- Excellent mechanical resistance
- No clogging
- Reduced gripping time
- Blow-off option
- Extended suction rate range
- Silent operation
- Can be adapted to all branches

GV



P_{7/14}

- 3 models
- Nozzle Ø: 0.5 ; 1.0 ; 1.5 ; 2.0mm
- Maximum suction rate: 165 NI/min
- Optimum supply pressure: 5 bar
- Two types of adjustable and pre-set vacuum switch
- Solenoid valve and compressed air control options

- Compact and light
- Optimized vacuum adjustment thanks to two types of vacuum switch
- Silent operation
- No clogging



Branch-specific applications

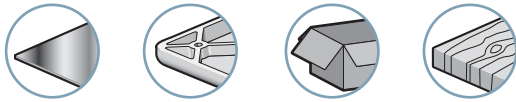

Flexible installation

Push fitting

Removable axial mounting directly on the pipe using push to connect fittings.

Available in two sizes

- For pipe calibrated 2.7 x 4 mm (size 1)
- For pipe calibrated 4 x 6 mm (size 2)



Permanent connection

Permanent axial mounting directly on the pipe using hollow shaft fittings. An economical, ultra-light solution.

Available in two sizes

- For pipe calibrated 2.7 x 4 mm (size 1)
- For pipe calibrated 4 x 6 mm (size 2)



Integrated fitting

M12 (size 1) or M14 (size 2) incorporated male thread allows the CIL in-line module to be fitted easily and securely.



Manifold mounting

M12 (size 1) or M14 (size 2) incorporated male thread allows several CIL in-line vacuum modules to be integrated into a machined block to feed several suction pads simply and economically from a single source of compressed air.



Description

Due to their light weight (from 7 to 13 g depending on the version) and small dimensions, the "just plug it in" CILs can be easily integrated into the compressed air network near the suction pads, even in the most inaccessible parts of the machine.

Use

COVAL advises using CIL in-line ejectors for handling electronic components and light-weight objects, feed systems, Pick and Place applications and separating systems for machining sheet metal or plastics.

Advantages

- Simple, efficient connection

Push fitting, hollow shaft fittings, M12 male or M14 male thread.

- Improved reliability

No moving mechanical parts.

- Silent operation

Nozzle-mixer combination resulting from new COVAL fluidics.

- Optimized performance

CILs are available in 3 nozzle diameters (0.5, 0.7 and 0.9mm) and 2 levels of vacuum (60 % and 90 %).

Characteristics

model	Ø nozzle (mm)	air consumed (NI/min)	air drawn in (NI/min)	
			CIL 60	CIL 90
CIL 05	0.5	9.5	9.5	7
CIL 07	0.7	18.5	18.5	13.7
CIL 09	0.9	30.5	30.5	22.6

Evacuation time in seconds per liter

% vacuum	10	20	30	40	50	60	70	80	85
CIL 05	0.92	1.96	3.18	4.63	6.38	8.79	12.17	18.96	27.39
CIL 07	0.46	0.98	1.58	2.28	3.13	4.27	5.8	8.55	11.01
CIL 09	0.31	0.65	1.05	1.52	2.09	2.85	3.87	5.7	7.34

Specifications

Supply non-lubricated filtered air, 5 microns (ISO standard 8573-1 class 4).

Optimal operating pressure 5 bar

Weight 7 to 13 g, depending on the model.

Materials PA6.6 15 % FV – 2017A

Operating temperature 0 to 60 °C / 14 to 140 °F.

Delivered with a zinc-plated steel fastening nut.

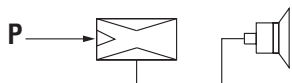

For all orders, please specify: Model+ Size + Vacuum level + X + Nozzle diameter + Fitting

1: Model	2: Size	3: Vacuum level	X	4: Nozzle diameter	5: Fitting
CIL	1 M12 male thread 2 M14 male thread	60 60 % 90 90 %	X	05 Ø 0.5mm 07 Ø 0.7mm 09 ⁽¹⁾ Ø 0.9mm	C Hollow shaft R Push to connect fitting

E.g. CIL 190 X 07 C

(CIL in-line vacuum module, size 1, maximum vacuum 90 %, nozzle diameter 0.7mm, hollow shaft fitting).

(1) only in size 2



Dimensions

(1) Push fitting
(2) Hollow shaft

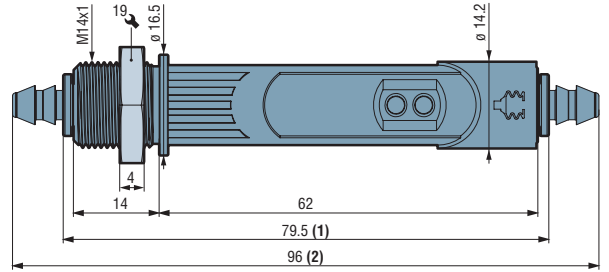
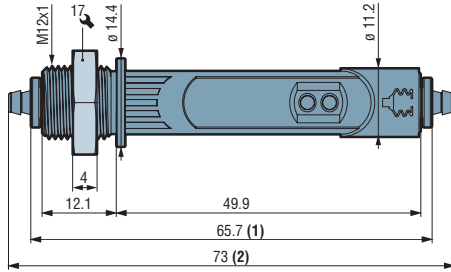

Advantages

- Can be adapted to all branches
- In-line connection
- Installation very close to the suction pads
- No clogging
- Very flexible installation
- Silent operation

Curves

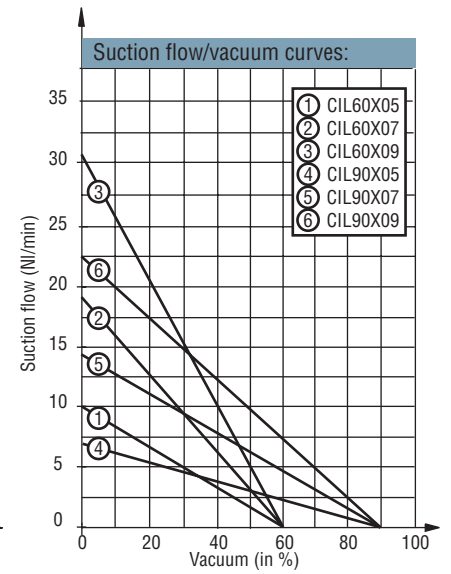
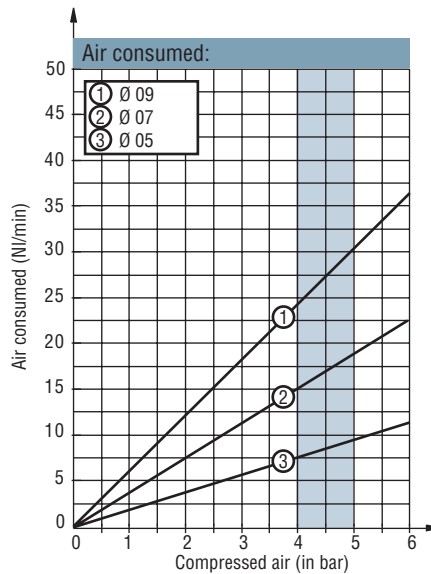
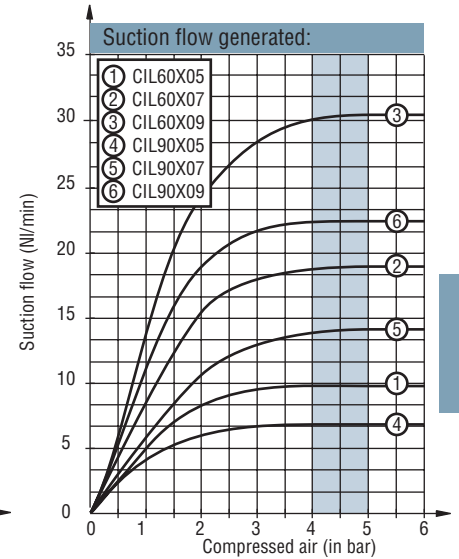
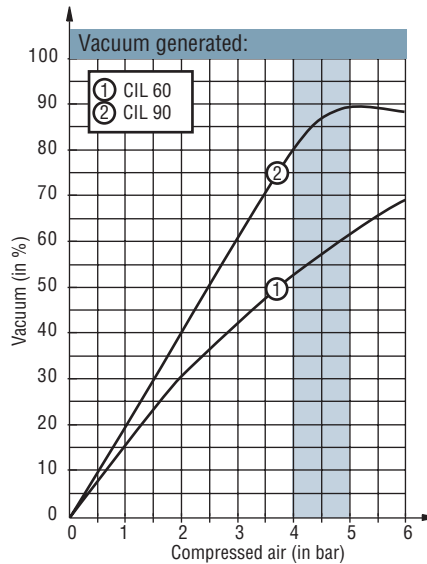



Branch-specific applications

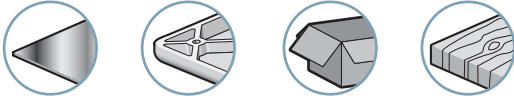

Description

GVA series in-line ejectors are particularly adapted to automation thanks to their low weight and very short response time. Their thermoplastic design retains high-performance mechanical characteristics and provides economical solutions for vacuum handling.

Advantages

- Can be adapted to all branches
- Ideal for Pick and Place applications
- Modular design thanks to the different options
- Reduced gripping time
- Light and compact
- Installation very close to the suction pads
- No clogging
- Silent operation

Characteristics

model	Ø nozzle (mm)	air consumed (NI/min)	maximum-vacuum(%)	air drawn in (NI/min)	at air pressure (bar)
GVA 07 (blue)	0.7	21	82	12	5
GVA 09 (grey)	0.9	36	82	18	5

Evacuation time in seconds per liter

% vacuum	10	20	30	40	50	60	70	80	85
GVA07	0.54	1.15	1.88	2.76	3.86	5.44	7.87	15.4	24.29
GVA09	0.36	0.77	1.25	1.84	2.57	3.62	5.24	10.27	16.19

Specifications

Supply	Non-lubricated filtered air, pressure 2 to 6 bar
Optimum operating pressure	5 bar
Weight	15g
Material	Polyoxymethylene (POM) blue for GVA 07 grey for GVA 09
Temperature	-10 to 80 °C / 14 to 186°F
M5 fitting	Brass - On option: stainless steel

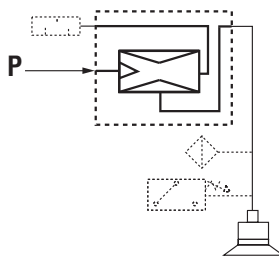

Additional information

- Mounting of GVASIL or GVASPO silencers
- GVAC exhaust manifold
- GVAV vacuum data plug
- GVAG manifold installation
- GVA F18 vacuum filter
- Clip fitting ref. GVA.F, delivered in batches of 5
- Option see pages 7/6 to 7/7.

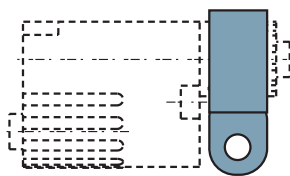

Clip ref. : GVA.F

For all orders, please specify:

Model + nozzle diameter + Fitting + Silencer

1: Model	2: Nozzle diameter	3: Fitting	4: Silencer
GVA	07 Ø 0.7mm (blue) 09 Ø 0.9mm (grey)	M5 M5 female, C.A. and vacuum M5I M5 Female, A.C and Vacuum in Stainless steel 24 Tube 2.7/4 mm, C.A. and vacuum 244 Tube 2.7/4 mm, C.A., dia. 4 on vacuum	- Without silencer S GVASIL SPO GVASPO

E.g. GVA 07 M5 S

(GVA series in-line ejector, nozzle diameter 0.7 mm, M5 female fitting, C.A. and vacuum with GVASIL silencer).



Dimensions

- (1) Reference V : Vacuum outlet
Fitting M5 F. depth. 6mm or
Push fitting for tube \varnothing 4mm or
Male fitting \varnothing 4mm length 22.5 mm
- (2) GVASIL or GVASPO
- (3) Vacuum
- (4) GVASIL dimensions
- (5) Venturi exhaust
- (6) C.A. inlet, 5 bar
Fitting M5 F. depth. 6mm or
Push fitting \varnothing 4mm
Reference P : Pressure

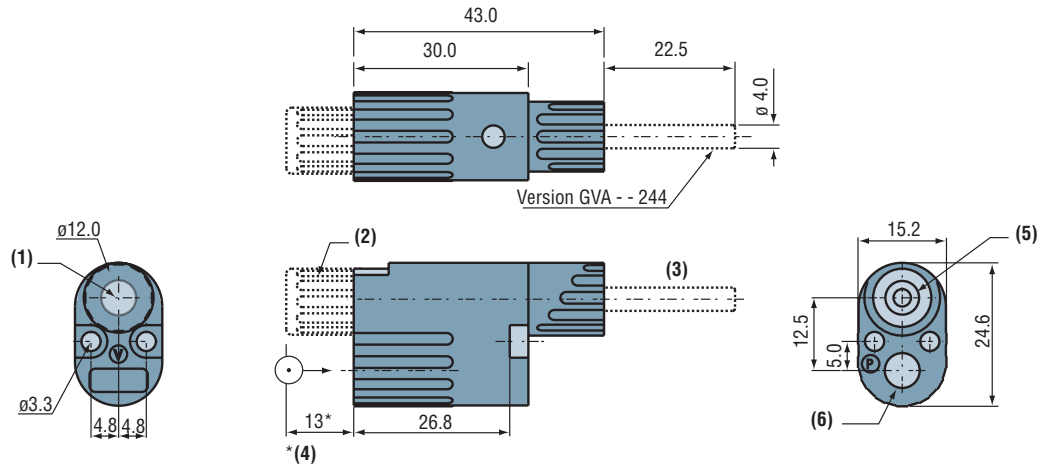

Curves

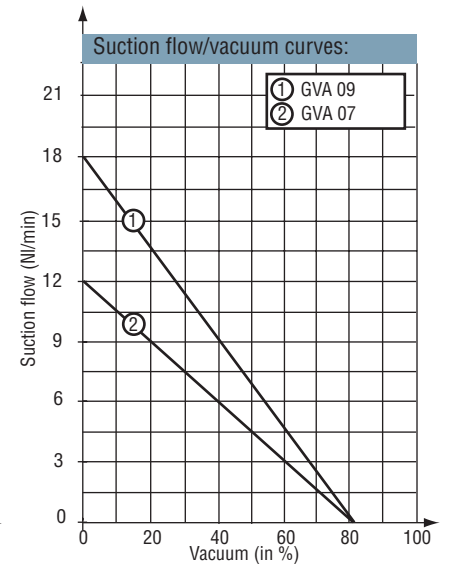
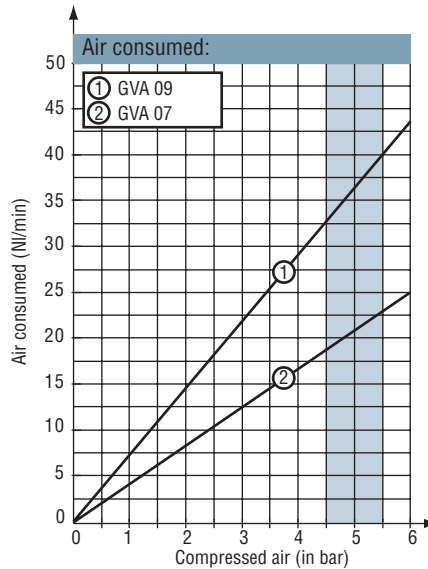
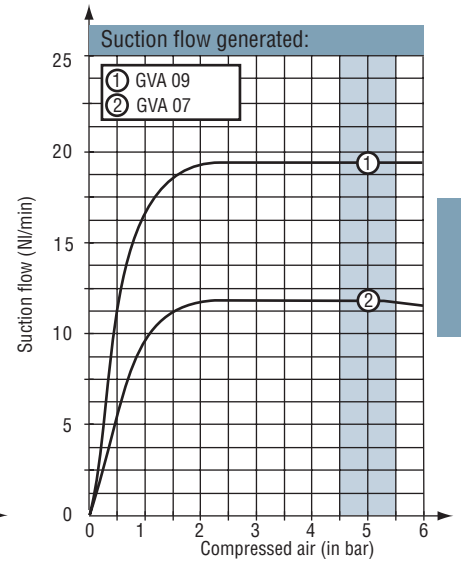
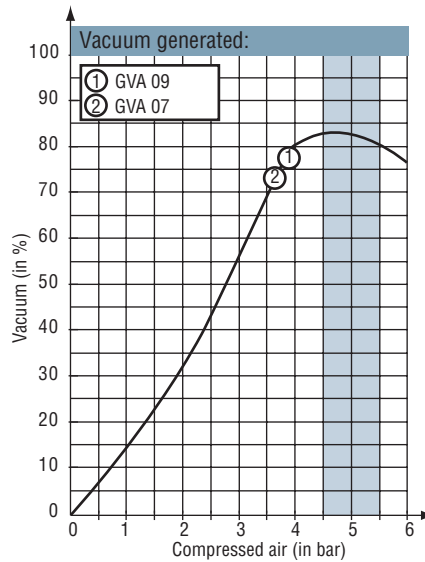



Option GVA V

(option valid for GVA, M5 vacuum outlet)

This option provides a vacuum outlet on the suction pad circuit which can be connected to a vacuum switch (e.g. PSE 100) to obtain vacuum rate data. Fitting for tube, diameter 4mm.

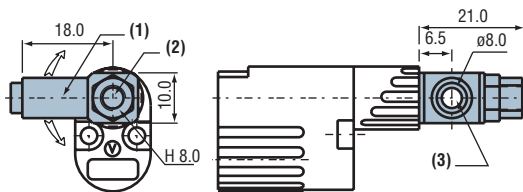

- (1) 360° turning
- (2) M5 female vacuum outlet
- (3) Fast vacuum outlet for tube, dia. 4

GVA C option

(Factory-mounted)

1/8 G female fitting for ejector exhaust manifold.

For multiple-ejector use, you are advised to use a Manifold base, GVAG2 option.

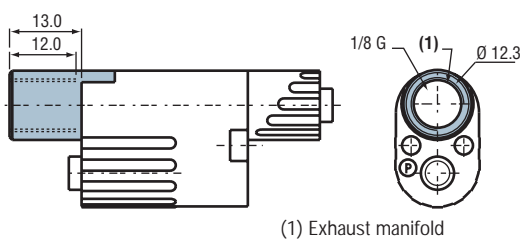

(1) Exhaust manifold

7

GVASIL option

1/8 G female fitting.

Silencer for GVA.

Noise level reduction of 10dBa.

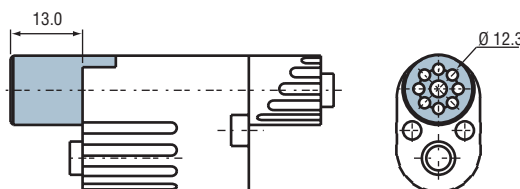

GVASPO option

More efficient silencer than the GVASIL.

Noise level reduction of 20dBa.

Adjustment for adaptation to models GVA07 or GVA09 is by tightening or loosening the white component.

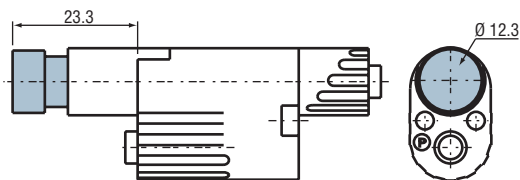

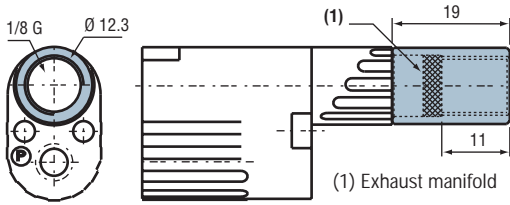

GVA F18 vacuum filter option

(Mounting on GVA M5 vacuum outlet.)

450 micron filtration to avoid blocking the ejector with dust.

Note : This option is compatible with the GVAV option In this case, the GVAV option must be mounted between the GVA and the GVAF

GVAG2 (3/4/6) Manifold accessory

GVA compatible (M5 or 24)

Possibility of manifold mounting,

4 models of base for 2, 3, 4 or 6 ejectors simultaneously, exhaust manifold and a single compressed air supply.

Material: POM - Cu Zn

models	GVA G2	GVA G3	GVA G4	GVA G6
L (mm)	55	72,5	90	125
M (mm)	45	62,5	80	115

GVAP manifold option

Plug for blanking off an unused ejector place.

GVAGB manifold option

1/4 Gas plug for blanking off the compressed air or exhaust.

Silencer mounting on exhaust

SILGV15 model

The two exhaust outlets must be open for GVA G4 and GVA G6. Each is fitted with a silencer.

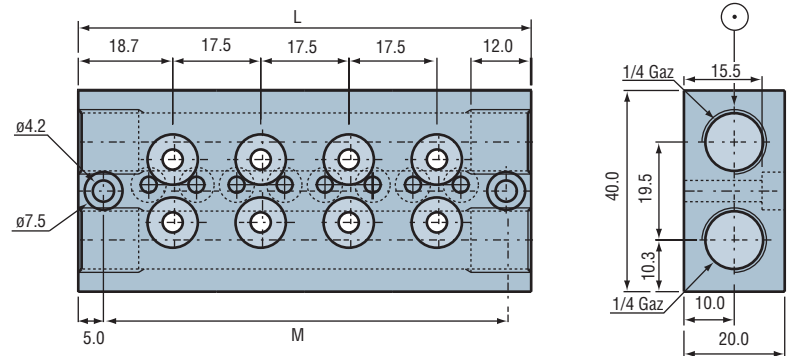

VR 05, 07, 09 series

Heavy duty in-line ejectors



Branch-specific applications

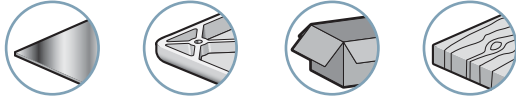

Description

The main advantage of the VR series in-line ejectors is that they can be mounted directly on the suction pad which simplifies wiring.

By integrating the ejector into the suction pad, we obtain a localized vacuum and, therefore, the possibility of obtaining multiple independent grips, even in the absence of objects.

It is also possible to supply vacuum to two or more suction pads using a 1/8 Gas or 1/4 Gas T-shaped fitting.

Additional information

Mounting on spring systems

- Spring system, series TS3, available strokes: 10, 30, 50, 70mm, page 5/3.

- TSO series anti-rotation spring system-, page 5/5.

- Ball-joint systems, IMU and VPYR series, pages 5/11.

Special:

- Possibility of using special materials such as stainless steel or plastic, based on specifications.

- Special characteristics such as suction rate or vacuum level.

- On request for the F18 model, M5 ancillary vacuum fitting for connection to a vacuum switch.

New function

- Possibility of adding a silencer (ref. SILGV10M5F)

- Vacuum or blow-off switch, on request.

Characteristics

model	Ø nozzle (mm)	air consumed (NI/min)	maximum-vacuum(%)	air drawn in (NI/min)	at air pressure (bar)
VR 05	0.5	12	87	7	5
VR 07	0.7	21	90	14	5
VR 09	0.9	36	90	21	5

Evacuation time in seconds per liter

% vacuum	10	20	30	40	50	60	70	80	85
VR05	0.92	1.96	3.18	4.63	6.38	8.79	12.17	18.96	27.39
VR07	0.46	0.98	1.58	2.28	3.13	4.27	5.8	8.55	11.01
VR09	0.31	0.65	1.05	1.52	2.09	2.85	3.87	5.7	7.34

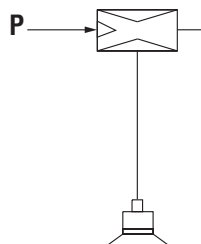

Specifications

Supply	Non-lubricated filtered air, pressure 2 to 6 bar
Optimum operating pressure	5 bar
Weight	20 g
Material	2017A - Cu Zn
Temperature	-10 to 80 °C

For all orders, please specify:

Model + Nozzle diameter + Vacuum outlet

1: Model
VR

2: Nozzle diameter
05 Ø 0.5mm
07 Ø 0.7mm
09 Ø 0.9mm

3: Vacuum outlet
M6 M6 Female
M18 1/8 Gas male
M14 1/4 Gas male
F18 1/8 Gas female
F14 1/4 Gas female

silencer reference SILGV10M5F

E.g. VR 07 M6

(VR series heavy duty in-line ejector, nozzle diameter 0.7 mm, M6 female fitting).

VR 05, 07, 09 series

Dimensions Curves



Dimensions

- (1) C.A. 1/4 Gas inlet, depth 10mm
- (2) M6 vacuum outlet, depth 6mm
- (3) Example of suction pad
- (4) Silencer
- (5) 1/8 Gas vacuum outlet, depth 7.5mm
- (6) 1/8 Gas vacuum outlet, depth 10mm
- (7) Compressed air
- (8) Exhaust
- (9) Hexagonal nut, 14 across flats
- (10) Hexagonal nut, 19 across flats

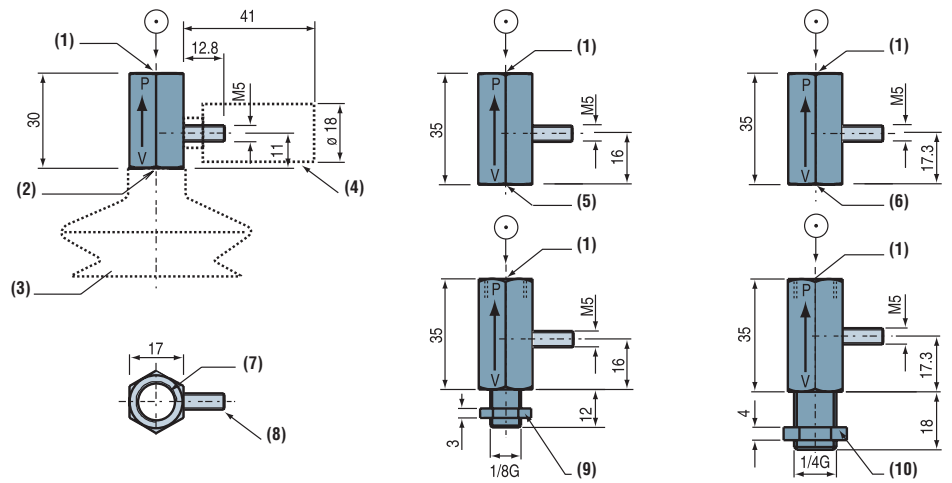

Advantages

- Wider range
- Can be adapted to all branches
- Light and compact
- Reduced gripping time
- Installed directly on the suction pads
- Excellent mechanical resistance
- Blow-off option
- Extended suction rate range
- No clogging
- Silent operation

Curves

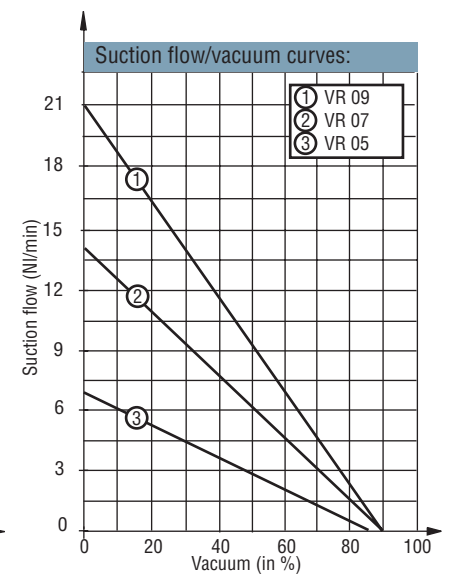
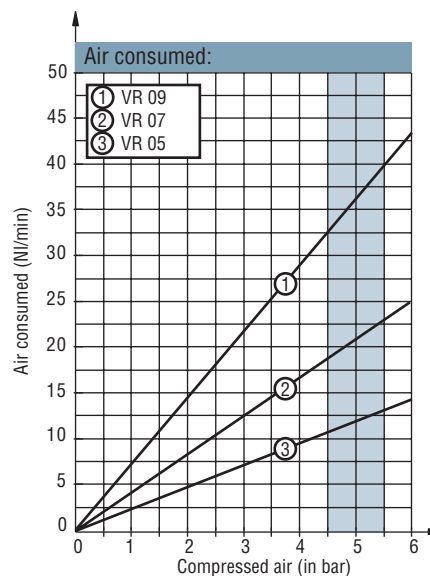
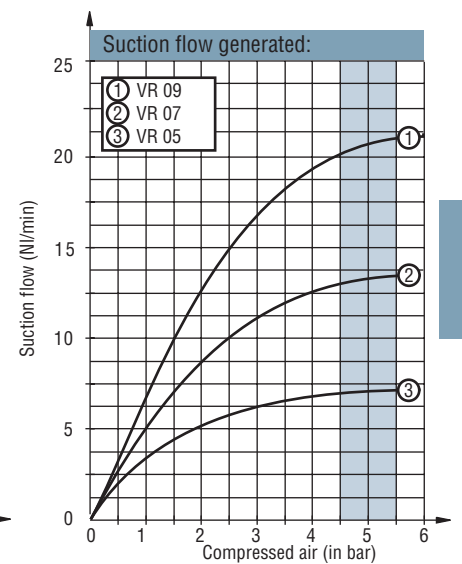
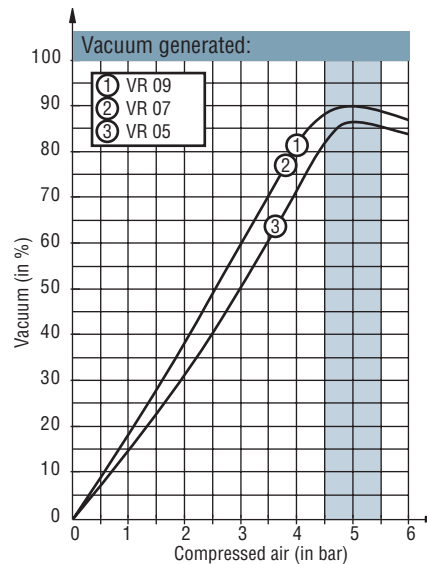

VR 10, 12, 14 series

Heavy duty in-line ejectors



Branch-specific applications

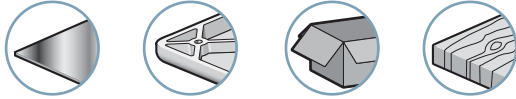

Description

Based on the same principle as the VR 05, 07, 09, the main advantage of the VR 10, 12, 14 series is that they can be mounted directly on larger suction pads due their optimum technical characteristics.

The aluminum design guarantees:

- Excellent mechanical resistance
- Light-weight
- Ideal for miscellaneous gripping.

Additional information

As standard

- New functions: vacuum switch or blow-off switch with or without silencer (SILGV 10).

On option

- MS2M5 or MS4M5 blow-off valves with check valve on vacuum (see page 11/3).

Special

- Coval offers the product best adapted to your needs based on your specifications and advises you according to your applications (material, shape, special technical characteristics).

Characteristics

model	Ø nozzle (mm)	air consumed (Nl/min)	maximum-vacuum(%)	air drawn in (Nl/min)	at air pressure (bar)
VR 10	1	44	90	27	5
VR 12	1.2	67	90	45	5
VR 14	1.4	108	90	64	5

Evacuation time in seconds per liter

% vacuum	10	20	30	40	50	60	70	80	85
VR 10	0.24	0.51	0.82	1.18	1.62	2.21	3.01	4.43	5.71
VR 12	0.14	0.3	0.49	0.71	0.97	1.33	1.81	2.66	3.42
VR 14	0.1	0.21	0.34	0.5	0.68	0.93	1.27	1.85	2.44

Specifications

Supply	Non-lubricated filtered air, pressure 2 to 6 bar
Optimum operating pressure	5 bar
Weight	50 g
Material	2017A - Cu Zn
Temperature	-10 to 80 °C / 14 to 186°F

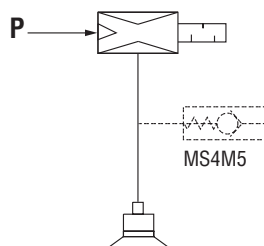

Advantages

- Wider range
- Can be adapted to all branches
- Light and compact
- Reduced gripping time
- Installed directly on the suction pads
- Excellent mechanical resistance
- Blow-off option
- Extended suction flow range
- No clogging
- Silent operation

For all orders, please specify:

Model + Nozzle diameter + Vacuum outlet + Silencer

1: Model	2: Nozzle diameter	3: Vacuum outlet	4: Silencer
VR	10 Ø 1mm	M14 1/4 Gas male	S SILGV 10
	12 Ø 1.2mm	M10 ⁽¹⁾ M10x125 male	K SILK 18 C ⁽²⁾
	14 Ø 1.4mm		

(1) especially for VPG 60, 80 and 95 suction pads

(2) SILK 18 C through type silencer dimensions, see page 11/2.

E.g. VR 12 M10 S

(VR series heavy duty in-line ejector, nozzle diameter 12mm, M10x125 male vacuum outlet with silencer SILGV 10).

VR 10, 12, 14 series

Dimensions Curves



Dimensions

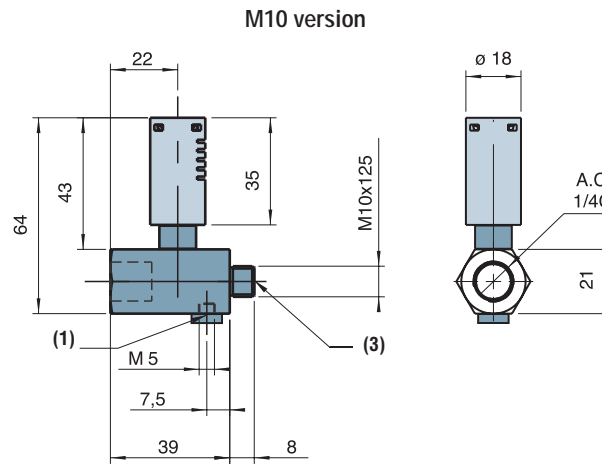
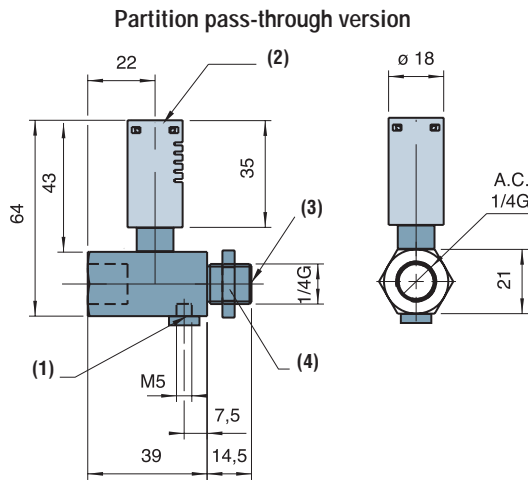

VR + MS4M5 version

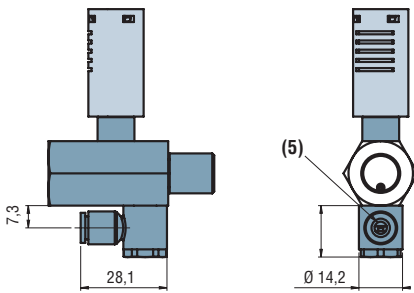

- (1) Blow-off or vacuum switch
- (2) Silencer
- (3) Vacuum
- (4) Hexagonal nut, 19 across flats
- (5) Push fitting, outside Ø6

Curves

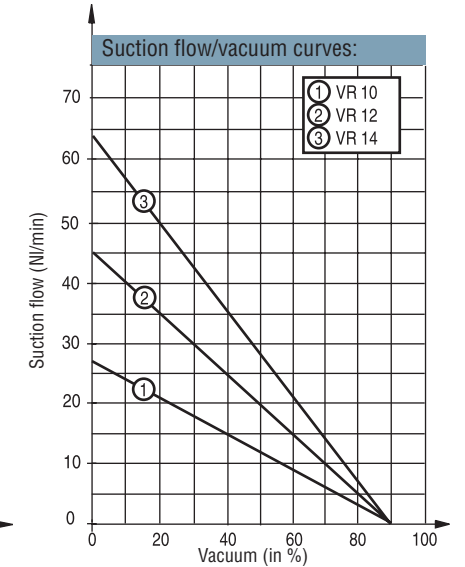
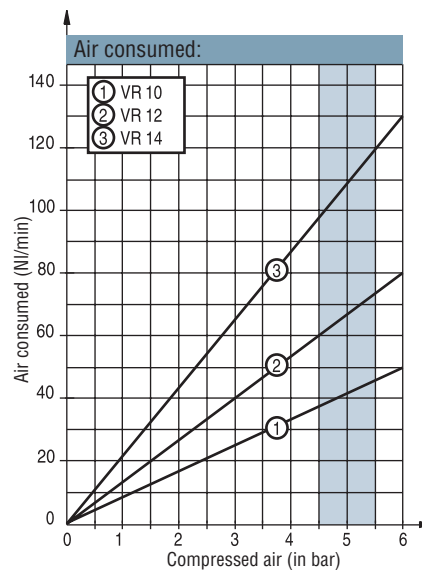
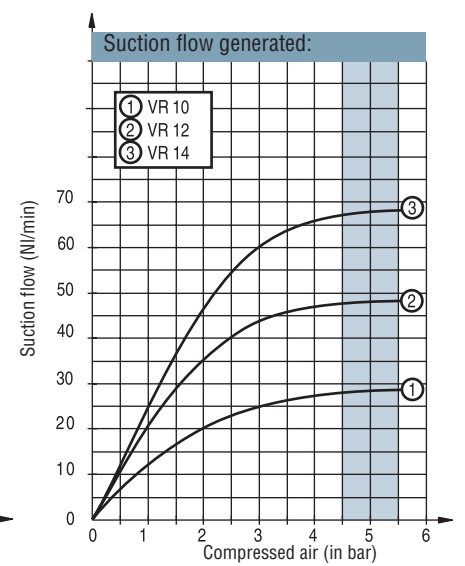
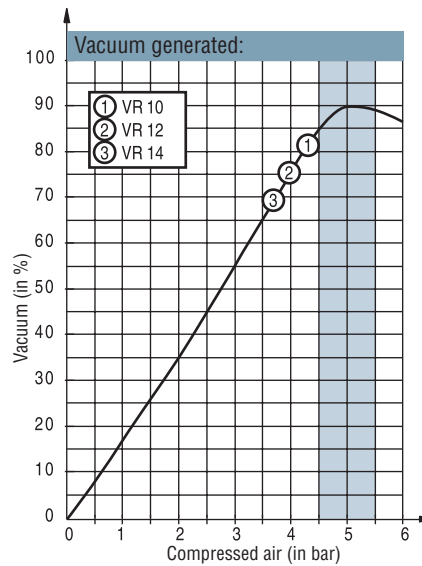

GVR 09 S, 10, 12, 14 series

Micro ejectors



Branch-specific applications

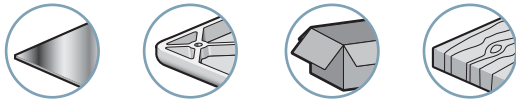

Description

The GVR range is designed for an industrial environment:

- Compact
- Light
- Optimized technical characteristics
- Pollution-resistant with its through type silencer (SILK 18C)
- Easy to integrate on the lifters
- Partition pass-through mounting using M10 screws (GVR 09S)

Additional information

As standard

- Vacuum switch or blow-off switch with SILGV 10. SILK18C silencer (through type) on request.

On option

- MS2M5 or MS4M5 blow-off valves with check valve on vacuum (see page 11/3).

Characteristics

models	Ø nozzle (mm)	air consumed (NI/min)	air drawn in (NI/min)	vacuum (%)	at air pressure (bar)
GVR 09 S	0.9	36	21	90	5
GVR 10	1	44	27	90	5
GVR 12	1.2	67	45	90	5
GVR 14	1.4	108	64	90	5

Advantages

- Can be adapted to all branches
- Light and compact
- Reduced gripping time
- Installed directly on the suction pads
- Excellent mechanical resistance
- Blow-off option
- No clogging
- Silent operation

Evacuation time in seconds per liter

% vacuum	10	20	30	40	50	60	70	80	85
GVR 09 S	0.31	0.65	1.05	1.52	2.09	2.85	3.87	5.7	7.34
GVR 10	0.24	0.51	0.82	1.18	1.62	2.21	3.01	4.43	5.71
GVR 12	0.14	0.3	0.49	0.71	0.97	1.33	1.81	2.66	3.42
GVR 14	0.1	0.21	0.34	0.5	0.68	0.93	1.27	1.85	2.44

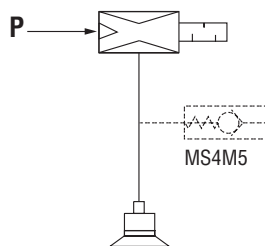

Specifications

Supply	Non-lubricated filtered air, pressure 2 to 6 bar
Optimum operating pressure	5 bar
Weight	40g
Material	2017A - Cu Zn
Temperature	-10 to 80 °C / 14 to 186°F

For all orders, please specify:

Model + Nozzle diameter + Silencer

1: Model	2: Nozzle diameter	4: Silencer
GVR	09S Ø 0.9mm	- without
	10 Ø 1mm	S SILGV 10
	12 Ø 1.2mm	K SILK 18 C
	14 Ø 1.4mm	

E.g. GVR 12 K

(GVR series micro ejector, nozzle diameter 1.2mm with SILK 18 C silencer).

GVR 09 S, 10, 12, 14 series

Dimensions Curves



Dimensions

GVR 10, 12, 14 + MS4M5

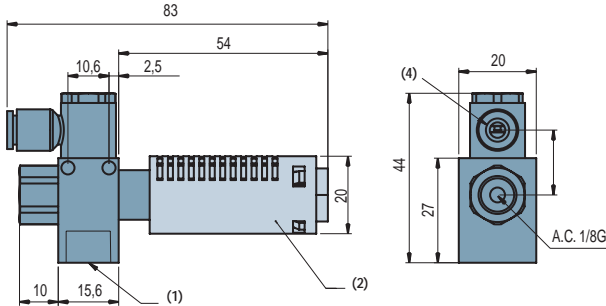

GVR 10, 12, 14

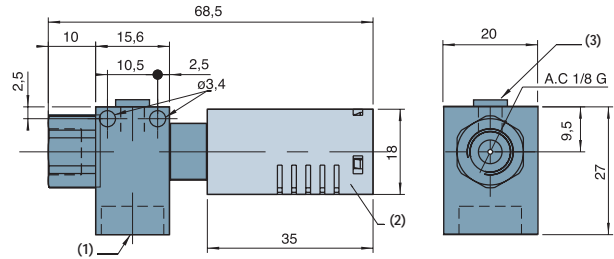

GVR 09 S

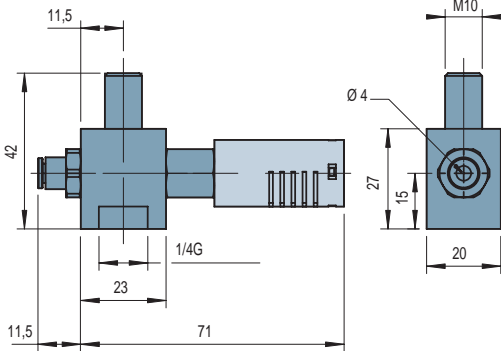

- (1) Vacuum 1/4 G
- (2) Silencer
- (3) M5 vacuum switch
- (4) Push fitting, outside Ø6

Curves

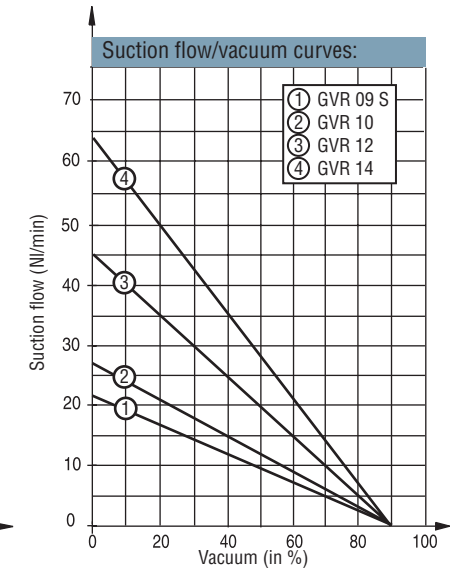
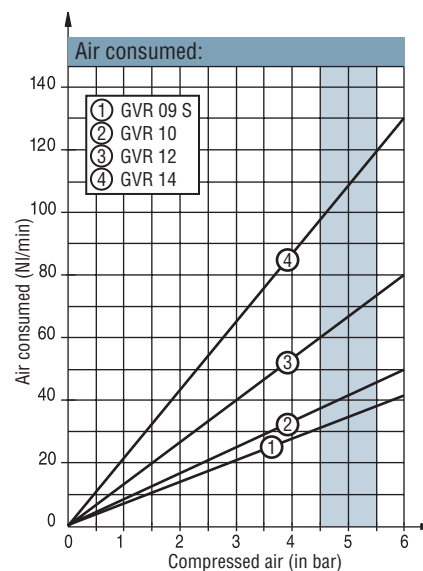
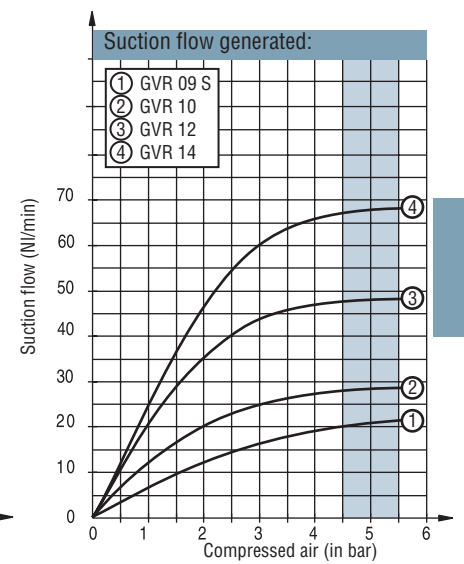
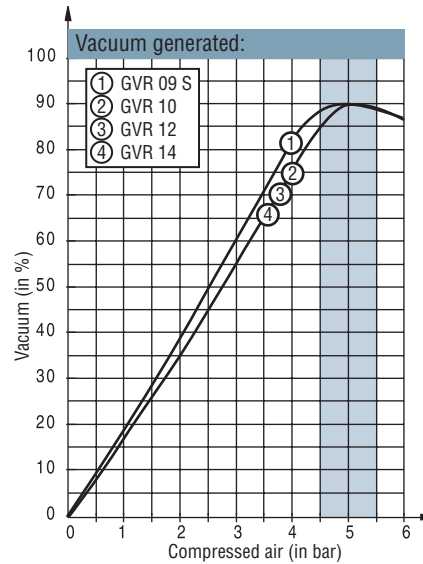



Branch-specific applications

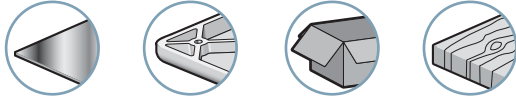

Description

The GV series standard ejectors are light-weight and compact. This double advantage makes them easy to integrate into the robotic system.

The GV...VR version has an electromechanical vacuum switch which allows the user to check the vacuum level in the suction pad circuit at any time.

Additional information

Accessory

■ Compressed air control valve, COVAL reference: AP2. See page13/9.

On request

■ Mounting of an electronic vacuum switch on models GV 15 and GV 20.

■ Mounting of a vacuum switch, factory settings approximately -350mbar, model V.

■ Mounting of an uncloggable through type silencer, index K instead of S for models 10, 15 and 20.

Characteristics

models	Ø nozzle (mm)	air consumed (NI/min)	vacuum (%)		air drawn in (NI/min)		at air pressure (bar)
			X	N	X	N	
GV 05	0.5	13	56	85	9	6	5
GV 10	1	44	56	90	36	27	5
GV 15	1.5	100	56	90	95	63	5
GV 20	2	180	56	90	165	110	5

Evacuation time in seconds per liter

% vacuum	10	20	30	40	50	60
GV 05X	0.74	1.66	2.89	3.69	4.71	6.12
GV 10X	0.19	0.42	0.72	0.92	1.18	1.53
GV 15X	0.07	0.16	0.27	0.35	0.45	0.58
GV 20X	0.04	0.09	0.15	0.2	0.26	0.33

% vacuum	10	20	30	40	50	60	70	80	85
GV 05N	1.07	2.3	3.73	5.45	7.55	10.48	14.74	24.31	-
GV 10N	0.24	0.51	0.82	1.18	1.62	2.21	3.01	4.43	5.71
GV 15N	0.1	0.22	0.35	0.51	0.7	0.95	1.29	1.9	2.45
GV 20N	0.05	0.11	0.18	0.26	0.35	0.48	0.65	0.96	1.23

7

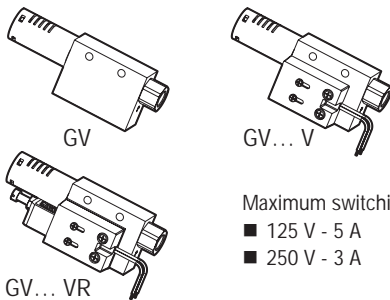

Advantages

- Can be adapted to all branches
- Light and compact
- Excellent mechanical resistance
- Optimized vacuum adjustment thanks to two types of vacuum switch
- No clogging thanks to the through type silencer
- Silent operation

Specifications

Supply	Non-lubricated filtered air, pressure 2 to 6 bar		
Optimum operating pressure	5 bar		
Weight (g)	GV 05 / GV 10	GV 15	GV 20
GV/GV...V/GV...VR	80/100/120	140/160/190	350/440/460
Material	2017A - Cu Zn		
Temperature	-10 to 80 °C / 14 to 186°F		
Hysteresis (VR version)	40 to 140mbar		

For all orders, please specify: Model + Nozzle diameter + Vacuum level + Silencer + Options

1: Model	2: Nozzle diameter	3: Vacuum level	4: Silencer	5: Options
GV	05 Ø 0.5mm 10 Ø 1mm 15 Ø 1.5mm 20 Ø 2mm	X 56 % vacuum N 90 % vacuum	- without silencer S with silencer K through type silencer	- without VR adjustable vacuum switch -200 to -530mb V pre-set vacuum switch, approx. -350mb

E.g. GV 05 N

(GV series standard ejector, nozzle diameter 0.5mm with 90 % vacuum, without silencer and without options).

GV series

Dimensions Curves and circuit diagrams



Dimensions

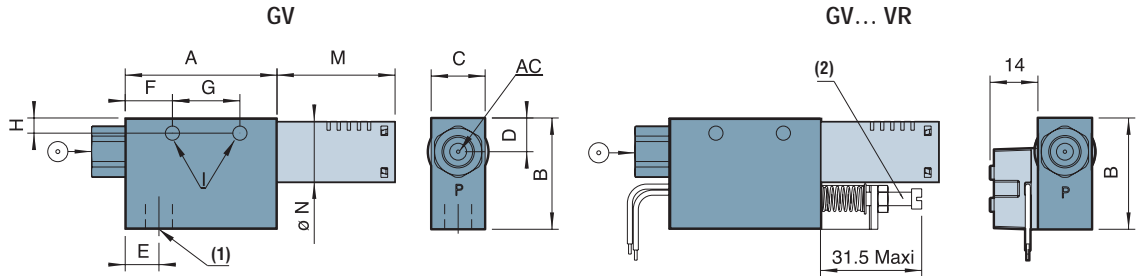

models	A (mm)	B (mm)	B' (mm)	C (mm)	D (mm)	E (mm)	F (mm)	G (mm)	H (mm)	I (mm)	Vacu-um	K	C.A.	M (mm) S K	N (mm) S K
GV 05/10	45	33	33	16	10	8	14	20	4.5	2-4.2	G 1/8"	10	G 1/8"	36 58	18 20
GV 15	63	35	35	20	11	10	20	25	5	2-4.5	G 1/4"	15	G 1/4"	46 58	20 20
GV 20	85	40	50	30	15	13	28	32	7	2-6	G 3/8"	20	G 1/4"	62 121	30 20

Circuit diagrams

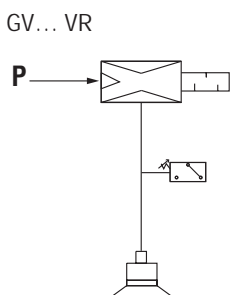
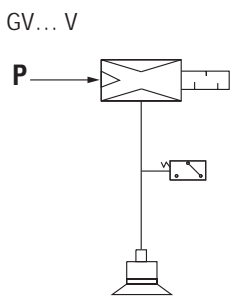
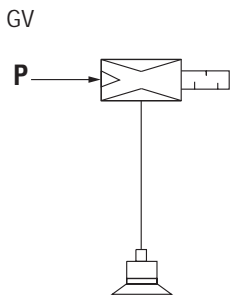

Curves

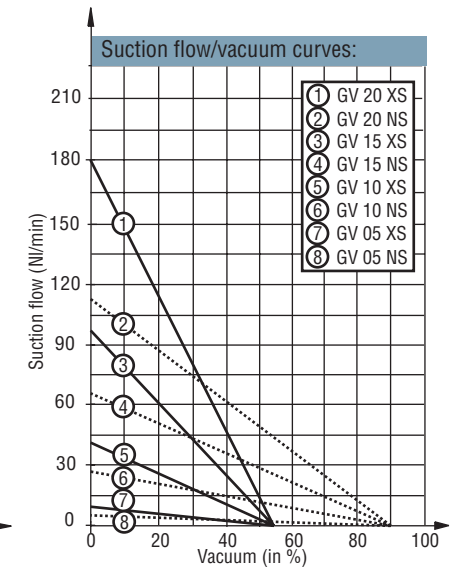
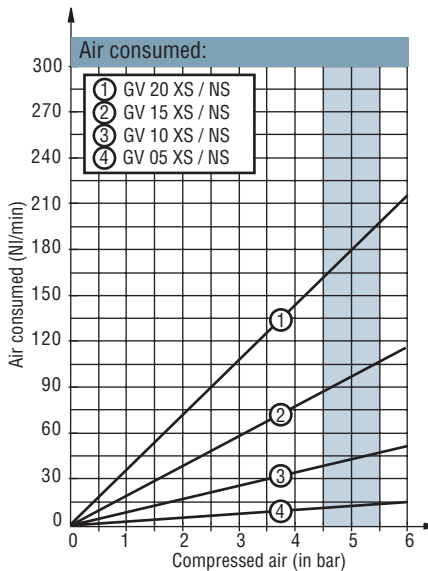
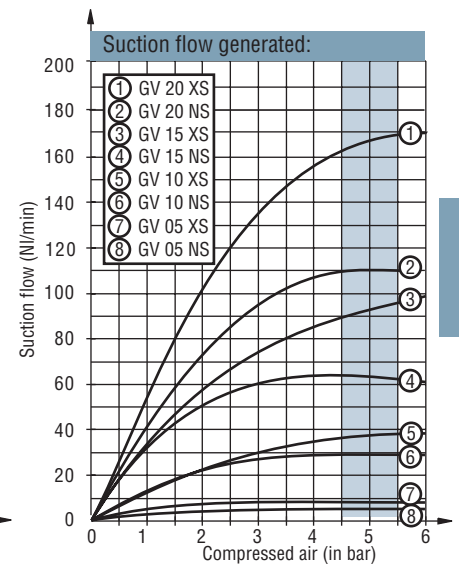
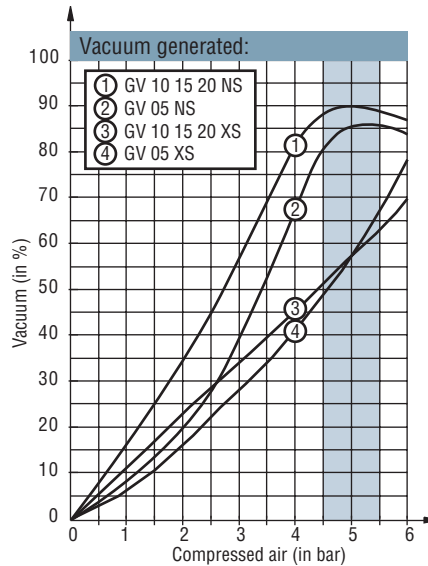

GVP

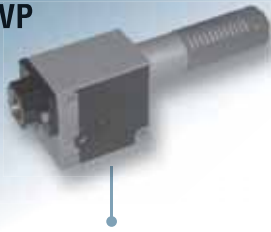

P 8/2

- Modular vacuum pump
- nozzle Ø: 1.2 ; 1.5 ; 2.0 ; 2.5 ; 3mm
- Suction flow rate: 150 to 450 NI/min
- Optimum supply pressure: 4 to 5 bar
- Integrated silencer

- Modular design thanks to the different options
- Compact
- Optimized performance for handling all types of objects
- Gripping time two times faster than multi-stage technology
- Silent operation
- No clogging
- Can be adapted to all branches

GVC



P 8/4

- Automatic blow-off capacity vacuum pump
- nozzle Ø: 1.2 ; 1.5mm
- Suction flow rate: 63 to 95 NI/min
- Optimum supply pressure: 4 to 5 bar
- Integrated compressed air tank
- Integrated silencer

- Ideal for high throughput applications
- Adjustable blow-off flow
- Compact
- Optimized performance for handling all types of objects
- Silent operation
- No clogging
- Can be adapted to all branches

GVCS



P 8/6

- Vacuum pump with automatic blow-off and electric vacuum control
- nozzle Ø: 1.2 ; 1.5mm
- Suction flow rate: 63 to 95 NI/min
- Optimal supply pressure: 4 to 5 bar
- Integrated vacuum control
- Integrated compressed air tank
- Integrated silencer

- Ideal for high throughput applications
- Reduced wiring
- Adjustable blow-off flow
- Compact
- Optimized performance for handling all types of objects
- Silent operation
- No clogging
- Can be adapted to all branches

GVPS



P 8/8

- Vacuum pump with electric vacuum control
- nozzle Ø: 1.2 ; 1.5 ; 2.0 ; 2.5 ; 3mm
- Suction flow rate: 150 to 450 NI/min
- Optimum supply pressure: 4 to 5 bar
- Integrated electric vacuum control
- Integrated silencer

- Modular design thanks to the different options
- Compact
- Optimized performance for handling all types of objects
- Silent operation
- No clogging
- Can be adapted to all branches

GVPD



P 8/10

- Vacuum pump with blow-off and electric vacuum control
- nozzle Ø: 1.2 ; 1.5 ; 2.0 ; 2.5 ; 3mm
- Suction flow rate: 150 to 450 NI/min
- Optimum supply pressure: 4 to 5 bar
- Integrated vacuum control and blow-off
- Integrated silencer
- Adjustable blow-off flow

- Modular design thanks to the different options
- Compact
- Optimized performance for handling all types of objects
- Silent operation
- No clogging
- Can be adapted to all branches

GVS



P 8/12

- Safety vacuum pump with blow-off and electric vacuum control
- nozzle Ø: 1.2 ; 1.5 ; 2.0 ; 2.5 ; 3.0mm
- Optimum supply pressure: 4 to 5 bar
- Two integrated check valves

- Ideal for handling air-tight objects
- Safety guaranteed by check valves
- Optimal performance
- Silent operation
- No clogging

The range of Coval modular vacuum pumps

Advantages

- Reduced energy consumption
- Reduced noise levels
- Increased life expectancy
- Can be adapted to all branches
- Technical development of the Coval valve resulting from technological advances in aerospace and automotive applications.

New optimized fluidics

The COVAL range of modular vacuum pumps operates with a pressure supply of 4 bar.

Developed by COVAL over the years, this range is the result of research and optimized technical solutions. Thanks to the new fluidics, this range of vacuum pumps offer an optimized performance.

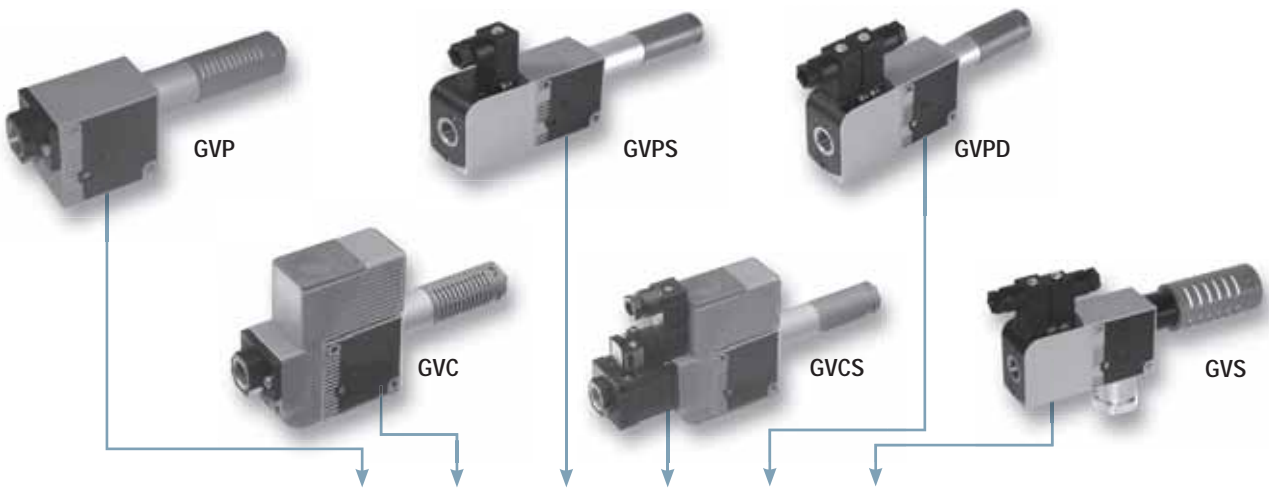

model	MODULAR VACUUM PUMPS						INTELLIGENT VACUUM PUMPS			
	GVP	GVC	GVPS	GVCS	GVPD	GVS	GEM	GEMP	GVE	GVMAX
C.A. ⁽¹⁾ : 1/4G - 6x8	■	■	■	■	■	■	■	■	■	■
C.A. Control ⁽¹⁾			■	■	■	■	■		■	■
Blow-off control					■	■	■			■
Integrated pressure regulator							■	■		
Blow-off by capacity		■		■						
Network pressure blow-off							■			■
Electric vacuum switch	☼	☼	☼	☼	☼	☼	☼	☼		
Pneumatic vacuum switch	☼	☼	☼	☼	☼	☼	☼	☼		■
Visual electronic vacuum switch	☼	☼	☼	☼	☼	☼	☼	☼		■
Vacuum gauge	☼	☼	☼	☼	☼	☼	☼	☼		
Vacuum check-valve	☼		☼	☼	☼	■	☼	☼	■	■
Electric control			■	■	■	■	■			■
Pneumatic control			☼	☼	☼	■			■	■
Air savings with release										■
Air savings without release									■	

■ : Standard or integrated ☼ : Option (1) C.A.: Compressed air

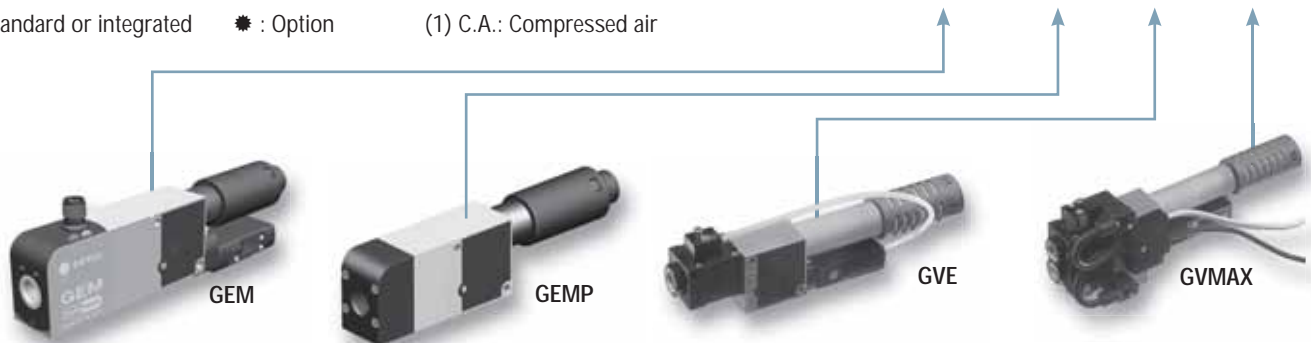



Branch-specific applications

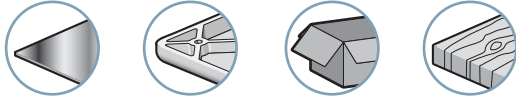

Description

The GVP series vacuum pumps are the simplest in the modular range. They exist in 5 levels of power (evacuation time) and 3 different levels of maximum vacuum:

- Version X (50% vacuum for very porous products).
- Version T (75% vacuum for porous products).
- Version N (90% vacuum for air-tight products).

For the same nozzle diameter, the suction flow increases proportionally to the decrease in the maximum vacuum level.

In addition to suction pads, they can also be used for dosing liquid, spraying and tank depressurization.

Advantages

- Can be adapted to all branches
- Optimized performance for handling all types of objects
- Modular design thanks to the different options
- Light and compact
- Silent operation
- No clogging thanks to the through type silencer

Characteristics

model	Ø nozzle (mm)	air consumed (Nl/min)	maximum vacuum (%)			air drawn in (Nl/min)		
			X	T	N	X	T	N
GVP 12	1.2	67	40	75	90	150	63	45
GVP 15	1.5	100	50	75	90	180	95	70
GVP 20	2	180	50	75	90	250	160	125
GVP 25	2.5	270	50	75	90	360	240	200
GVP 30	3	400	50	75	90	450	330	265

As standard, versions N and T are delivered with silencer S and version X with silencer K. Only exception, the GVP 30 is fitted with silencer K.

Evacuation time in seconds per liter

% vacuum	10			20			30			40			50			60			70			80			85		
	X	T	N	X	T	N	X	T	N	X	T	N	X	T	N	X	T	N	X	T	N	X	T	N	X	T	N
GVP12	0.05	0.10	0.14	0.11	0.22	0.30	0.22	0.37	0.49	0.62	0.55	0.71	-	0.78	0.97	-	1.16	1.33	-	1.92	1.81	-	-	2.66	-	-	3.42
GVP15	0.04	0.07	0.09	0.09	0.15	0.20	0.15	0.24	0.32	0.27	0.36	0.46	-	0.52	0.63	-	0.77	0.85	-	1.27	1.16	-	-	1.71	-	-	2.20
GVP20	0.03	0.04	0.06	0.06	0.09	0.12	0.11	0.14	0.19	0.19	0.22	0.28	-	0.31	0.38	-	0.46	0.52	-	0.76	0.71	-	-	1.04	-	-	2.13
GVP25	0.02	0.03	0.03	0.04	0.06	0.07	0.08	0.10	0.11	0.14	0.14	0.16	-	0.21	0.22	-	0.30	0.30	-	0.50	0.41	-	-	0.60	-	-	0.77
GVP30	0.01	0.02	0.02	0.03	0.04	0.05	0.06	0.07	0.08	0.11	0.10	0.12	-	0.15	0.17	-	0.22	0.23	-	0.37	0.31	-	-	0.45	-	-	0.58

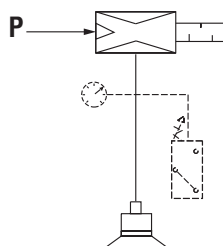

Specifications

Supply	Non-lubricated filtered air, pressure 2 to 6 bar
Optimum pressure	4 bar
Weight	100 to 265 g
Material	POM - 2017A - Cu Zn
Temperature	-10 to 80 °C / 14 to 186°F

For all orders, please specify:

Model + Nozzle diameter + Characteristic + Silencer + Fitting

1: Model	2: Nozzle diameter	3: Characteristic	4: Silencer	5: C.A. fitting
GVP	12 1.2 mm	X 50% vacuum	- Without silencer	14 1/4 G BSPP
	15 1.5 mm	T 75% vacuum	S ⁽¹⁾ Diffuser	68 6x8 calibrated tube
	20 2 mm	N 90% vacuum	K Through-type	
	25 2.5 mm			
	30 3 mm			

(1) no silencer for nozzle Ø 30.

E.g. GVP 30 T K 68

(GVP series modular vacuum pump, nozzle diameter 3mm, 75 % vacuum with through type silencer and 6x8 calibrated tube fitting)

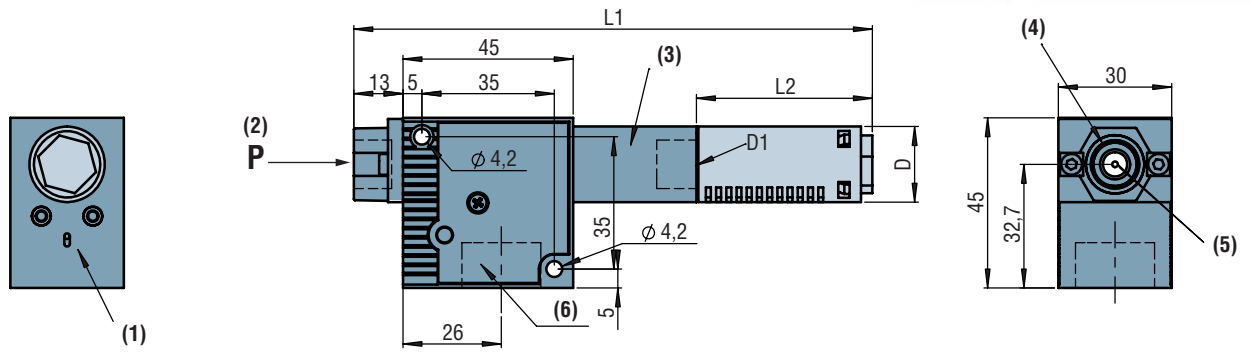

- (1) Option mounting zone
- (2) 4 bar compressed air tank
- (3) Exhaust
- (4) 1/4 Gas, fast 6x8
- (5) Compressed air connection
- (6) Vacuum 1/2 Gas

models	D (mm)		D1 (Gas)		L1 ⁽¹⁾ (mm)		L2 (mm)		
	X	N/T	X	N/T	X	N/T	S	K(N/T)	K(X)
GVP 12	30	20	1/2	1/4	160	127	45	68	121
GVP 15	30	20	1/2	1/4	160	137	45	68	121
GVP 20	30	30	1/2	1/2	198	137	60	121	121
GVP 25	30	30	1/2	1/2	198	137	60	121	121
GVP 30	30	30	1/2	1/2	270	270	-	121	121

(1) L1 with standard silencer (S).

Additional information

Options

- Vacuum switches see page 8/16.
- Other options see pages 8/17 and 8/18.

Curves

See page 8/19.



Branch-specific applications

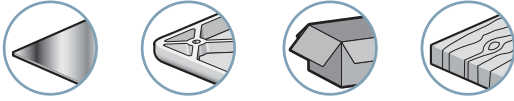

Description

GVC series vacuum pumps are vacuum pumps with automatic blow-off. This characteristic allows the gripped object to be automatically released and thus accelerates throughput and simplifies venturi vacuum pump wiring.

For vacuum generation control, refer to the GVCS range.

The addition of a 1/8 gas fitting to the capacity allows an additional compressed air tank to be connected in order to increase blow-off capacity e.g. for large diameter suction pads.

Advantages

- Ideal for high throughput applications
- Automatic blow-off
- Can be adapted to all branches
- Adjustable blow-off flow
- Light and compact
- Optimized performance for handling all types of objects
- Silent operation
- No clogging

Characteristics

model	Ø nozzle (mm)	air consumed (NI/min)	maximum vacuum (%)		air drawn in (NI/min)	
			T	N	T	N
GVC 12	1.2	67	75	90	63	45
GVC 15	1.5	100	75	90	95	70

Versions N and T are delivered with silencer S as standard.

Evacuation time in seconds per liter

% vacuum	10		20		30		40		50		60		70		80		85	
	T	N	T	N	T	N	T	N	T	N	T	N	T	N	T	N	T	N
GVC 12	0.10	0.14	0.22	0.30	0.37	0.49	0.55	0.71	0.78	0.97	1.16	1.33	1.92	1.81	-	2.66	-	3.42
GVC 15	0.07	0.09	0.15	0.20	0.24	0.32	0.36	0.46	0.52	0.63	0.77	0.85	1.27	1.16	-	1.71	-	2.20

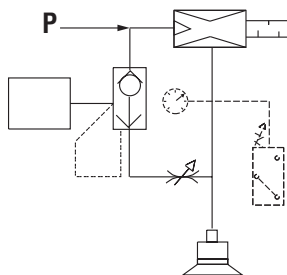

Specifications

Supply	Non-lubricated filtered air, 2 to 6 bar
Optimum pressure	4 bar
Material	POM - 2017A – Cu Zn
Temperature	0 to 60°C / 32 to 140°F
Suction rate	Adjusted by flow restrictor
Operating frequency	2 Hz

For all orders, please specify:

Model + Nozzle diameter + Characteristic + Silencer + Fitting

1: Model	2: Nozzle diameter	3: Characteristic	4: Silencer	5: C.A. fitting
GVC	12 1.2 mm 15 1.5 mm	T 75% vacuum N 90% vacuum	- Without silencer S Diffuser K Through-type	14 1/4 G BSPP 68 6x8 calibrated tube

E.g. GVC 15 T K 68

(GVC series vacuum pump with automatic blow-off, nozzle diameter 1.5 mm, 75% vacuum with through type silencer and 6x8 calibrated tube fitting)

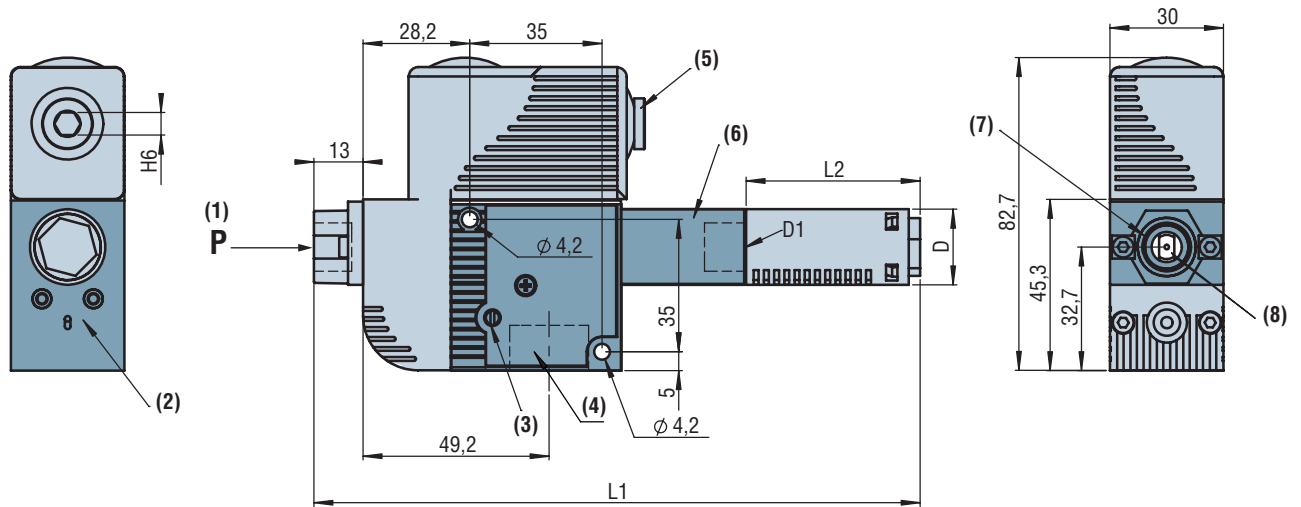

- | | |
|-------------------------------|-------------------------------------|
| (1) 4 bar compressed air tank | (5) 1/8 gas plug for blow-off boost |
| (2) Option mounting zone | (6) Exhaust |
| (3) Blow-off adjustment | (7) 1/4 Gas, fast 6x8 |
| (4) Vacuum 1/2 Gas | (8) Compressed air connection |

models	D	D1	L1 ⁽¹⁾	L2	
	(mm)	(Gas)	(mm)	(mm)	(mm)
GVC 12	20	1/4	150.2	S	K
GVC 15	20	1/4	160.2	45	68

(1) L1 with standard silencer (S).

Additional information

Options

See pages 8/16 and 8/18.

- Blow-off adjustment underneath for manifold mounting.
- 1/8 gas hole on the front for installation of a vacuum gauge.
- Vacuum switch options.

Curves

See page 8/19.



Branch-specific applications

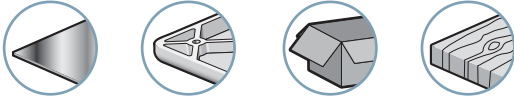

Advantages

- Ideal for high throughput applications
- Automatic blow-off
- Can be adapted to all branches
- Reduced wiring and easy-to-use
- Optimized performance for handling all types of objects
- Adjustable blow-off flow
- Light and compact
- Silent operation
- No clogging

Description

GVCS series vacuum pumps are identical in design to the GVC series. Their specific characteristic is the control of vacuum generation by integrated valve.

The valve control function speeds up response time and facilitates wiring by integrating all the functions. For longer blow-off, please refer to the GVPD range.

The addition of a 1/8 gas fitting to the capacity allows an additional compressed air tank to be connected in order to increase blow-off capacity e.g. for large diameter suction pads.

Characteristics

model	Ø nozzle (mm)	air consumed (NI/min)	maximum vacuum (%)		air drawn in (NI/min)	
			T	N	T	N
GVCS 12	1.2	67	75	90	63	45
GVCS 15	1.5	100	75	90	95	70

Versions N and T are delivered with silencer S as standard.

Evacuation time in seconds per liter

% vacuum	10		20		30		40		50		60		70		80		85	
	T	N	T	N	T	N	T	N	T	N	T	N	T	N	T	N	T	N
GVCS 12	0.10	0.14	0.22	0.30	0.37	0.49	0.55	0.71	0.78	0.97	1.16	1.33	1.92	1.81	-	2.66	-	3.42
GVCS 15	0.07	0.09	0.15	0.20	0.24	0.32	0.36	0.46	0.52	0.63	0.77	0.85	1.27	1.16	-	1.71	-	2.20

Specifications

Supply	Non-lubricated filtered air, 2 to 6 bar
Optimum pressure	4 bar
Material	POM - 2017A – Cu Zn – PA6 15% FG
Temperature	0 to 60°C / 32 to 140°F
Suction rate	Adjusted by flow restrictor
Number of valve operations	15 million
Operating frequency	Maximum 2 Hertz
Function	N.C.
	N.O. in 24V DC on request

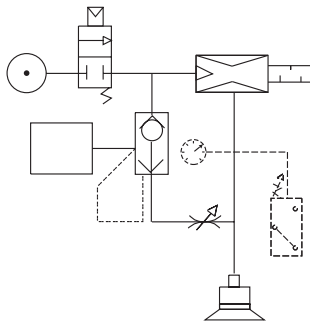

For all orders, please specify:

Model + Nozzle diameter + Characteristic + Silencer + Fitting + Control

1: Model	2: Nozzle diameter	3: Characteristic	4: Silencer	5: C.A. fitting	6: Controls
GVCS	12 1.2 mm 15 1.5 mm	T 75% vacuum N 90% vacuum	- Without silencer S Diffuser K Through-type	14 1/4 G BSPP 68 6x8 calibrated tube	P1 pneumatic E1 24V DC N.C. E Other voltages on request

E.g. GVCS 15 T K 68 P1

(GVCS series electrically controlled vacuum pump with automatic blow-off, nozzle diameter 1.5mm, 75% vacuum with through type silencer, 6x8 calibrated tube fitting and pneumatic control)



Branch-specific applications

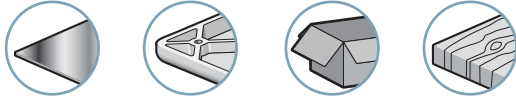

Advantages

- Integrated electric vacuum control
- Can be adapted to all branches
- Optimized performance for handling all types of objects
- Reduced wiring and easy-to-use
- Modular design thanks to the different options
- Light and compact
- No clogging thanks to the through type silencer
- Silent operation

Description

GVPS series vacuum pumps control vacuum generation using an integrated valve. This installation simplifies wiring and reduces vacuum pump response times.

The valve is electrically controlled (24 V DC).

Characteristics

model	Ø nozzle (mm)	air consumed (Nl/min)	maximum vacuum (%)			air drawn in (Nl/min)		
			X	T	N	X	T	N
GVPS 12	1.2	67	40	75	90	150	63	45
GVPS 15	1.5	100	50	75	90	180	95	70
GVPS 20	2	180	50	75	90	250	160	125
GVPS 25	2.5	270	50	75	90	360	240	200
GVPS 30	3	400	50	75	90	450	330	265

As standard, versions N and T are delivered with silencer S and version X with silencer K. Only exception, the GVPS 30 is fitted with silencer K.

Evacuation time in seconds per liter

% vacuum	10			20			30			40			50			60			70			80			85		
	X	T	N	X	T	N	X	T	N	X	T	N	X	T	N	X	T	N	X	T	N	X	T	N	X	T	N
GVPS 12	0.05	0.10	0.14	0.11	0.22	0.30	0.22	0.37	0.49	0.62	0.55	0.71	-	0.78	0.97	-	1.16	1.33	-	1.92	1.81	-	-	2.66	-	-	3.42
GVPS 15	0.04	0.07	0.09	0.09	0.15	0.20	0.15	0.24	0.32	0.27	0.36	0.46	-	0.52	0.63	-	0.77	0.85	-	1.27	1.16	-	-	1.71	-	-	2.20
GVPS 20	0.03	0.04	0.06	0.06	0.09	0.12	0.11	0.14	0.19	0.19	0.22	0.28	-	0.31	0.38	-	0.46	0.52	-	0.76	0.71	-	-	1.04	-	-	2.13
GVPS 25	0.02	0.03	0.03	0.04	0.06	0.07	0.08	0.10	0.11	0.14	0.14	0.16	-	0.21	0.22	-	0.30	0.30	-	0.50	0.41	-	-	0.60	-	-	0.77
GVPS 30	0.01	0.02	0.02	0.03	0.04	0.05	0.06	0.07	0.08	0.11	0.10	0.12	-	0.15	0.17	-	0.22	0.23	-	0.37	0.31	-	-	0.45	-	-	0.58

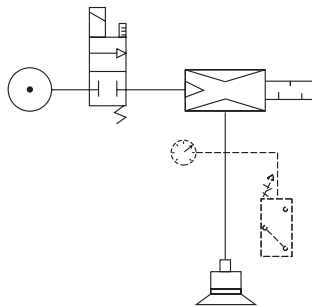

Specifications

Supply	Non-lubricated filtered air, 2 to 6 bar
Optimum pressure	4 bar
Voltage	24 V DC
Power	0.7 W
Materials	POM - 2017A – Cu Zn – PA6 15% FG
Temperature	0 to 60 °C / 32 to 140°F
Number of valve operations	10 million
Operating frequency	Maximum 2 Hz
Function	N.C. (N.O. on request)

For all orders, please specify:

Model + Nozzle diameter + Characteristic + Silencer + Fitting + Control

1: Model	2: Nozzle diameter	3: Characteristic	4: Silencer	5: C.A. fitting	6: Controls
GVPS	12 1.2 mm 15 1.5 mm 20 2 mm 25 2.5 mm 30 3mm	X 50% vacuum T 75% vacuum N 90% vacuum	- Without silencer S ⁽¹⁾ Diffuser K Through-type	14 1/4 G BSPP	E1 24V DC N.C. E Other voltages on request

(1) no silencer (S) for nozzle Ø 30.

E.g. GVPS 30 N K 68 E1

(GVPS series electrically-controlled vacuum pump, nozzle diameter 3mm, 90% vacuum with through type silencer, 6x8 calibrated tube fitting and 24V DC N.C. control)

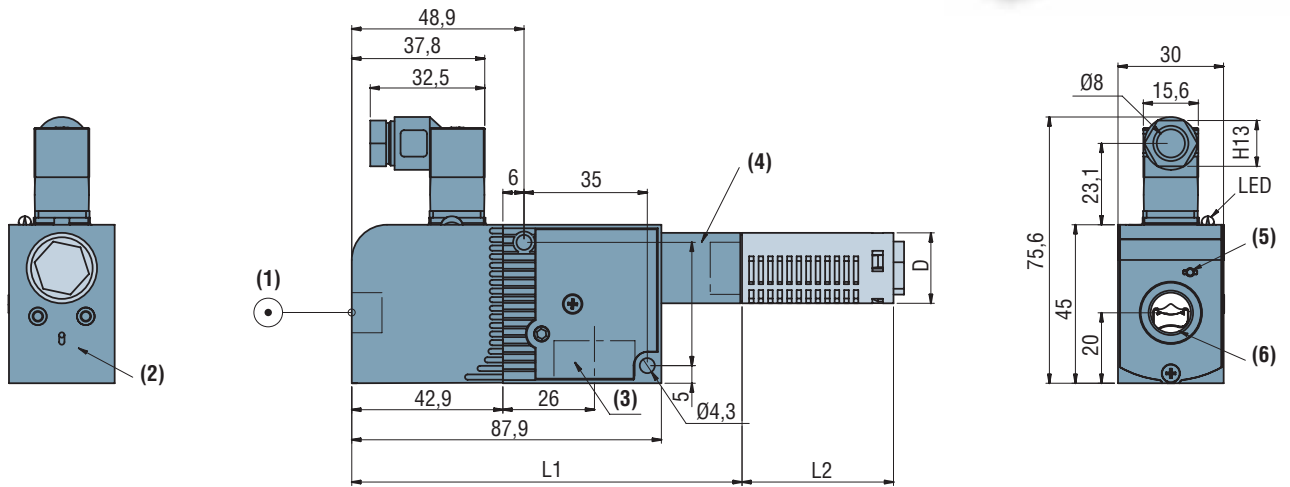

- (1) 4 bar compressed air tank
- (2) Vacuum switch option mounting zone
- (3) Vacuum 1/2 Gas
- (4) Exhaust
- (5) Manual controls
- (6) 1/4 Gas (push fitting supplied for 6 x 8 version)

models	D (mm)		D1 (Gas)		L1 ⁽¹⁾ (mm)		L2 (mm)		
	X	N/T	X	N/T	X	N/T	S	K(N/T)	K(X)
GVPS 12	30	20	1/2	1/4	105.95	110.8	45	68	121
GVPS 15	30	20	1/2	1/4	105.95	120.95	45	68	121
GVPS 20	30	30	1/2	1/2	105.95	105.95	60	121	121
GVPS 25	30	30	1/2	1/2	105.95	105.95	60	121	121
GVPS 30	30	30	1/2	1/2	177.75	177.75	-	121	121

(1) L1 with standard silencer (S).

Additional information

Options

- Vacuum switches see page 8/16.
- Other options see pages 8/17 and 8/18.

Curves

See page 8/19.



Branch-specific applications

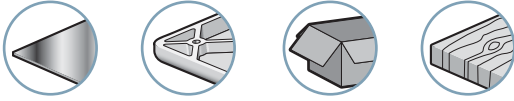

Description

GVPD series vacuum pumps control vacuum generation and blow-off (adjustable flow). Controlling the force and duration of blow-off accelerates gripping/release rates, cleans objects before gripping and improves releasing process for large diameter suction pads.

Advantages

- Integrated electric vacuum and blow-off control
- Can be adapted to all branches
- Optimized performance for handling all types of objects
- Reduced wiring and easy-to-use
- Modular design thanks to the different options
- Light and compact
- No clogging thanks to the through type silencer
- Silent operation

Characteristics

model	Ø nozzle (mm)	air consumed (Nl/min)	maximum vacuum (%)			air drawn in (Nl/min)		
			X	T	N	X	T	N
GVPD 12	1.2	67	40	75	90	150	63	45
GVPD 15	1.5	100	50	75	90	180	95	70
GVPD 20	2	180	50	75	90	250	160	125
GVPD 25	2.5	270	50	75	90	360	240	200
GVPD 30	3	400	50	75	90	450	330	265

As standard, versions N and T are delivered with silencer S and version X with silencer K. Only exception, the GVPD 30 is fitted with silencer K.

Evacuation time in seconds per liter

% vacuum	10			20			30			40			50			60			70			80			85		
versions	X	T	N	X	T	N	X	T	N	X	T	N	X	T	N	X	T	N	X	T	N	X	T	N	X	T	N
GVPD 12	0.05	0.10	0.14	0.11	0.22	0.30	0.22	0.37	0.49	0.62	0.55	0.71	-	0.78	0.97	-	1.16	1.33	-	1.92	1.81	-	-	2.66	-	-	3.42
GVPD 15	0.04	0.07	0.09	0.09	0.15	0.20	0.15	0.24	0.32	0.27	0.36	0.46	-	0.52	0.63	-	0.77	0.85	-	1.27	1.16	-	-	1.71	-	-	2.20
GVPD 20	0.03	0.04	0.06	0.06	0.09	0.12	0.11	0.14	0.19	0.19	0.22	0.28	-	0.31	0.38	-	0.46	0.52	-	0.76	0.71	-	-	1.04	-	-	2.13
GVPD 25	0.02	0.03	0.03	0.04	0.06	0.07	0.08	0.10	0.11	0.14	0.14	0.16	-	0.21	0.22	-	0.30	0.30	-	0.50	0.41	-	-	0.60	-	-	0.77
GVPD 30	0.01	0.02	0.02	0.03	0.04	0.05	0.06	0.07	0.08	0.11	0.10	0.12	-	0.15	0.17	-	0.22	0.23	-	0.37	0.31	-	-	0.45	-	-	0.58

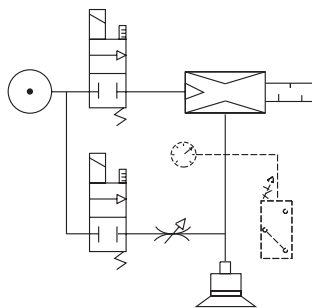

Specifications

Supply	Non-lubricated filtered air, 2 to 6 bar
Optimum pressure	4 bar
Voltage	24 V DC
Power	0.7 W
Material	POM - 2017A - Cu Zn - PA6 15% FG
Temperature	0 to 60 °C / 32 to 140°F
Number of valve operations	10 million
Operating frequency	Maximum 2 Hz
Function	N.C. (N.O. on request)

For all orders, please specify:

Model + Nozzle diameter + Characteristic + Silencer + Fitting + Control

1: Model	2: Nozzle diameter	3: Characteristic	4: Silencer	5: C.A. fitting	6: Controls
GVPD	12 1.2mm 15 1.5mm 20 2mm 25 2.5mm 30 3mm	X 50% vacuum T 75% vacuum N 90% vacuum	- Without silencer S ⁽¹⁾ Diffuser K Through-type	14 1/4 G BSPP	E1 24V DC N.C. E other voltages on request

(1) no silencer (S) for nozzle Ø 30.

E.g. GVPD 25 N K 14 E1

(GVPD series vacuum pump, nozzle diameter 2.5mm, 90% vacuum with through type silencer, 1/4 gas pressure fitting and 24V DC N.C. control)

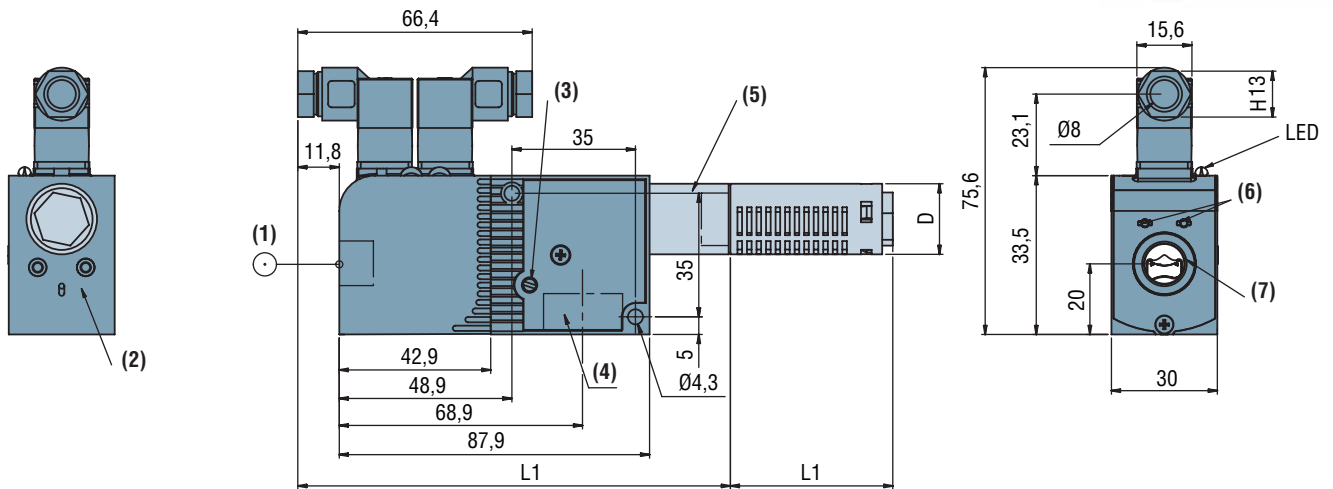

- (1) 4 bar compressed air tank
- (2) Vacuum switch option mounting zone
- (3) Blow-off adjustment
- (4) Vacuum 1/2 Gas
- (5) Exhaust
- (6) Manual control
- (7) 1/4 Gas (push fitting supplied for 6 x 8 version)

models	D (mm)		D1 (Gas)		L1 ⁽¹⁾ (mm)		L2 (mm)		
	X	N/T	X	N/T	X	N/T	S	K(N/T)	K(X)
GVPD 12	30	20	1/2	1/4	140.6	145.45	45	68	121
GVPD 15	30	20	1/2	1/4	140.6	155.6	45	68	121
GVPD 20	30	30	1/2	1/2	140.6	140.6	60	121	121
GVPD 25	30	30	1/2	1/2	140.6	140.6	60	121	121
GVPD 30	30	30	1/2	1/2	212.4	212.4	-	121	121

(1) L1 with standard silencer (S).

Additional information

Options

- Vacuum switches see page 8/16.
- Other options see pages 8/17 and 8/18.

Curves

See page 8/19.



Branch-specific applications



Advantages

- Safety guaranteed by check valves
- Ideal for handling air-tight objects
- Optimized performance for handling all types of objects
- Reduced wiring and easy-to-use
- Modular design thanks to the different options
- Light and compact
- No clogging thanks to the through type silencer
- Silent operation

Description

GVS series vacuum pumps are commonly known as safety vacuum pumps. Like the GVPD series pumps, they integrate vacuum generation and blow-off (adjustable flow). In addition, two safety check valves hermetically blank off the vacuum circuit in the event of failure of either of the two power sources (electric and/or pneumatic) thus ensuring that object(s) remain gripped. Caution: Objects to be handled must be air-tight.

Characteristics

model	Ø nozzle (mm)	air consumed (Nl/min)	max. vacuum (%) N	air drawn in (Nl/min)
GVS 12	1.2	67	90	45
GVS 15	1.5	100	90	70
GVS 20	2	180	90	125
GVS 25	2.5	270	90	200
GVS 30	3	400	90	265

Evacuation time in seconds per liter

% vacuum	10	20	30	40	50	60	70	80	85
versions	N	N	N	N	N	N	N	N	N
GVS 12	0.14	0.30	0.49	0.71	0.97	1.33	1.81	2.66	3.42
GVS 15	0.09	0.20	0.32	0.46	0.63	0.85	1.16	1.71	2.20
GVS 20	0.06	0.12	0.19	0.28	0.38	0.52	0.71	1.04	2.13
GVS 25	0.03	0.07	0.11	0.16	0.22	0.30	0.41	0.60	0.77
GVS 30	0.02	0.05	0.08	0.12	0.17	0.23	0.31	0.45	0.58

Specifications

Supply	Non-lubricated filtered air, 2 to 6 bar
Optimum pressure	4 bar
Voltage	24 V DC
Power	0.7 W
Material	POM - 2017A – Cu Zn – PA6 15% FV
Number of valve operations	15 million
Operating frequency	Maximum 2 Hz
Maximum speed	less than 20 cycles per minute
Valve function	N.C.
	N.O. in 24V DC on request

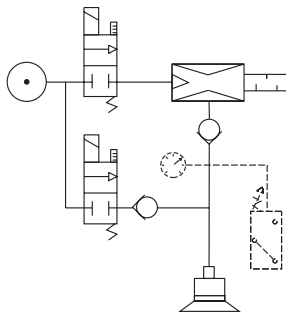

For all orders, please specify:

Model + Nozzle diameter + Characteristic + Silencer + Fitting + Control

1: Model	2: Nozzle diameter	3: Characteristic	4: Silencer	5: C.A. fitting	6: Controls
GVS	12 1.2mm 15 1.5mm 20 2mm 25 2.5mm 30 3mm	N 90% vacuum	- Without silencer S ⁽¹⁾ Diffuser K Through-type	14 1/4 G BSPP	E1 24 V DC N.F. E other voltages on request

(1) no silencer (S) for nozzle Ø 30.

E.g. GVS 15 N K 68 E1

(GVS series safety vacuum pump, nozzle diameter 1.5mm, 90% vacuum with through type silencer, 6x8 calibrated tube fitting and 24V DC NC electric control)

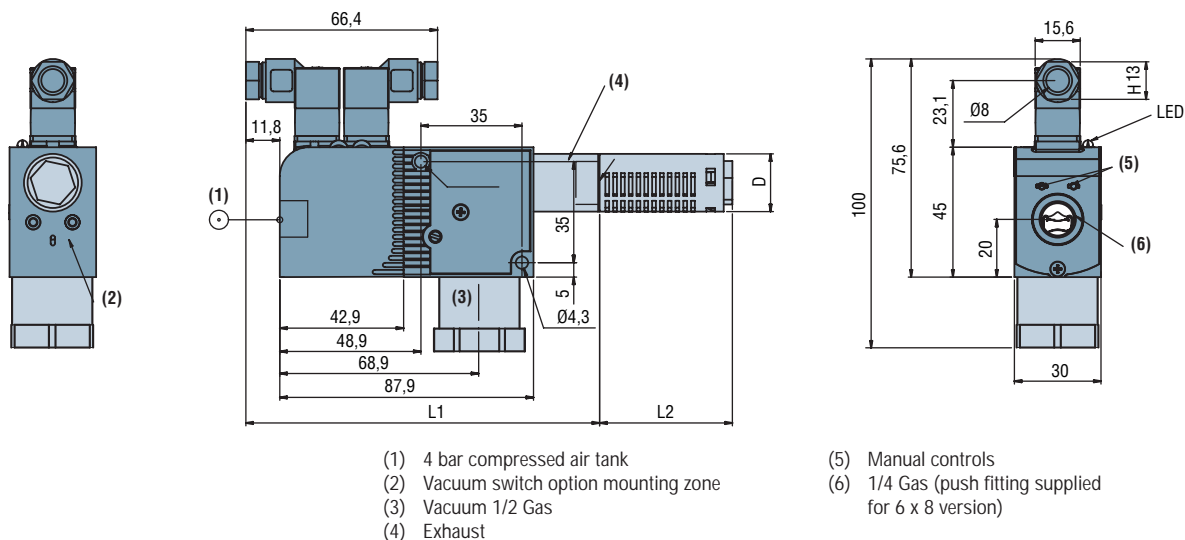

models	D	D1	L1 ⁽¹⁾	L2	
	(mm)	(Gas)	(mm)	(mm)	(mm)
	N/T	N/T	N/T	S	K
GVS 12	20	1/4	157.2	45	68
GVS 15	20	1/4	167.2	45	68
GVS 20	30	1/2	167.2	60	121
GVS 25	30	1/2	167.2	60	121
GVS 30	30	1/2	300.2	-	121

(1) L1 with standard silencer (S).

Additional information

Options

■ Vacuum switch options (see pages 8/16).

Curves

See page 8/19.



Branch-specific applications



Advantages

- Safety guaranteed by check valves
- Ideal for handling air-tight objects
- Optimized performance for handling all types of objects
- Reduced wiring and easy-to-use
- Modular design thanks to the different options
- Light and compact
- No clogging thanks to the through type silencer
- Silent operation

Description

GVS series vacuum pumps are commonly known as safety vacuum pumps. Like the GVPD series pumps, they integrate vacuum generation and blow-off (adjustable flow). In addition, two safety check valves hermetically blank off the vacuum circuit in the event of failure of the pneumatic power source, thus ensuring that object(s) remain gripped. Caution: Objects to be handled must be air-tight.

Characteristics

model	Ø nozzle (mm)	air consumed (Nl/min)	max. vacuum (%) N	air drawn in (Nl/min)
GVS 12	1.2	67	90	45
GVS 15	1.5	100	90	70
GVS 20	2	180	90	125
GVS 25	2.5	270	90	200
GVS 30	3	400	90	265

Evacuation time in seconds per liter

% vacuum	10	20	30	40	50	60	70	80	85
versions	N	N	N	N	N	N	N	N	N
GVS 12	0.14	0.30	0.49	0.71	0.97	1.33	1.81	2.66	3.42
GVS 15	0.09	0.20	0.32	0.46	0.63	0.85	1.16	1.71	2.20
GVS 20	0.06	0.12	0.19	0.28	0.38	0.52	0.71	1.04	2.13
GVS 25	0.03	0.07	0.11	0.16	0.22	0.30	0.41	0.60	0.77
GVS 30	0.02	0.05	0.08	0.12	0.17	0.23	0.31	0.45	0.58

Specifications

Supply	Non-lubricated filtered air, 2 to 6 bar
Optimum pressure	4 bar
Voltage	24V DC
Power	0.7 W
Material	POM - 2017A – Cu Zn – PA6 15% FV
Number of valve operations	15 million
Operating frequency	Maximum 2 Hz
Maximum speed	less than 20 cycles per minute

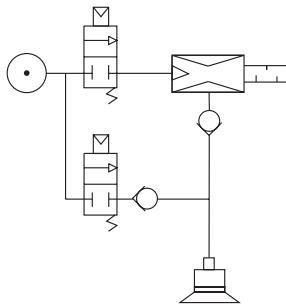

For all orders, please specify:

Model + Nozzle diameter + Characteristic + Silencer + Fitting + Control

1: Model	2: Nozzle diameter	3: Characteristic	4: Silencer	5: C.A. fitting	6: Controls
GVS	12 1.2mm 15 1.5mm 20 2mm 25 2.5mm 30 3mm	N 90% vacuum	- Without silencer S ⁽¹⁾ Diffuser K Through-type	14 1/4 G BSPP 68 6x8 calibrated tube	P1 pneumatic

(1) no silencer (S) for nozzle Ø 30.

E.g. GVS 15 N K 68 P1

(GVS series safety vacuum pump, nozzle diameter 1.5mm, 90% vacuum with through type silencer, 6x8 calibrated tube fitting and pneumatic control)

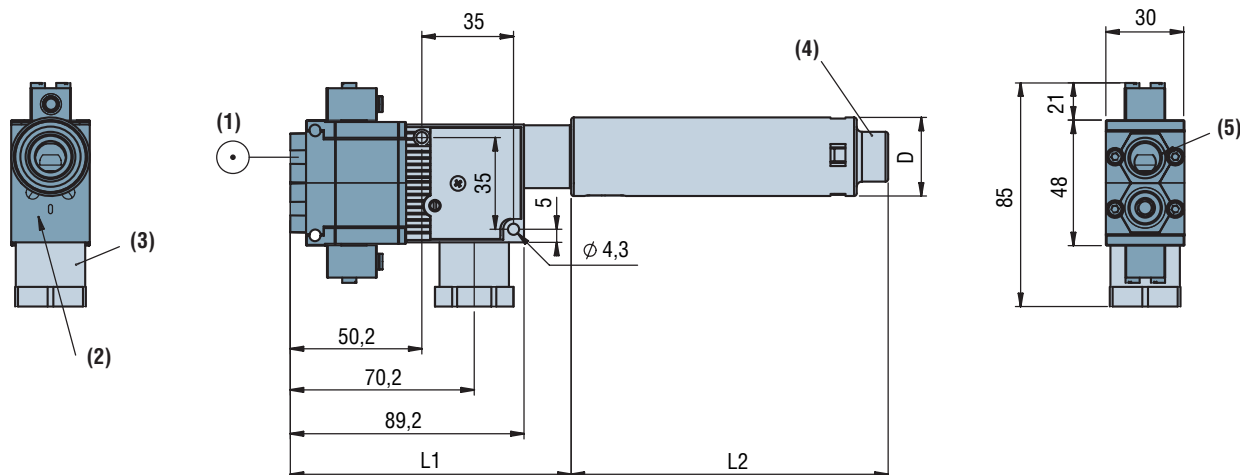

- (1) 4 bar compressed air tank
- (2) Vacuum switch option mounting zone
- (3) Vacuum 1/2 Gas
- (4) Exhaust
- (5) 1/4 Gas

models	D	D1	L1 ⁽¹⁾	L2	
	(mm)	(Gas)	(mm)	(mm)	(mm)
	N/T	N/T	N/T	S	K
GVS 12	20	1/4	157.2	45	68
GVS 15	20	1/4	167.2	45	68
GVS 20	30	1/2	167.2	60	121
GVS 25	30	1/2	167.2	60	121
GVS 30	30	1/2	300.2	-	121

(1) L1 with standard silencer (S).

Additional information

Options

- Vacuum switches see page 8/16.
- Other options see pages 8/17 and 8/18.

Curves

See page 8/19.

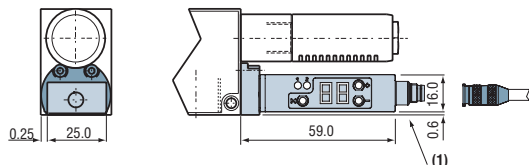

Delivered with M8 cable (2 meters)
(1) M8 connector

Electronic vacuum switch with display

GVO PSA 100 C option

(See exact characteristics page 12/1)

Our top-of-the-range electronic vacuum switch, the PSA 100, has an LED display showing the vacuum value in different units. It also has two separate outputs with independently regulated hysteresis, N.O. or N.C.

- PNP as standard
- M8 connector.
- Connection cable, see page 8/20.

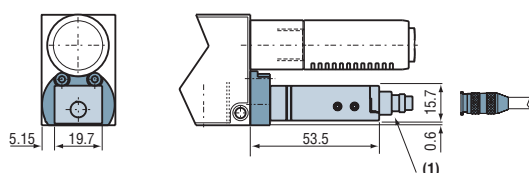

Delivered with M8 cable (2 meters)
(1) M8 4 pole connector

Electronic vacuum switch

GVO PSP 100 C (M5), PSP 100 L (M5) option

(See characteristics page 12/2)

The vacuum data collected is always very reliable even with a large number of suction pads, thanks to the precision of the PSP 100. It has one output with hysteresis adjustment.

- PNP as standard
- M8 connector
- Connection cable, see page 8/20.

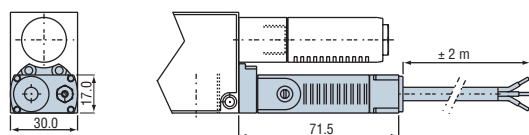

GVO PSE 100 E with cable (length 2 metres)

Vacuum switch with electrical signal

GVO PSE 100 E or EC option

(See characteristics page 12/3)

The PSE 100 E or EC vacuum switch indicates the level of vacuum in the suction pad circuit. For a small number of suction pads (5 to 10 maximum). This indication is enough to prove an object is gripped. Hysteresis (125mbar) must also be taken into account according to the use of the vacuum switch data.

Check that the vacuum pump supply pressure generates a level of pressure equal to the threshold setting.

For connection cable, see page 8/20.

(Connector with LED available to display vacuum switch status).

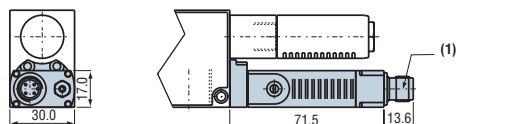

GVO PSE 100 EC with M12 connector (delivered without connection cable)

(1) M12 male connector

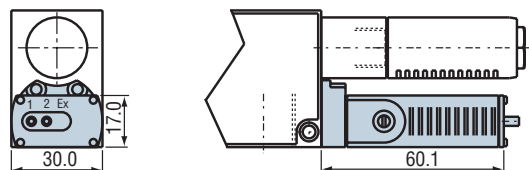

Vacuum switch with pneumatic signal

GVO PSE 100 P N.O. or N.C. option

(see characteristics page 12/4)

For use in fully pneumatic applications or explosive environments. The vacuum switch enables a pressure data message to be given when a vacuum threshold is reached.

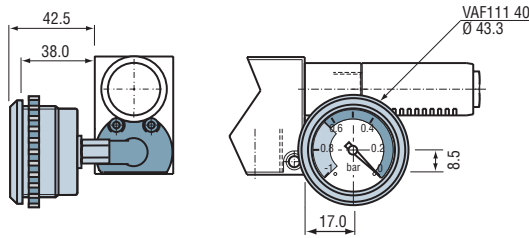

Vacuum gauge

GVO VAF 111 40 option

(See characteristics page 12/6)

The vacuum gauge displays the level of vacuum in the suction pad circuit. This option makes it simple to keep the status of the vacuum circuit under constant surveillance.

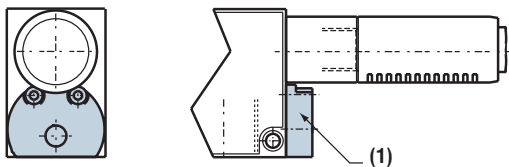

(1) Plug

Plug to shut off vacuum data

GVOB option

This plug option makes it possible to shut off the vacuum signal to avoid affecting operation of the vacuum pump if a GVO option is removed.

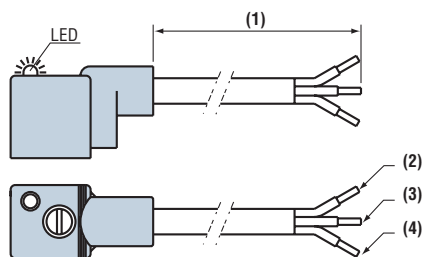

- (1) L(2 meters)
- (2) Brown
- (3) Blue
- (4) Yellow-Green (Earth)

GVO CA 24 V option, (110 V or 220 V on request)

with anti-interference on electric valve control: factory-mounted.

Use of an anti-interference is recommended on the valve control when using electrically-controlled pumps. This anti-interference protects the equipment and ensures the valve control is reliable in electrically polluted environments.

- As standard for 24V DC and CA control
- On request for other models

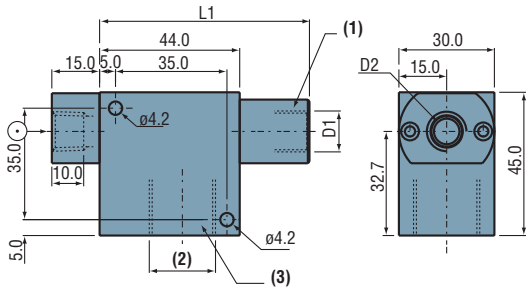

GVO AL and GVO AL NPT option (for GVP vacuum pump)

Body and flange 1/4 Gas in aluminum.

■ Note: It is no longer possible to mount vacuum gauge options.

- | | |
|---|-------------|
| L1 = L1 GVP (plastic) - 1mm | (1) Exhaust |
| D1 = D1 (GVP N, T and X) | (2) 1/2 Gas |
| D2 = 1/4 Gas for GVO AL
1/4 NPT for GVO AL NPT | (3) Vacuum |

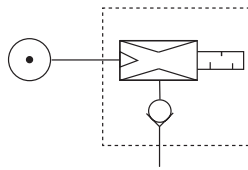

Check valve option - Ref. 02090101 (for GVPD vacuum pump)

Check valve option.

Requires blow-off downstream from the valve for release.

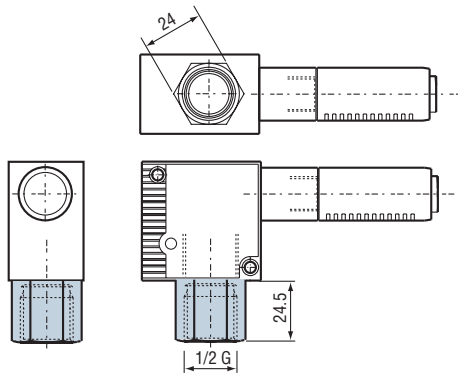

GVO P option

with 1/2 protective extension

The 1/2 extension is recommended for double valve models or with pneumatic vacuum switch to protect components during mounting or installation.

The extension is fitted with a 400 micron stainless steel filtration grid as standard.

Curves for modular vacuum pumps

■ Pressure 4 bar

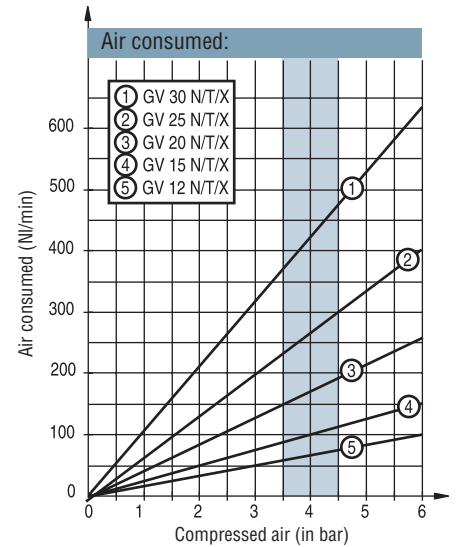
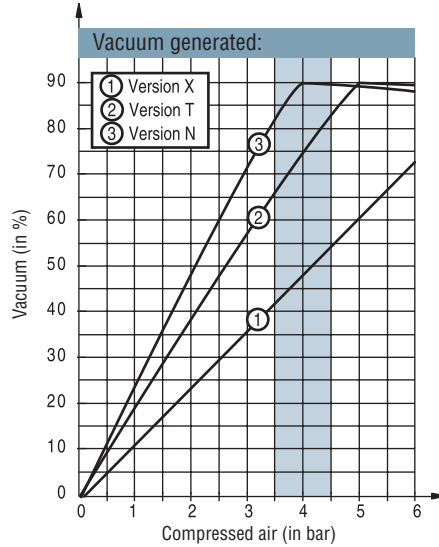

Version X - 50% vacuum

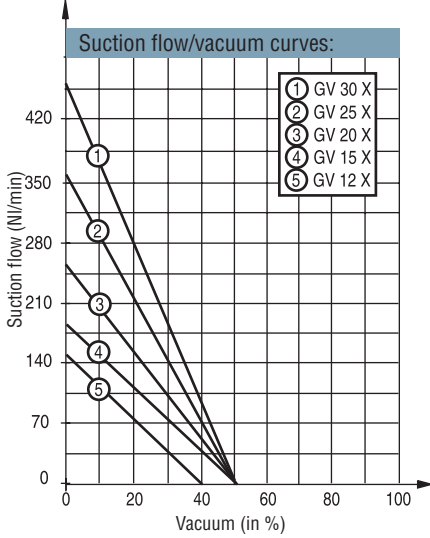

■ Supply pressure 4 bar
Version T - 75% vacuum

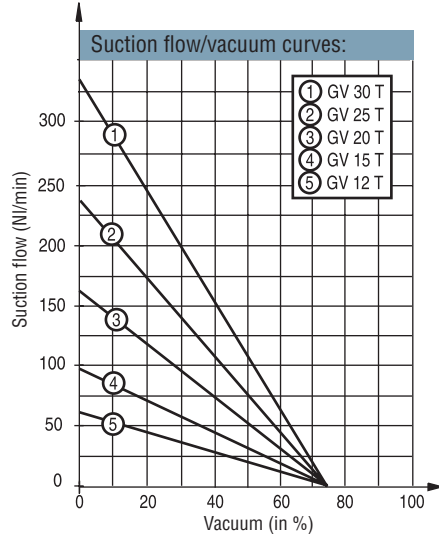

Version N - 90% vacuum

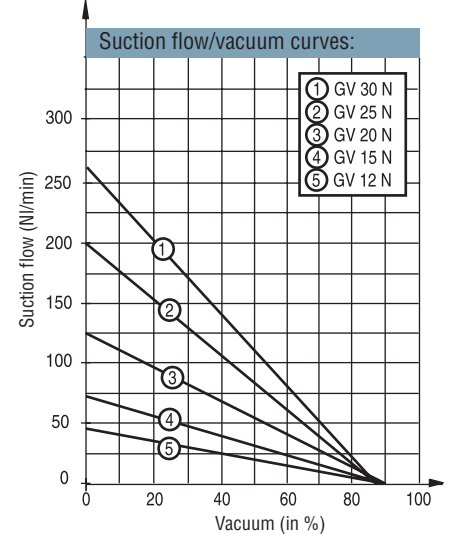

■ Supply pressure 4 bar
Version T - 75% vacuum

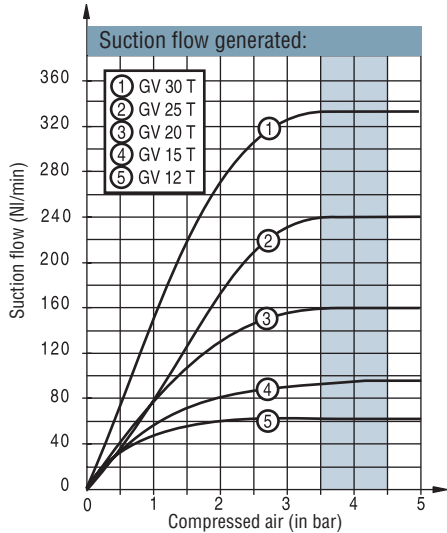

Version N - 90% vacuum

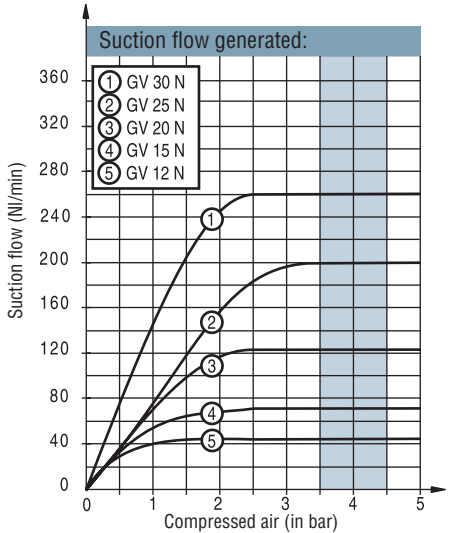

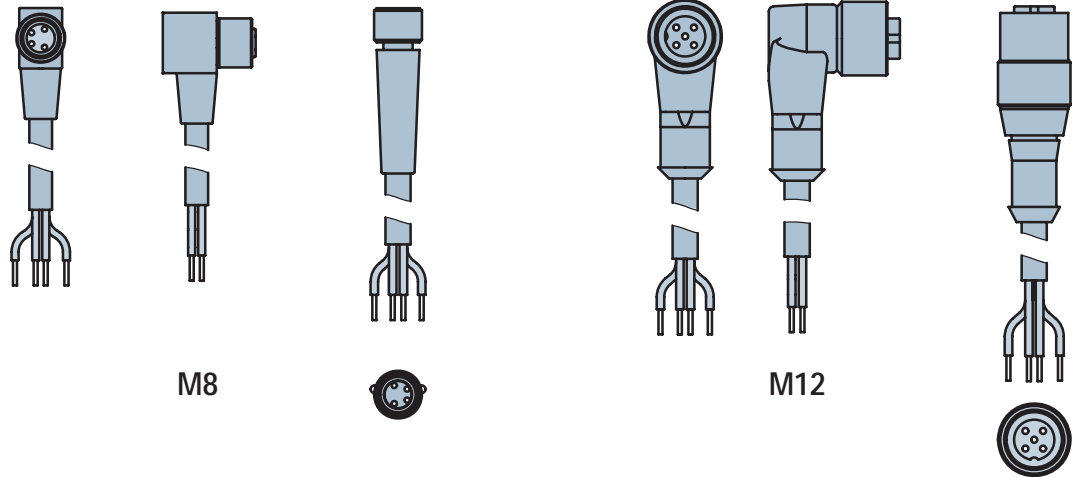

M8

M12

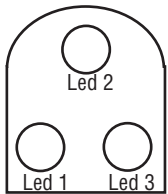

- Led 1: orange, NO/NC outlet depending on wiring
- Led 2: orange, NC/NO outlet depending on wiring
- Led 3: green, Vacuum switch is energized (10-30 V)

M12 connector for PSE 100 EC vacuum switch

- Straight connector, reference CD M12.
- Elbow connector, reference CC M12.
- Elbow connector with LED reference CC M12 to display if the vacuum threshold set on the vacuum switch has been reached or not (PNP model - Opening and closure - 3 LEDs).

M8 connector for electronic vacuum switches PSA 100 C and PSL 100

- Straight connector, reference CD M8.
 - Elbow connector, reference CC M8.
- These connectors can also be used for the PSL 100, PSL 100 M5, PSA 100 C series of vacuum switches.

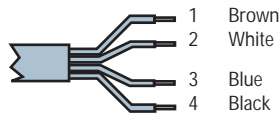

Specifications

- Female connector.
- PVC cable, length 2 meters, 4 strands, overmoulded.
- Connector wiring.
- Protection: IP 65

On request

- PUR cable, 5 or 10 meters.

For all orders, please specify: Model + Type of connector + Fitting + LED

1: Model	2 : Type of connector	3: Fitting	4: LED
C	D straight connector	M12 for M12 male	- without LED
	C elbow connector	M8 for M8 male	L with LED for CC M12 connector

E.g. CC M12 L
(Elbow connector for M12 male with LED).

GEM

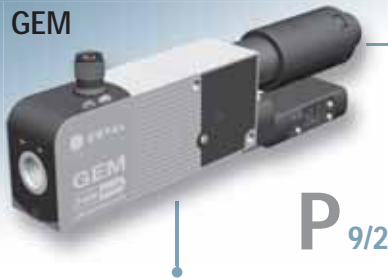

P_{9/2}

- Coval's "all in one" innovative solution
- Over 50 % of energy saved
- Noise levels reduced by up to 30dBa
- Modular design thanks to the different options
- Reduced wiring
- Reduced installation time
- No clogging
- Optimized performance for handling all types of objects
- Can be adapted to all branches

- Integrated energy-saving vacuum pumps
- Nozzle Ø 1.2 ; 1.5 ; 2.0 ; 2.5 ; 3mm
- 2 levels of vacuum: 60% and 90%

- All the functions required integrated in the product
- Integrated pressure regulator
- Integrated M12 connection (Plug &Play)

GEMP

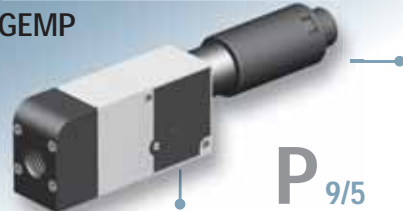

P_{9/5}

- Very compact and light-weight
- Ideal for all applications requiring an outside pressure regulator
- Exceptional energy savings thanks to automatic pressure regulation at 4 bar
- Optimal performances
- Silent operation
- No clogging

- Simple energy-saving vacuum pumps
- Nozzle Ø 1.2 ; 1.5 ; 2.0 ; 2.5 ; 3mm
- 2 levels of vacuum: 60% and 90%
- Suction rate between 150 and 450 NI/min
- Integrated supply pressure regulation
- Integrated silencer

GVMAX



P_{9/10}

- Compact and light
- Ideal for retaining air-tight objects in the automotive, plastics and sheet metal industries
- Energy saved by the vacuum regulation function
- Safety guaranteed in case of power failure
- Optimal performances
- Silent operation
- No clogging

- Self-regulating vacuum pumps
- Electric or pneumatic controls
- Nozzle Ø: 2.5 mm
- Three levels of vacuum: 50%, 75% and 90%
- Vacuum regulation function

- Integrated vacuum solenoid valves and and blow-off
- 2 integrated check valves for pneumatic version and 1 for electric version
- Integrated vacuum switch to adjust the vacuum threshold and hysteresis
- Integrated silencer

GVMAX V2/V2R



P_{9/12}

- Compact and light
- Ideal for retaining air-tight objects in the automotive, plastics and sheet metal industries
- Energy saved by the vacuum regulation function
- Safety guaranteed in case of power failure
- Optimal performances
- Silent operation
- No clogging

- Self-regulating vacuum pumps
- Electric vacuum and blow-off controls
- Nozzle Ø: 2.5 mm
- Maximum vacuum level 90%
- Vacuum regulation function
- Integrated vacuum solenoid valves and and blow-off
- Integrated vacuum check-valve

GVMAX V3



P_{9/14}

- Compact and light
- Ideal for retaining air-tight objects in the automotive, plastics and sheet metal industries
- Energy saved by the vacuum regulation function
- Safety guaranteed in case of power failure
- Optimal performances
- Silent operation
- No clogging

- Self-regulating vacuum pumps
- Electric vacuum and blow-off controls
- Integral blow-off
- Integrated pressure regulator
- Nozzle Ø: 3mm
- Maximum vacuum level 90%
- Vacuum regulation function
- Integrated vacuum solenoid valves and blow-off
- Integrated vacuum check-valve

GVE



P_{9/16}

- Compact and light
- Ideal for explosive environments and tank emptying applications
- Optimized performance
- Safety guaranteed by the vacuum retaining check valve
- Energy saved by the vacuum regulation function
- Silent operation
- No clogging

- Self-regulating vacuum pumps
- Pneumatic vacuum control
- Nozzle Ø 1.2 ; 1.5 ; 2.0 ; 2.5 ; 3mm
- Suction flow between 150 and 450 NI/min
- 3 levels of vacuum: 50 %, 75% and 90%
- Pneumatic vacuum valve and integrated control
- Integrated vacuum check-valve
- Integrated vacuum switch for the vacuum threshold
- Integrated silencer

GEM series

twin tech™

Integrated energy-saving vacuum pumps



Branch-specific applications

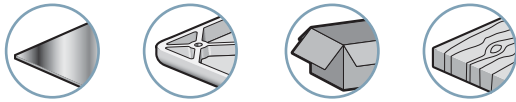

Advantages

- "All-in-one" solution, no more peripherals to be added.
- Simplified installation and use thanks to the Plug & Play system
- Over 50% of energy saved
- Noise levels reduced by up to 30dBA
- Modular design thanks to the different options
- Controlled or timed blow-off
- No clogging thanks to the through type silencer
- Light and compact
- Optimized performance for handling all types of objects
- Can be adapted to all branches

twin tech™

A new perspective
in industrial vacuum
technology

ivc

Integrated Vacuum Control
Integrated solenoid control

A traditional single or multi-stage vacuum pump must be fitted with the numerous peripheral modules required for it to operate: solenoid control, control valve and electronic circuit, supply pressure regulator, vacuum switch and blow-off valve, which lead to increased dimensions, weight, complex wiring and additional cost of the overall vacuum system.

The patented COVAL IVC technology makes it possible to integrate all the necessary functions into a single compact and light-weight module.

The installation is drastically simplified: no need to select, order and install additional peripheral modules as it comes in a ready to use plug & play format.

ipr

Intelligent Pressure Regulation
Optimum operation and minimum consumption of compressed air

Even in multi-stage versions, traditional vacuum pumps are noisy and use a lot of compressed air. With IPR technology the problem is solved.

The internal intelligence of the GEM vacuum pumps constantly combines operation of the integrated regulator with that of the venturi profile whatever the pressure in the supply network.

The unique combination of the pressure regulator and venturi reduces both the sound level and the energy consumption significantly.

Presentation

The GEM series vacuum pumps integrate Coval's Twintech™ technology, a combination of two innovative technologies: IPR (intelligent pressure regulation) and IVC (integrated vacuum control). GEM series pumps provide an "all-in-one" solution integrating all the required functions, such as pressure regulation, controls, valves, vacuum switch and silencer in a single compact module.

The M12 connection radically simplifies installation and usage. GEM series pumps are available with two levels of vacuum, 60% and 90%, and five nozzle diameters (1.2 ; 1.5 ; 2.0 ; 2.5 et 3.0 mm).

Characteristics

- Supply: non-lubricated filtered air, 5 microns according to standard ISO 8573-1 class 4.
- Protection level: IP65.
- Optimum operating pressure: 4 to 8 bar.
- Blow-off: - network supply pressure,
- adjustable flow.
- Control voltage: 24V DC (regulated), ±10%.
- Current consumed: 30mA (0.7 W) vacuum or blow-off.
- Maximum operating frequency: 2Hz.
- Number of operations: 10million cycles.
- Materials: PA 6-6 15% fiber glass, POM, PC 15%, fiber glass, brass, aluminum, NBR.
- Operating temperature: 10 to 60°C / 50 to 140°F.

model	Ø nozzle (mm)	air consumed (NI/mn)	maximum-vacuum(%)	air drawn in (NI/mn)	at air pressure (bar)
GEM60	1.2	65	60	72	4
GEM60	1.5	97	60	110	4
GEM60	2.0	179	60	189	4
GEM60	2.5	200	60	275	4
GEM60	3.0	385	60	385	4
GEM90	1.2	65	90	50	4
GEM90	1.5	97	90	75	4
GEM90	2.0	179	90	125	4
GEM90	2.5	260	90	200	4
GEM90	3.0	385	90	245	4

Evacuation time in seconds per liter

% vacuum	10	20	30	40	50	60	70	80	85
GEM60x12	0.09	0.2	0.35	0.55	0.9	-	-	-	-
GEM60x15	0.06	0.14	0.23	0.36	0.59	-	-	-	-
GEM60x20	0.04	0.08	0.13	0.21	0.34	-	-	-	-
GEM60x25	0.03	0.05	0.09	0.14	0.24	-	-	-	-
GEM60x30	0.01	0.04	0.07	0.10	0.17	-	-	-	-
GEM90x12	0.13	0.27	0.44	0.64	0.88	1.19	1.62	2.37	3.12
GEM90x15	0.09	0.18	0.29	0.42	0.58	0.79	1.08	1.59	2.08
GEM90x20	0.05	0.11	0.18	0.25	0.35	0.46	0.65	0.95	1.25
GEM90x25	0.03	0.07	0.11	0.16	0.22	0.3	0.41	0.59	0.78
GEM90x30	0.03	0.06	0.09	0.13	0.18	0.24	0.33	0.48	0.64



Circuit diagrams

Simple vacuum pump without blow-off

GEM_X_RV_

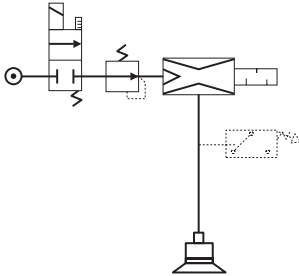

- the simplest configuration.
- a single control signal.

Vacuum pump with controlled blow-off

GEM_X_SV_

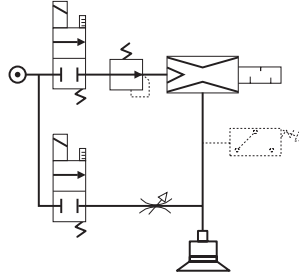

- blow-off controlled by external signal, with flow adjustment screw.
- 2 control signals.

Vacuum pump with automatic, timed blow-off

GEM_X_TV_

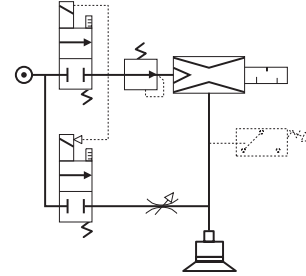

- blow-off controlled by stopping the vacuum pump and maintained for an adjustable period of 0 to 3s, with flow adjustment screw.
- a single control signal.

M12 electrical connection

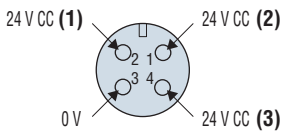

- (1) vacuum control
- (2) permanent (version T)
- (3) blow-off control (version S)

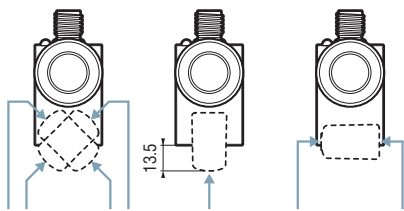

choice of 7 positions for a fully accessible front panel

Vacuum switches

- Modules with electronic indexable vacuum switch **GEM...VA** with display, 2 outlets: see page 12/1

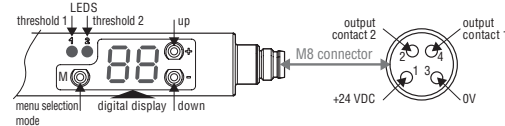

- **GEM...VB** 1 outlet: see page 12/2

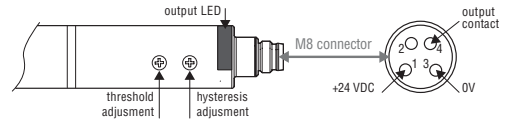

- Modules with electrical contact vacuum switch **GEM...VC**: see page 12/3

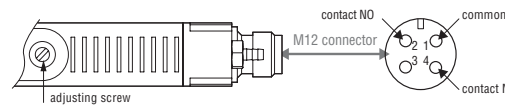

- Modules without vacuum switch **GEM...VO**: this model must be completed with an independent vacuum switch on the vacuum circuit or a vacuum gauge for vacuum in a manually controlled capacity.

For all orders, please specify:

Model + Vacuum level + X + Nozzle diameter + Module composition + Vacuum switch

1: Model	2: Vacuum level	X	3: Nozzle diameter	4: Composition of the module	5: Vacuum switches
GEM	60 max. 60% vacuum (porous objects)		12 Ø 1.2mm	R simple, without blow-off	VA electronic display
	90 max. 90% vacuum (air-tight objects)		15 Ø 1.5mm	S with controlled blow-off	VB electronic
			20 Ø 2mm	T with automatic, timed blow-off	VC with electrical contact
			25 Ø 2.5mm		VO without vacuum switch
			30 Ø 3mm		

E.g. GEM 90X12SVA

(GEM vacuum pump, maximum vacuum 90%, nozzle diameter 1.2mm, controlled blow-off and electronic vacuum switch with display)

GEM series

Dimensions Curves



- (A) M12 connector
- (1) silencer for nozzles
Ø 1.2 or 1.5mm
(GEM--X12--, GEM--X15--)
- (2) silencer for nozzles
Ø 2 - 2.5 or 3mm
(GEM--X20--, GEM--X25--, GEM--X30--)
- (3) manual vacuum and blow-off controls
- (4) fittings Ø 4.2mm
- (5) blow-off flow adjustment

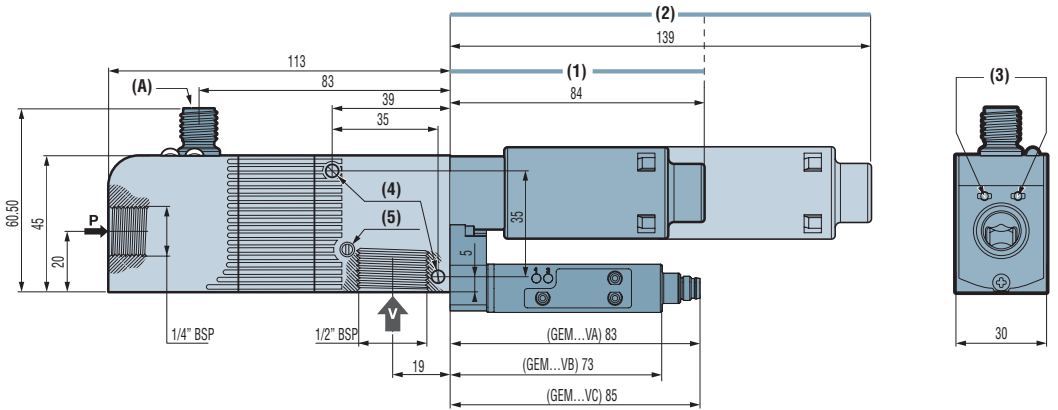

Curves

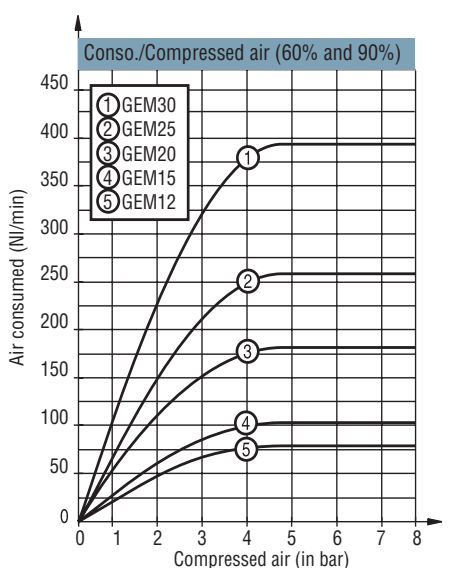
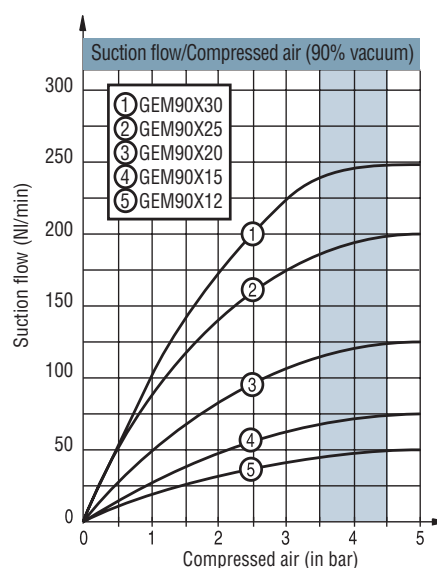
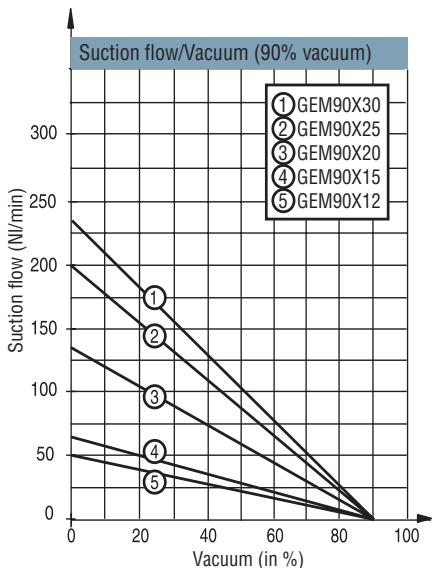
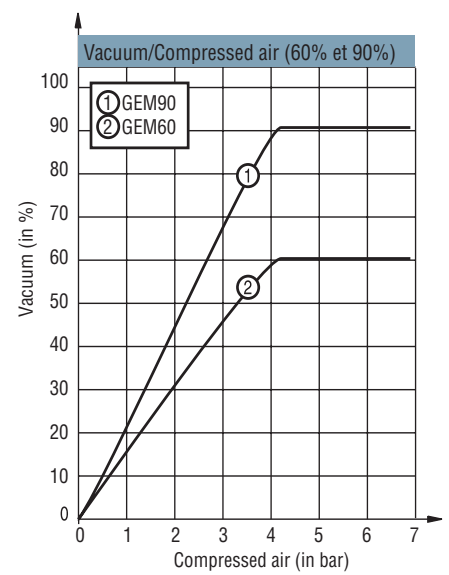
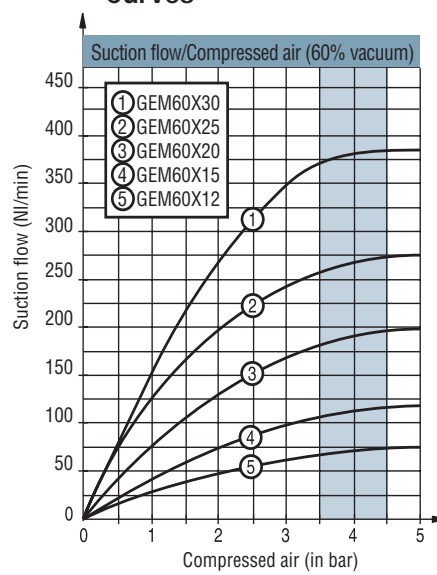
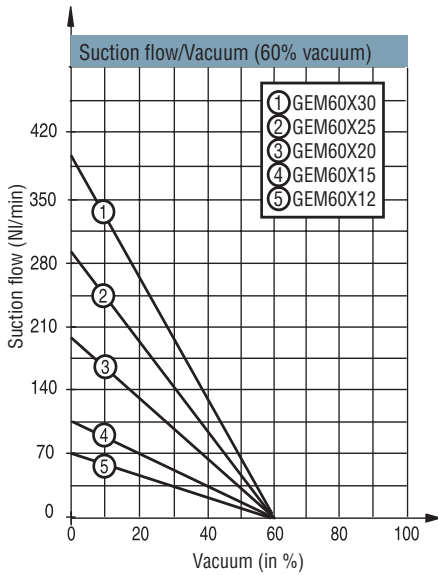



Branch-specific applications

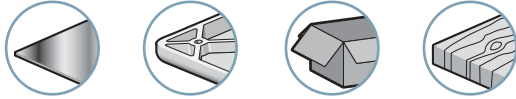

Description

The GEMP series vacuum pumps are the simplest in the energy-saving range. They can regulate the supply pressure automatically to an optimum pressure of 4 bar thanks to an integrated pressure regulator whatever the pressure in the compressed air network, and this without penalizing other applications which require more than 4 bar.

GEMP pumps therefore reduce both energy consumption and the noise level.

Advantages

- Modular design thanks to the different options
- Compact and light
- Exceptional energy savings
- Optimized performances for all types of applications
- Silent operation
- No clogging

Characteristics

model	Ø nozzle (mm)	air consumed (NI/mn)	maximum-vacuum(%)	air drawn in (NI/mn)	at air pressure (bar)
GEMP60	1.2	65	60	72	4
GEMP60	1.5	97	60	110	4
GEMP60	2.0	179	60	189	4
GEMP60	2.5	200	60	275	4
GEMP60	3.0	385	60	385	4
GEMP90	1.2	65	90	50	4
GEMP90	1.5	97	90	75	4
GEMP90	2.0	179	90	125	4
GEMP90	2.5	260	90	200	4
GEMP90	3.0	385	90	245	4

Evacuation time in seconds per liter

% vacuum	10	20	30	40	50	60	70	80	85
GEMP60x12	0.09	0.2	0.35	0.55	0.9	-	-	-	-
GEMP60x15	0.06	0.14	0.23	0.36	0.59	-	-	-	-
GEMP60x20	0.04	0.08	0.13	0.21	0.34	-	-	-	-
GEMP60x25	0.03	0.05	0.09	0.14	0.24	-	-	-	-
GEMP60x30	0.01	0.04	0.07	0.10	0.17	-	-	-	-
GEMP90x12	0.13	0.27	0.44	0.64	0.88	1.19	1.62	2.37	3.12
GEMP90x15	0.09	0.18	0.29	0.42	0.58	0.79	1.08	1.59	2.08
GEMP90x20	0.05	0.11	0.18	0.25	0.35	0.46	0.65	0.95	1.25
GEMP90x25	0.03	0.07	0.11	0.16	0.22	0.3	0.41	0.59	0.78
GEMP90x30	0.03	0.06	0.09	0.13	0.18	0.24	0.33	0.48	0.64

Vacuum switch characteristics

- See page 9/3.

Specifications

Supply	Non-lubricated filtered air, 2 to 8 bar
Optimum pressure	4 bar
Weight	100 to 265 g
Material	POM - 2017A – Cu Zn – PA6 15% FG
Operating temperature	-10 to 80 °C / 14 to 176°F

For all orders, please specify: Model + Vacuum level + X + Nozzle diameter + Vacuum switch

1: Model	2: Vacuum level	X	3: Nozzle diameter	4: Vacuum switches
GEMP	60 max. 60% vacuum (porous objects) 90 max. 90% vacuum (air-tight objects)		12 Ø 1.2mm 15 Ø 1.5mm 20 Ø 2mm 25 Ø 2.5mm 30 Ø 3mm	VA electronic display VB electronic VC with electrical contact VO without vacuum switch

E.g. GEMP 90 X 12 VASFIb(GEMP vacuum pump, maximum 90% vacuum, nozzle diameter 1.2mm, with electronic vacuum switch with display)



- (1) silencer for nozzles
Ø 1.2 or 1.5mm
(GEMP--X12--, GEMP--X15--)
- (2) silencer for nozzles
Ø 2 - 2.5 or 3mm
(GEMP--X20--, GEMP--X25--,
GEMP--X30--)
- (3) fittings Ø 4.2mm
- (4) 1/4G pressure fitting:
pressure at 4 bar
- (5) 1/2G vacuum fitting

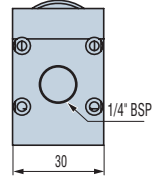
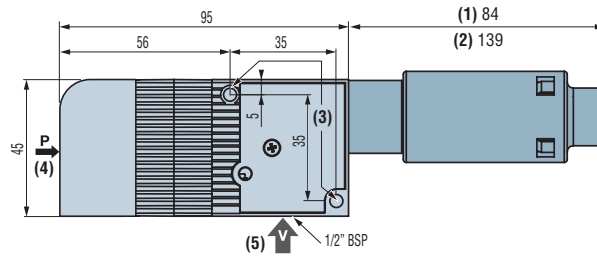

Curves

- see curves for the GEM series page 9/4.

Description

COVAL's innovative GVMAX and GVE series of pumps are designed for gripping, handling and retaining air-tight objects.

The principle is simple: as soon as the required level of vacuum is reached, the compressed air supply is stopped and the vacuum is maintained in the installation thanks to the check valve. Thus, the self-regulating system guarantees an optimum level of vacuum.

This approach considerably reduces both compressed air consumption and the noise level. Moreover, thanks to their intelligent functions, they guarantee safety and optimum vacuum management for the application. COVAL recommends these pumps for applications involving air-tight objects.

The specific functions of air-saving, vacuum-regulating vacuum pumps

They have the following characteristics:

- Vacuum generation by venturi effect (maximum pressure drop - 900mbar or 90% vacuum).
- Air-saving, vacuum-regulating function.
- Adjustable blow-off.
- Visual and switching output control of vacuum level by digital electronic vacuum switch.
- Positive safety holds objects in case of electrical emergency stop (electrical outlets switched off) via its NO vacuum supply valve, maintenance can be carried out in complete safety.

Operating principle of a GVMAX series vacuum pump

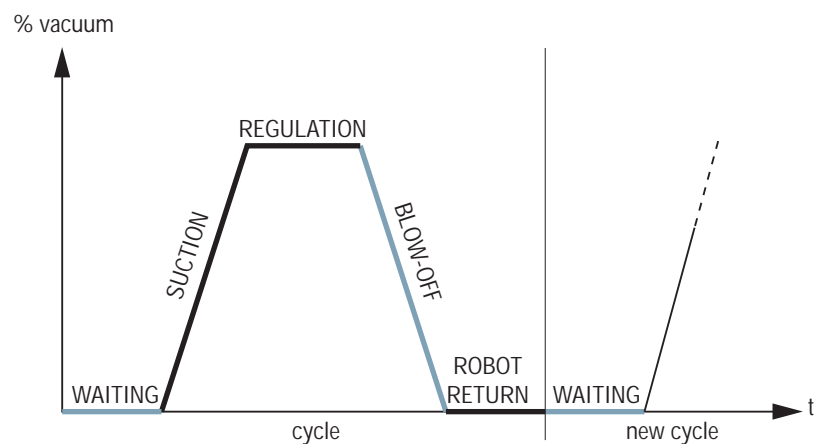

The cycle shows the three stages of a GVMAX: Waiting - Suction - Blow-off.

Regulation is automatically performed by the equipment's internal loop. The interest of the GVMAX vacuum pump is based on these three stages:

- Waiting: no consumption, no clogging, no noise.
- Suction-regulation: the object is gripped and the vacuum pump automatically stops.
- Blow-off: automatically timed for release and return to neutral position in readiness for the next cycle.

Note: in addition to silent operation and energy savings, status 1 allows to perform the operation without an upstream solenoid valve cutting off the air inlet in "waiting" mode.

Regulating system in an air-saving vacuum pump

The GVMAX vacuum pump is designed to save compressed air during a gripping cycle. The equipment stops consuming compressed air when the vacuum threshold pre-set in the vacuum switch is reached in the network. This is known as "regulation".

The curve below shows the regulating system of a vacuum pump. As soon as optimum vacuum (vacuum threshold 1) is reached, the pumps maintain the vacuum until the level of vacuum descends to the hysteresis value after a period of time "t" due to leakage.

The self-regulating system guarantees that an optimum level of vacuum is maintained and reduces both air consumption and the noise level throughout the cycle.

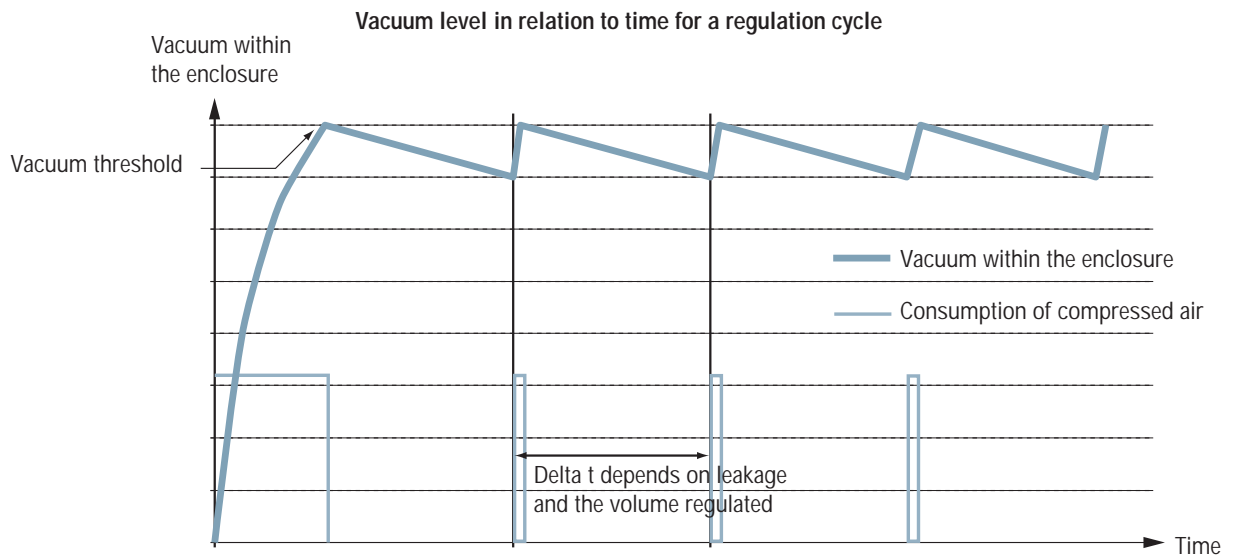

GVMAX vacuum pump yield

Volume of air consumed and time to create a vacuum in a 5 liter tank with a 4 bar GVMAX vacuum pump:

vacuum (%)	time to create a vacuum (s)	air consumed (NI)
10	0.2	0.9
20	0.3	1.8
30	0.6	2.9
40	0.8	4.2
50	1.1	5.9
60	1.5	7.8
70	2.1	10.9
80	3.0	15.7
85	4.0	21.0

During the final phase of manufacture a snowboard must be held in position for many minutes. Using vacuum pumps with air-saving function generates significant energy savings.

Holding

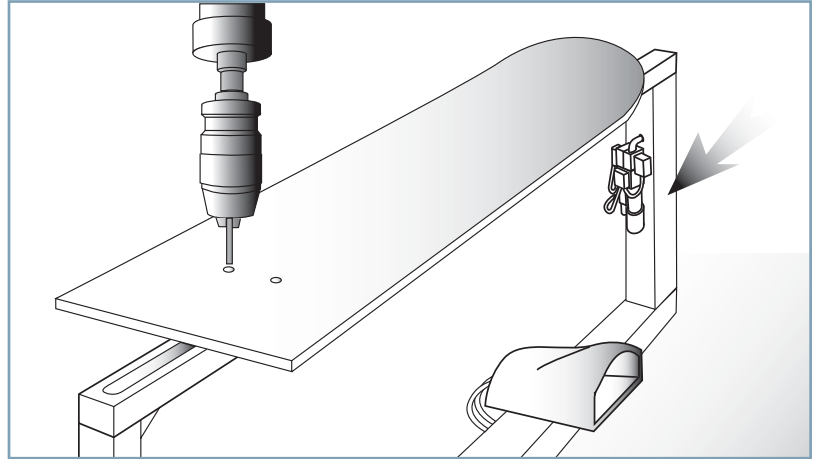

The regulation function of the vacuum pumps are used in this type of application. Hysteresis of the switching output regulation is adjustable between 1 and 25% vacuum on electric models.

Emptying a tank

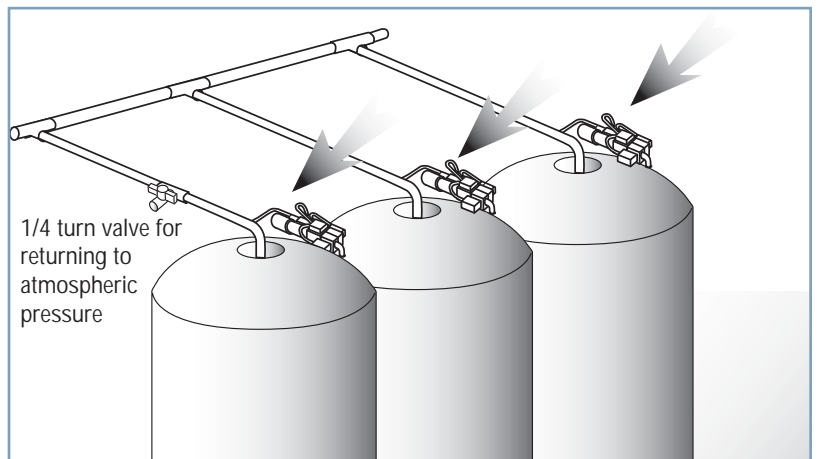

Note: For regulation of the vacuum level in tanks of more than 10 liters, consult us for the pneumatic versions.

■ Electric GVMAX

Grip is maintained on the object (air-tight object) if there is a power failure.

■ Pneumatic GVMAX

Grip is maintained on the object (air-tight object) if the pneumatic power is interrupted.

Grip is maintained safely

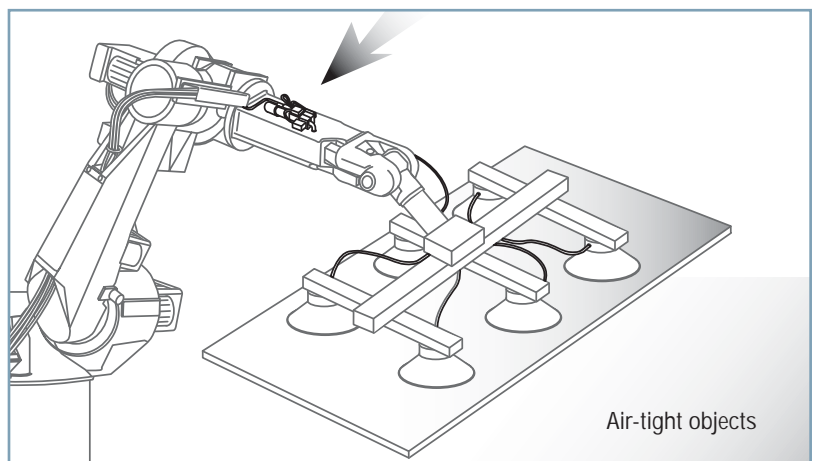

Grip is maintained if the electrical power or compressed air supply is interrupted.



(electric vacuum control and blow-off)

Branch-specific applications



Safety

The GVMAX E1 has a check valve installed as standard which enables it to maintain the vacuum within the circuit if there is a power failure. This function guarantees maximum safety conditions for operators during handling.

Materials

Similar to GEM (see page 9/2).

Description

The communication between both elements, electronic vacuum switch and gripping valve control allows the consumption of compressed air to be regulated and in particular significantly reduced. This range of vacuum pumps is strongly recommended for gripping air-tight objects, holding and for medium or long cycles. Electrically controllable blow-off is integrated for release.

Characteristics

model	Ø nozzle (mm)	max. vacuum (%)			air drawn in (NI/min)			L2 (mm)		⚖ (g)
		X	T	N	X	T	N	S	K ⁽¹⁾	
GVMAX E1	2.5	50	75	90	360	240	200	60	121	510

(1) delivered as standard on version X.

Evacuation time in seconds per liter

% vacuum versions	Ø nozzle (mm)	10			20			30			35			40			45			50			60			70			80			85		
		X	T	N	X	T	N	X	T	N	X	X	T	N	X	T	N	T	N	T	N	T	N	T	N	N	N	N	N					
GVMAX E1	2.5	0.02	0.03	0.03	0.04	0.06	0.07	0.08	0.10	0.11	0.01	0.14	0.14	0.16	0.19	0.21	0.22	0.30	0.30	0.50	0.41	0.60	0.77											

Operating principle

When the selected vacuum level is reached, the compressed air supply stops. This interruption does not have any effect as the check valve maintains the vacuum and thus the grip. The vacuum switch continually analyzes the vacuum requirements. As soon as the minimum threshold is reached, it actuates the vacuum generation valve to return to the pre-set value.

Specifications

Supply	Non-lubricated filtered air, 2 to 6 bar, optimum at 4 bar
Temperature	0 to 60 °C / 32 to 140°F
Contact output	PNP all-or-nothing NO or NC, adjustable hysteresis
Anti-parasite function	Integrated with display LED
Suction rate	Adjusted by flow restrictor

Curves: see page 9/13

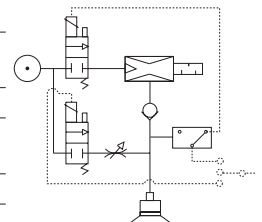

Dimensions

- (1) LED gripping display
- (2) Compressed air inlet
- (3) LED blow-off display
- (4) Vacuum 1/2 Gas
- (5) PSA100C vacuum switch
- (6) 1/4 Gas, fast 6x8
- (7) White: Contact output
- (8) Brown: 24V DC (gripping)
- (9) Blue: common
- (10) Black: 24V DC (blow-off)

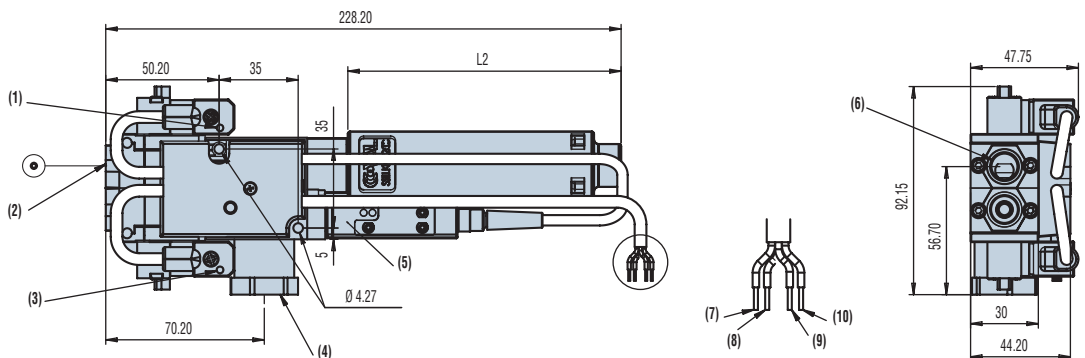

For all orders, please specify: Model + Characteristic + Silencer + C.A. fitting + E1

1: Model	2: Characteristic	3: Silencer	4: C.A. fitting	E1
GVMAX	X 50% vacuum T 75% vacuum N 90% vacuum	- Without silencer S Diffuser K Through-type	14 1/4 G BSPP 68 6x8 calibrated tube	

E.g. GVMAX T K 68 E1

(GVMAX vacuum pump with electric self-regulation, 75% vacuum with through type silencer and C.A. fitting 6x8 calibrated tube)



(pneumatic vacuum and blow-off control)

Branch-specific applications



Safety

The GVMAX P1 has two check valve functions installed as standard which enables it to maintain the vacuum within the circuit if the pneumatic power is interrupted. This function guarantees maximum safety conditions for operators during handling.

Materials

Similar to GEM (see page 9/2).

Description

The communication between both elements, pneumatic vacuum switch and gripping valve control allows the consumption of compressed air to be regulated and in particular significantly reduced. This range of vacuum pumps is strongly recommended for gripping air-tight objects, holding and for medium or long cycles in explosive environments. Pneumatically controllable blow-off is integrated for release.

Note: The volume of the piping must not exceed 10 liters. For higher volumes, please consult us.

Characteristics

model	Ø nozzle (mm)	max. vacuum (%)			air drawn in (Nl/min)			L2 (mm)		⊞ (g)
		X	T	N	X	T	N	S	K ⁽¹⁾	
GVMAX P1	2.5	50	75	90	360	240	200	60	121	440

(1) delivered as standard on version X.

Evacuation time in seconds per liter

% vacuum versions	Ø nozzle (mm)	10			20			30			35			40			45			50		60		70		80		85	
		X	T	N	X	T	N	X	T	N	X	X	T	N	X	T	N	T	N	T	N	T	N	N	N	N	N		
GVMAX P1	2.5	0.02	0.03	0.03	0.04	0.06	0.07	0.08	0.10	0.11	0.01	0.14	0.14	0.16	0.19	0.21	0.22	0.30	0.30	0.50	0.41	0.60	0.60	0.77					

Operating principle

When the selected vacuum level is reached, the compressed air supply stops. This interruption does not have any effect on the current operation as the check valve maintains the vacuum and thus the grip. The vacuum switch continually analyzes the vacuum requirements. As soon as the minimum threshold is reached, it actuates vacuum generation valve. The chosen level of vacuum is immediately re-established.

Note: to ensure optimum operation, we advise you to ensure the vacuum network is air-tight. For this purpose we recommend using NVS vacuum feeders and screwed vacuum fittings with O-rings (RDV, RCOV).

Specifications

Supply	Non-lubricated filtered air, 2 to 6 bar, optimum at 4 bar
Temperature	0 to 60 °C / 32 to 140 °F
Vacuum switch	PSE100PKNO
Pressure at the vacuum switch	Equal to or greater than vacuum pump's supply pressure
Hysteresis	100mbar max.

Curves: see page 9/13

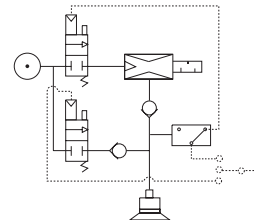

Dimensions

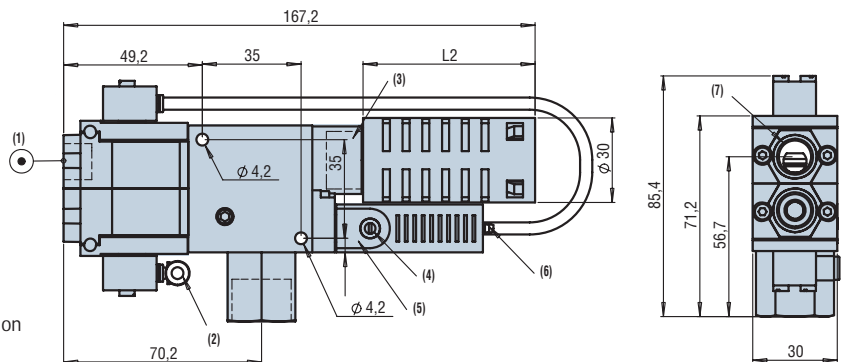

- (1) 5.5 bar compressed air inlet
- (2) Fast 2.7x4 blow-off control
- (3) 1/2 Gas Exhaust
- (4) Regulation threshold adjustment
- (5) PSE100PKNO vacuum switch
- (6) Hollow shaft for vacuum control vacuum switch pressurisation
- (7) 1/4 Gas, fast 6x8

For all orders, please specify: Model + Characteristic + Silencer + C.A. fitting + P1

1: Model	2: Characteristic	3: Silencer	4: C.A. fitting	P1
GVMAX	X 50% vacuum	- Without silencer	14 1/4 G BSPP	
	T 75% vacuum	S Diffuser	68 6x8 calibrated tube	
	N 90% vacuum	K Through-type		

E.g. GVMAX T K 68 P1

(GVMAX vacuum pump with pneumatic self-regulation, 75% vacuum with through type silencer and C.A. fitting, 6x8 calibrated tube)

Branch-specific applications

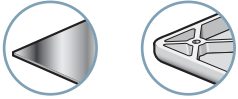

Description

With GVMAXSP345 V2 and GVMAX SP345 V2R, COVAL offers two types of solutions based on a standard GVMAX electric vacuum pump. The GVMAXSP345V2 type vacuum pump is fitted with the non-adjustable PSA 100BU vacuum switch (factory set) and GVMAXSP345V2R regulated vacuum pump fitted with the PSA 100B adjustable vacuum switch.

Characteristics

model	Ø nozzle (mm)	maximum vacuum (%)	flow consumed at 4 bar (NI/s)	max. suction power (NI/min)	dynamic supply pressure	⊞ (g)
GVMAX SP345V2	2.5	90	4.5	200	4 bar relative pressure	550
GVMAX SP345V2R	2.5	90	4.5	200	4 bar relative pressure	550

Applications

The two solutions, GVMAX SP345 V2 and GVMAX SP345V2R are used for gripping air-tight objects in the stamping, sheet-metal/bodywork and mounting industries for handling, transfer and holding operations. The GVMAXSP345 V2/V2R is designed for the Automotive sector.

Evacuation time in seconds per liter

Model	Ø nozzle (mm)	10	20	30	40	50	60	70	80	85
GVMAX V2/V2R	2.5	0.03	0.07	0.11	0.16	0.22	0.30	0.41	0.60	0.77

Electrical connections

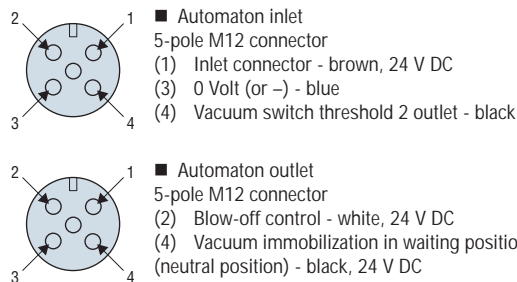

- Pneumatic supply maintained on the "compressed air" inlet of the vacuum pump.
- Electric power supply Suction: 24V DC N.O. solenoid valve. From rest to suction (must be powered to stop suction). Blow-off: 24V DC N.C. solenoid valve

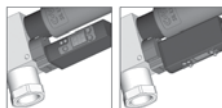
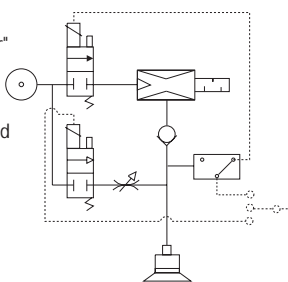

Red LED Green LED

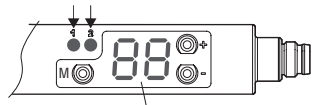

2 digit display in % vacuum (e.g. 75 for 75% vacuum)

Advantages

In relation to the standard GVMAX, the GVMAX SP345 V2 and GVMAX SP345 V2R solutions offer the following advantages:

- Safety: vacuum generation in case of power failure by air inlet solenoid valve in normally open operation (24 V DC).
- Powerful, controllable blow-off.
- Data processing circuit (connection cable)
- Connection by 2 male 5 pin M12 connectors, (Input/ Output)
- Non-adjustable vacuum switch (factory-set) with the GVMAX SP345 V2 and adjustable vacuum switch with the GVMAX SP345 V2R.

Specifications

Base body	Aluminum (AU 4 PB)
Valve body	POM (black polyacetal)
Silencer	Black PC with felt internal element
Vacuum switch	PA66, PC, brass, NBR seal
Electric wiring	PA66
Screw	Zinc-plated steel
Inside parts	Brass; Aluminum; Desmopan
Seals	NBR
Membrane	NBR with nylon substrate

Vacuum switch display legibility

The GVMAX is fitted with an indexable vacuum switch (45°, 90°, 180°). This vacuum switch is set to the following values (values used in the automotive industry):

GVMAX SP345 V2 or V2R	Function	Threshold	Hysteresis
Threshold 1: vacuum regulation	NO	H1: 75 %	h1: 10 %
Threshold 2: object detected	NO	H2: 65 %	h2: 10 %

For all orders, please specify:

GVMAX SP345 V2 (Non-adjustable vacuum switch)

GVMAX SP345 V2R (Adjustable vacuum switch)



Dimensions

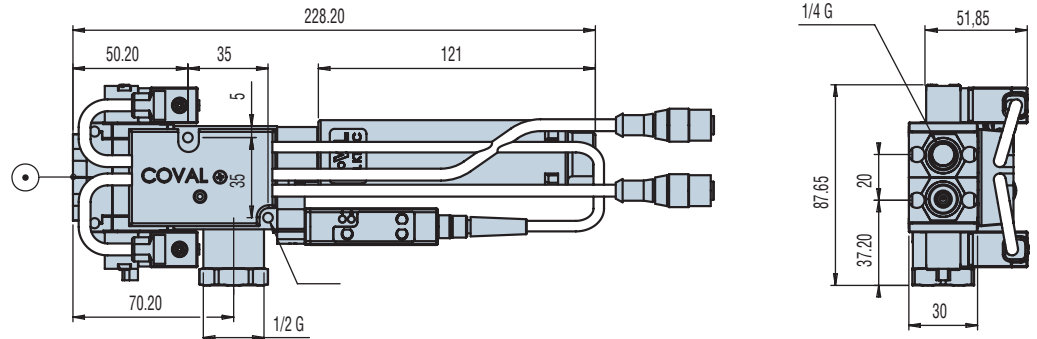

Curves

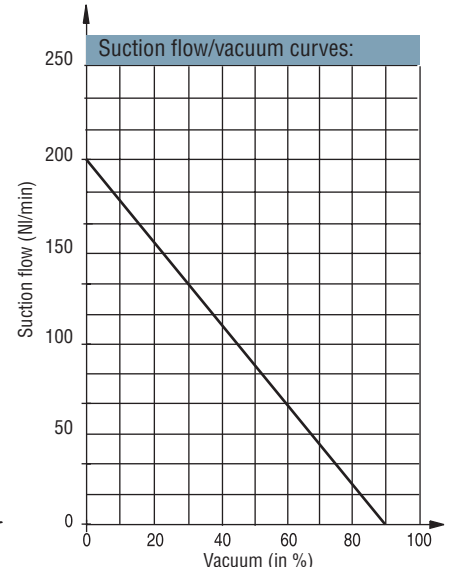
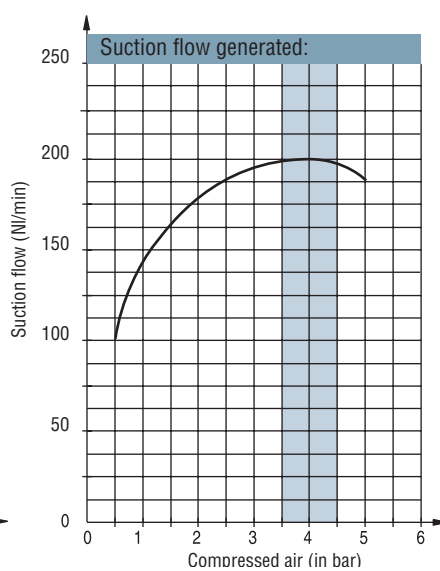
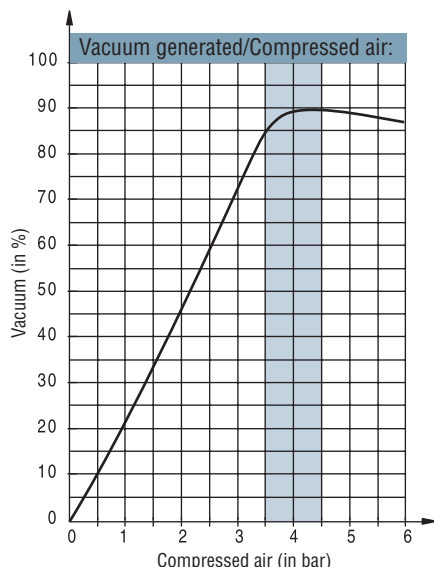

GVMAX SP 345V2 B4



GVOMAXV2

Options

■ Manifold mounting

The GVMAXSP345V2 and V2R can also be manifold-mounted.

Up to 4 vacuum pumps can be installed on one base.

Manifold references (example with GVMAX SP 345 V2)

GVMAX SP 345V2 B1 (Base + 1 x GVMAX SP 345V2)

GVMAX SP 345V2 B2 (Base + 2 x GVMAX SP 345V2)

GVMAX SP 345V2 B3 (Base + 3 x GVMAX SP 345V2)

GVMAX SP 345V2 B4 (Base + 4 x GVMAX SP 345V2)

■ Protective housing for GVMAX, ref. GVOMAXV2

The protective housing for the GVMAX is transparent and removable. Coval recommends using a protective housing to protect the vacuum pump.

GVMAX V3 series



Special self-regulating vacuum pumps

(electric vacuum and blow-off control)

Branch-specific applications

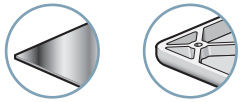

Applications

The two solutions, GVMAX SP345V3 and GVMAX SP345V3R are used for gripping air-tight objects in the stamping, sheet-metal/bodywork and mounting industries for handling, transfer and holding operations. The GVMAX SP345V3 was designed and developed for the Automotive sector.

Presentation

The GVMAXSP345V3 series vacuum pumps include Coval's Twintech™ technology⁽¹⁾, a combination of two innovative technologies: IPR (intelligent pressure regulation) and IVC (integrated vacuum control). GVMAX series pumps provide an "all-in-one" solution integrating all the required functions, such as pressure regulators, controls, valves, vacuum regulation, powerful integrated blow-off, Object presence detection by vacuum switch and silencer in a single compact, light-weight module.

The M12 connections dramatically simplify installation and use. They are available in two versions:

- GVMAXSP345V3: non-adjustable vacuum switch (factory configured)
- GVMAXSP345V3R: adjustable vacuum switch

(1) Twintech: for detailed information see page 9/2.

Characteristics

model	Ø nozzle (mm)	maximum vacuum (%)	flow consumed at 4 bar (NI/s)	max. suction flow (NI/min)	dynamic supply pressure	⚖ (g)
GVMAX SP345V3/V3R	3	90	6.4	245	5 bar relative pressure	450

Evacuation time in seconds per liter

Model	nozzle Ø (mm)	10	20	30	40	50	60	70	80	85
GVMAX SP345V3/V3R	3	0.03	0.06	0.09	0.13	0.18	0.24	0.33	0.48	0.64

Electrical connections

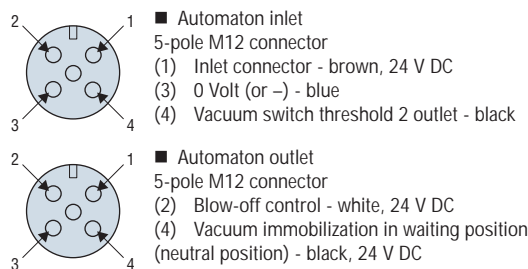

■ Pneumatic supply maintained on the "compressed air" inlet of the vacuum pump.

■ Electric power supply, Suction: 24V DC N.O. solenoid valve. From rest to suction (must be powered to stop suction). Blow-off: 24V DC N.C.

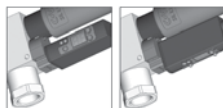
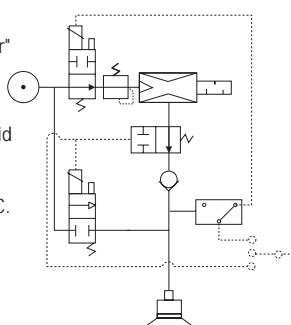

Red LED Green LED

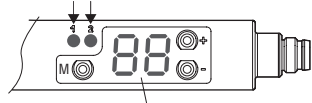

2 digit display in % vacuum (e.g. 75 for 75% vacuum)

Advantages

- Safety: vacuum generation in case of power failure by air inlet solenoid valve in normally open operation (24 V DC).
- Strong suction reduces time to create a vacuum.
- Powerful, controllable integral blow-off.
- Data processing circuit (connection cable)
- Connection by 2 male 5 pin M12 connectors, (Input/ Output)
- Integrated pressure regulator.
- Silent operation
- Non-adjustable vacuum switch with the GVMAX SP345 V3 and adjustable vacuum switch with the GVMAX SP345 V3R.
- In case of interruption in the network supply pressure, the vacuum network is brought to atmosphere.

Specifications

Base body	Aluminum (AU 4 PB)
Valve body	POM (black polyacetal)
Silencer	Black PC with felt internal element
Vacuum switch	PA66, PC, brass, NBR seal
Electric wiring	PA66
Screw	Zinc-plated steel
Inside parts	Brass; Aluminum; Desmopan
Seals	NBR
Membrane	NBR with nylon substrate
Protection level	IP 65

Vacuum switch display legibility

The GVMAX is fitted with an indexable vacuum switch (45°, 90°, 180°). This vacuum switch is set to the following values (values used in the automotive industry): 65% (object present) and 75% (regulation).

For all orders, please specify:

GVMAX SP345 V3 (Non-adjustable vacuum switch)

GVMAX SP345 V3R (Adjustable vacuum switch)



Dimensions

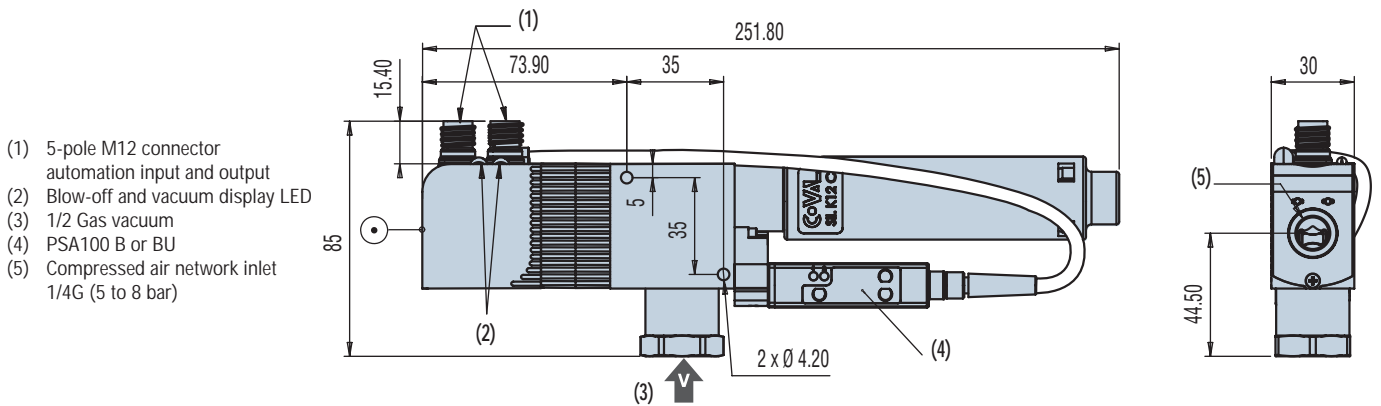

Curves

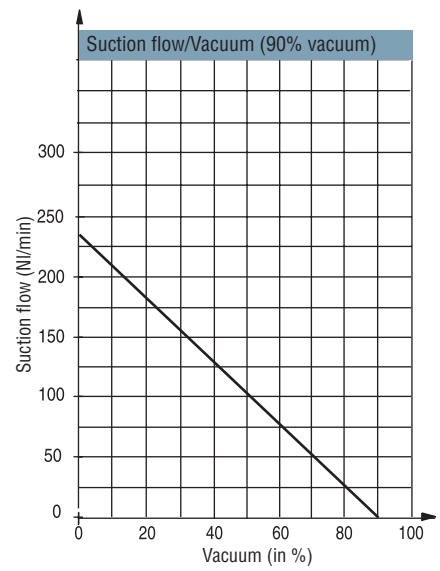
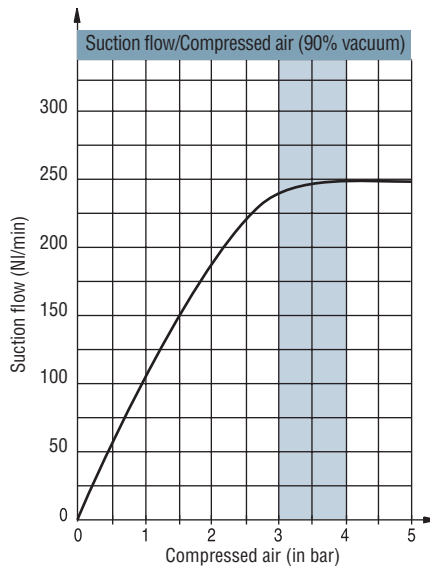
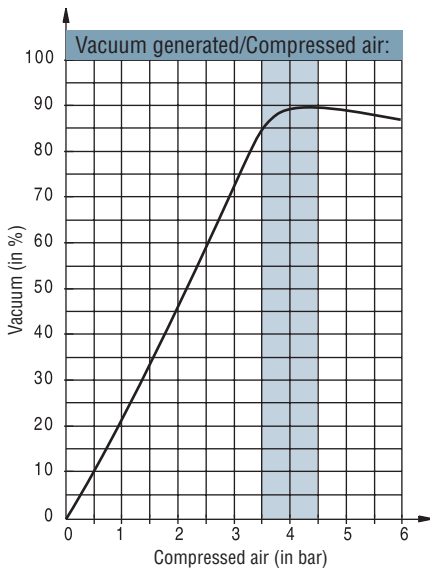

GVMAX SP 345V3 B2



GVMAXV3

Options

Manifold mounting

The GVMAXSP345V3 and V3R can also be manifold-mounted.

Up to 4 vacuum pumps can be installed on one base.

Manifold references (example with GVMAX SP 345 V3)

GVMAX SP 345V3 B1 (Base + 1 x GVMAX SP 345V3)

GVMAX SP 345V3 B2 (Base + 2 x GVMAX SP 345V3)

GVMAX SP 345V3 B3 (Base + 3 x GVMAX SP 345V3)

GVMAX SP 345V3 B4 (Base + 4 x GVMAX SP 345V3)

Protective housing for GVMAX SP345V3/V3R, ref. GVMAXV3

The protective housing for the GVMAX is transparent and removable. Coval recommends using a protective housing to protect the vacuum pump.

Self-regulating vacuum pumps with pneumatic vacuum control



Branch-specific applications



Description

The GVE series pneumatic vacuum pump is used to regulate the vacuum in a tank, a vacuum circuit, a suction pad and especially to significantly reduce consumption of compressed air. The advantages of this pump are its compatibility with a pneumatic control and its suitability for installation in high-risk environments (vacuum pump for explosive environments). Stopping the vacuum pump does not cause the circuit under vacuum to return to atmospheric pressure. Outside action is necessary (1/4 turn valve, solenoid valve, etc.).

This vacuum pump is ideal for holding air-tight objects and regulating the vacuum in a tank. Note: Tank volume must not exceed 10 liters. For larger volumes, please consult us.

Safety

The GVMAX P1 has a check valve function installed as standard which enables it to maintain the vacuum within the circuit if the pneumatic power is interrupted. This function guarantees maximum safety conditions for operators during handling.

Characteristics

model	Ø nozzle (mm)	max. vacuum (%)			air drawn in (NI/min)			L2 (mm)		weight (g)
		X	T	N	X	T	N	S	K ⁽¹⁾	
GVE P1	1.2	50	75	90	150	63	45	45	121	420
	1.5	50	75	90	180	95	70	45	121	420
	2	50	75	90	250	160	125	60	121	420
	2.5	50	75	90	360	240	200	60	121	420
	3	50	75	90	450	330	265	-	121	420

(1) delivered as standard on version X.

Materials

Similar to GEM (see page 9/2).

Evacuation time in seconds per liter

■ see table of evacuation time for the GVP series page 8/2.

Operating principle

When the selected vacuum level is reached, the compressed air supply stops.

This interruption does not have any effect on the current operation as the check valve maintains the vacuum and thus the grip.

The vacuum switch continually analyzes the vacuum requirements. As soon as the minimum threshold is reached, it actuates venturi opening. The chosen level of vacuum is immediately re-established.

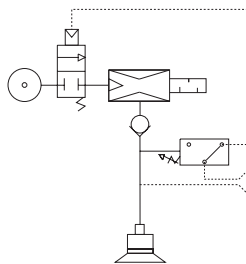

Specifications

Compressed air	Non-lubricated filtered air, 2 to 6 bar, optimum at 4 bar
Temperature	0 to 60 °C / 32 to 140°F
Material	POM - 2017A - Cu Zn
Vacuum switch	PSE 100 PKNO
Pressure at the vacuum switch	Equal to or greater than vacuum pumps supply pressure
Hysteresis	100mbar max.

For all orders, please specify: Model + Nozzle diameter + Characteristic + C.A. fitting + P1

1: Model GVE	2: Nozzle diameter 12 Ø 1.2mm 15 Ø 1.5mm 20 Ø 2mm 25 Ø 2.5mm 30 Ø 3mm	3: Characteristic X 50% vacuum T 75% vacuum N 90% vacuum	4: Silencer - Without silencer S ⁽¹⁾ Diffuser K Through-type	5: C.A. fitting 14 1/4 G BSPP 68 6x8 calibrated tube	P1
------------------------	---	--	---	---	-----------

(1) no silencer (S) for nozzle Ø 30.

E.g. GVE 15 TK 68 P1

(GVE vacuum pump, nozzle diameter 1.5mm, 75% vacuum with through type silencer and C.A. fitting, 6 x 8 calibrated tube)



- (1) Compressed air network
- (2) 1/2 Gas vacuum
- (3) 1/2 Gas Exhaust
- (4) Regulation threshold adjustment
- (5) PSE100PKNO vacuum switch
- (6) Hollow shaft for vacuum control vacuum switch pressurization
- (7) 1/4 Gas or fast 6x8

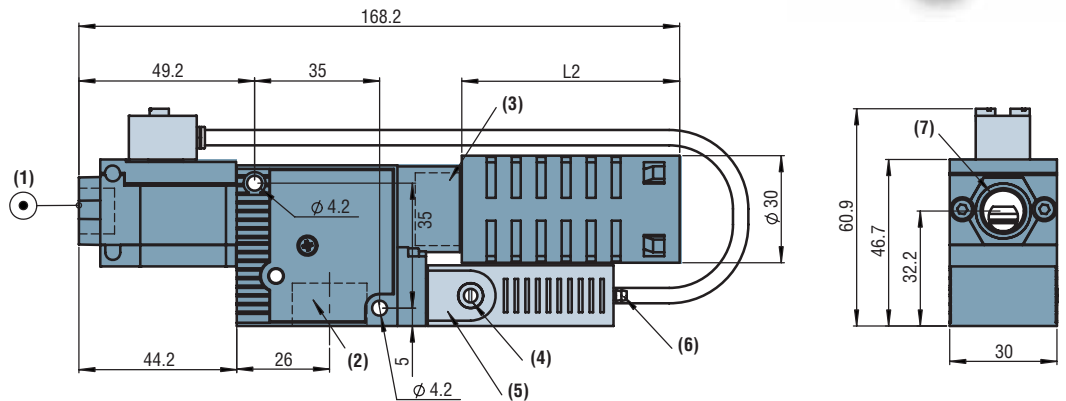

Curves

■ see page 8/19.

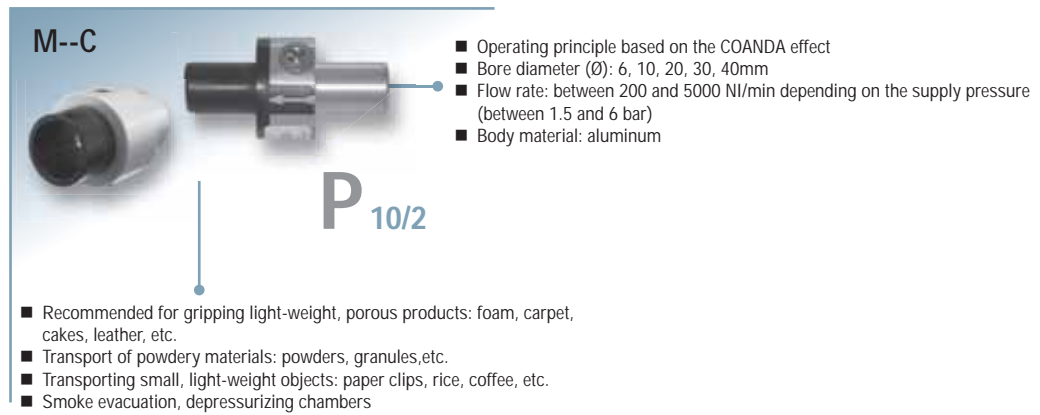



Description

By virtue of the COANDA effect (boundary effect), the motor flux draws in air at room temperature. This physical phenomenon greatly amplifies the flow which results in very high suction produced with low consumption.

- Gripping of very porous, light-weight products: foam, carpet, cakes, leather, etc.
- Transport of powdery materials: powders, granules, etc.
- Transporting small, light-weight objects: paper clips, rice, coffee, etc.
- Smoke evacuation, depressurizing chambers, etc.

operating requirement

Compressed air filtration at 5 microns for the M6C model and 20 microns for the other models.

- (1) Suction
- (2) Discharge
- (3) 1/4 Gas or fast 6x8
- (4) Control valve, on option.

Note: the valve is incompatible with the M40C model.

- A = - 77mm for an AP2 valve + DIN connection (connector supplied)
- 68mm for an AP2 valve + M12 connection (connector not supplied)
- 44mm for an AP2 + pneumatic connection for 2.7x4 tube.

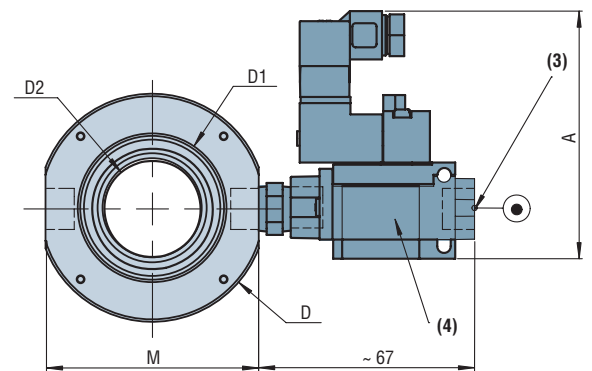
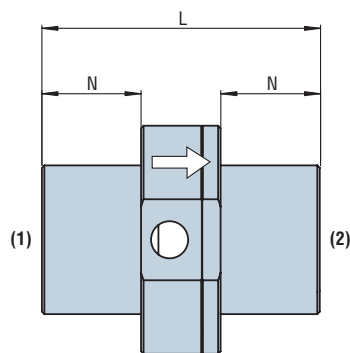

Additional information

- Based on specifications : special materials such as stainless steel or special models are available.
- The 5 products present the best amplification ratio (consumption/suction). COVAL can study smaller amplification ratios (higher consumption) but higher maximum vacuum for transporting heavy objects.
- Hardening treatments can be performed for transporting very abrasive products such as sand, etc.

Characteristics

models	L (mm)	N (mm)	M (mm)	C.A. (Gas)	D (mm)	D1 (mm)	D2 (mm)	Weight (g)
M 6 C	60	20	36	1/8	40	20	6	80
M 10 C	60	20	36	1/8	40	25	10	80
M 20 C	90	30	55	1/4	60	40	20	210
M 30 C	105	35	66	1/4	70	50	30	290
M 40 CV	114.5	40	86	3/8	92	60	40	470

Specifications

Compressed air	Dry non-lubricated 1.5 to 5 bar
Maximum pressure drop	see table page 10/3.
Flexible	Aluminum body
Temperature	-20 °C to 80 °C / -4 to 176°F

For all orders, please specify: M + bore Ø + C.A. control + C.A. fitting + valve controls

M	1: bore Ø		2: C.A. controls		3: C.A. fitting		4: Valve controls	
	6	M 6 C	-	Without control valve	14	1/4G BSPP	P1	Pneumatic
	10	M 10 C	AP2 ⁽³⁾	C.A. control valve	68	6 x 8 tube	E1	24 V DC DIN
	20	M 20 C					E1M	24 V DC M12
	30	M 30 C						
	40	M 40 CV						

E.g. M 30 C AP2 (Air amplifier with bore Ø M 30 C and C.A. control valve).

M--C series

Air amplifiers



Maximum vacuum / Supply pressure

Models	Supply pressure / Maximum vacuum in mm CE			
	2	3	4	5
M 6 C	900	1500	2000	2600
M 10 C	200	500	700	1000
M 20 C	207	310	400	510
M 30 C	90	130	220	280
M 40 C	140	200	284	360

Maximum overpressure/ Supply pressure

Models	Supply pressure / Maximum vacuum in mm CE			
	2	3	4	5
M 6 C	100	550	1300	2000
M 10 C	400	700	1500	2000
M 20 C	220	340	500	600
M 30 C	45	70	100	160
M 40 C	96	145	199	290

TVM series

Pipe for air amplifiers

Specifications

Diameter D	Ø 25 - Ø 40 - Ø 50 - Ø 60
Bend radius	10 x D
Maximum pressure drop	-250 mbar
Maximum pressure	1 bar
Temperature	-40 °C to 100 °C / -40 to 212°F
Anti-static	R < 108 Ohm

Description

Flexible polyurethane tube reinforced with a steel spiral covered in PVC. Highly resistant to abrasion, cutting fluids and UV light.

- Anti-static treatment in compliance with standard DIN 53486.
- Delivered with two Cerflex type clamps in standard format.

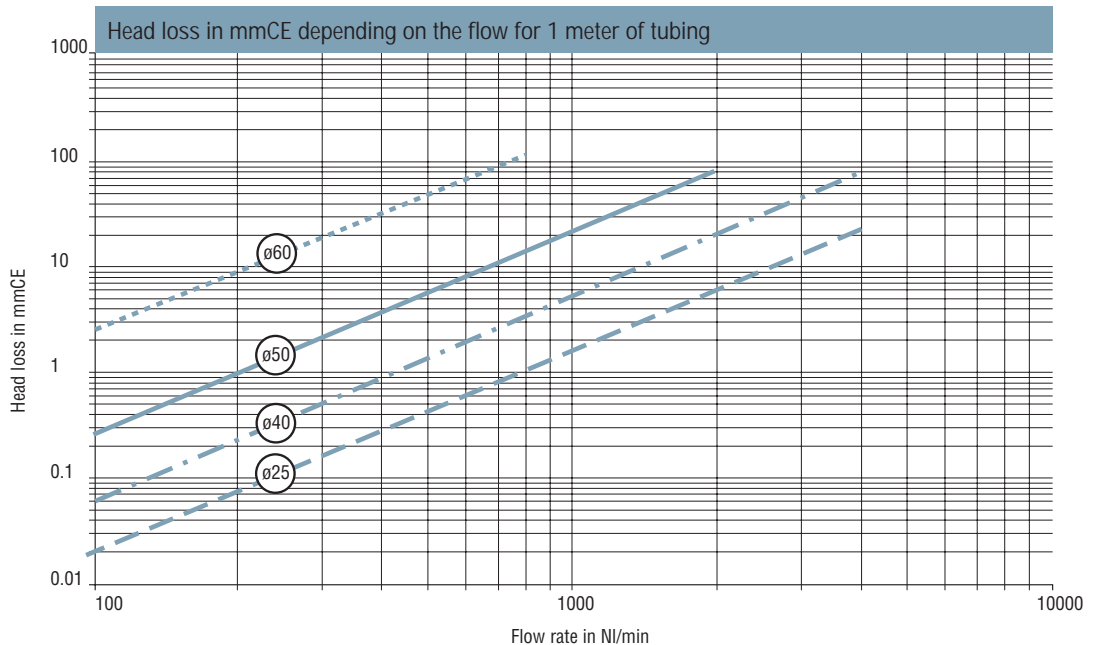

10

For all orders, please specify: Model + Diameter + Length

1: Model
TVM

2: Diameter
25 Ø 25mm
40 Ø 40mm
50 Ø 50mm
60 Ø 60mm

3: Length (m)
- In meters
10 A ring

E.g. TVM 50 10 (TVM model spiral pipe, ring diameter 50mm).



Blow-off, cleaning, waste suction

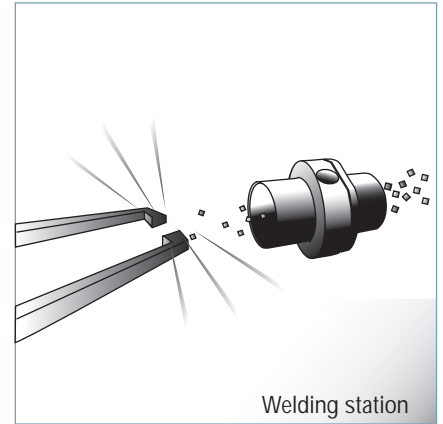
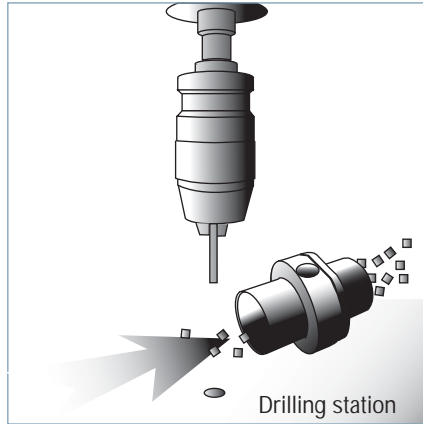

Sorting by weight

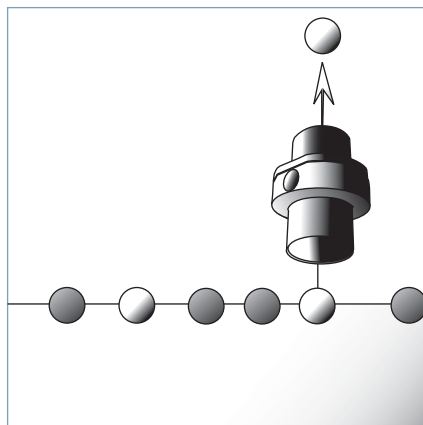

Transport of granules (rice, grains of wheat or coffee, etc.)

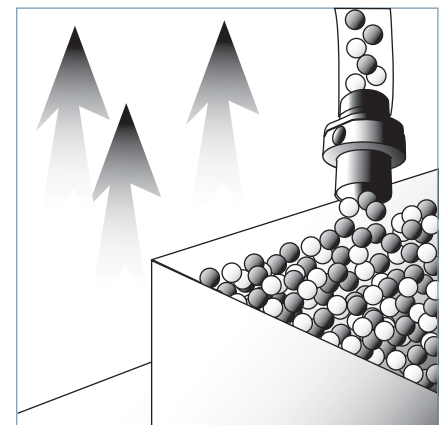

Degassing, smoke evacuation

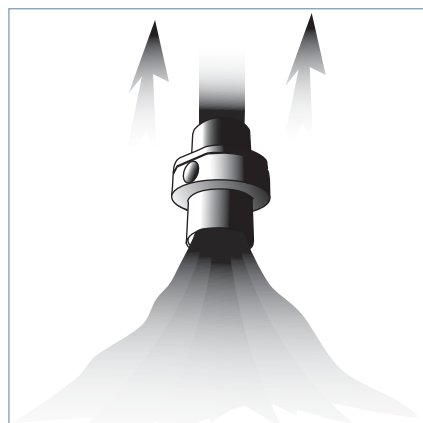

Gripping and / or unstacking very porous loads

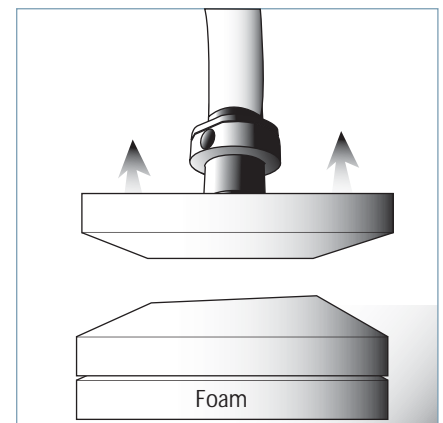

Possibility of mounting a PG30 vacuum switch, -100 to 100mb to detect objects.

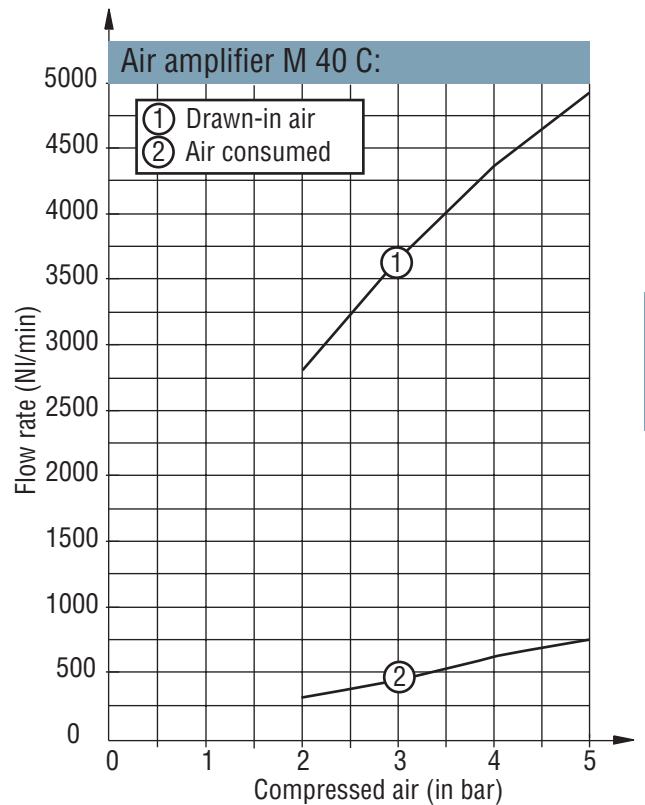
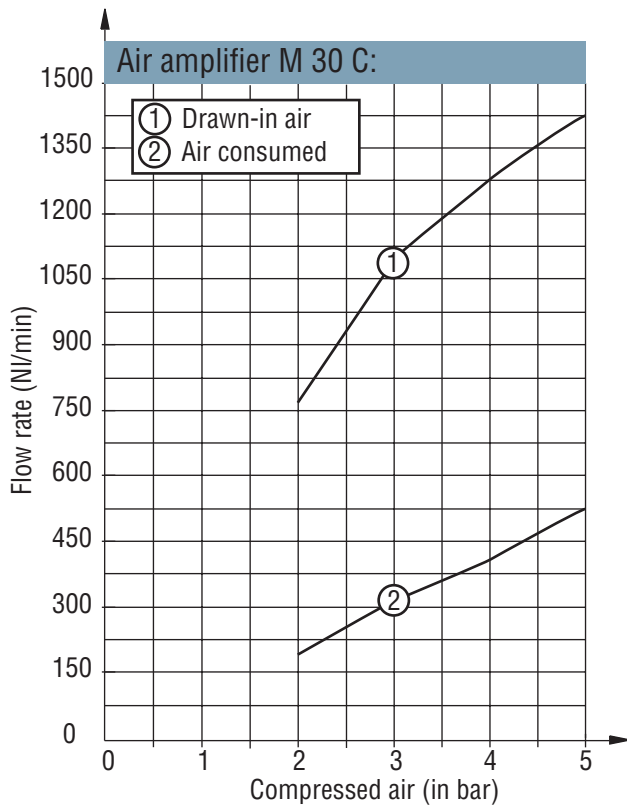
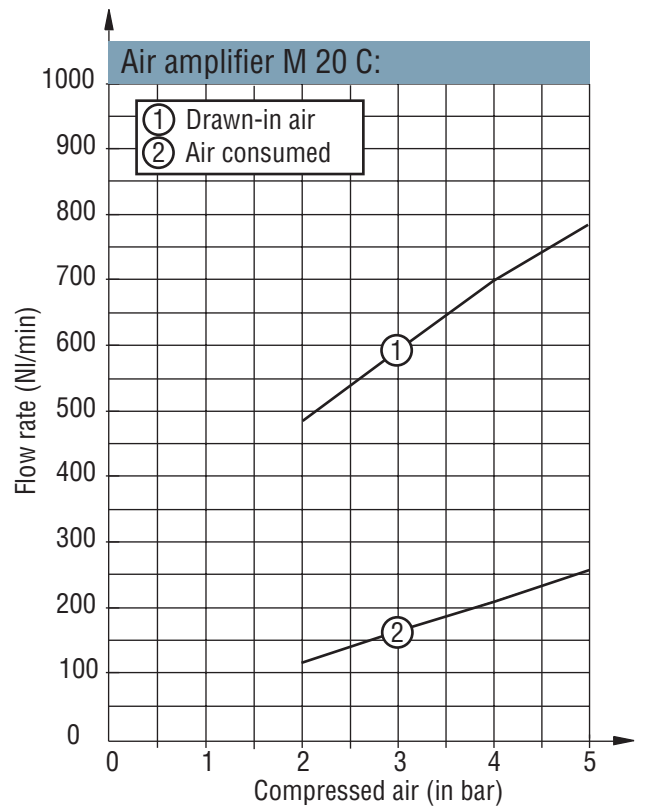
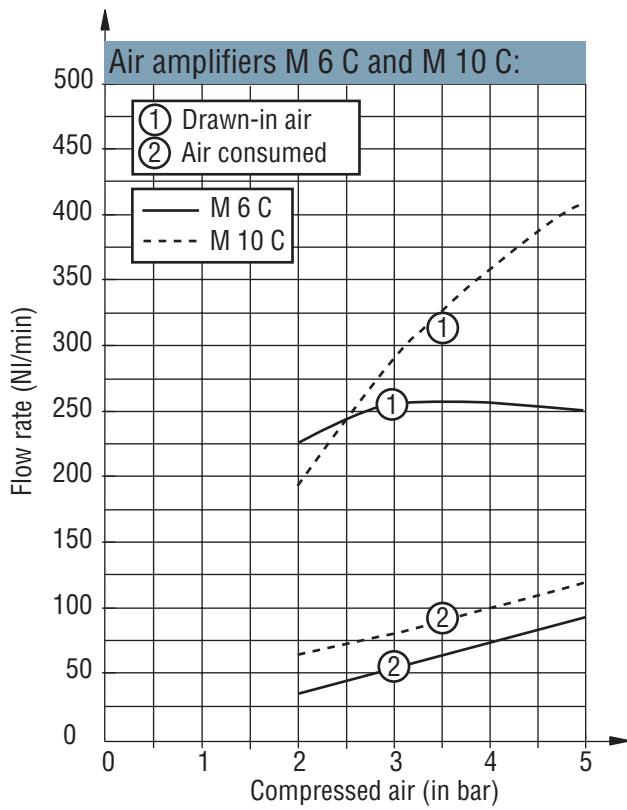

SIL GV



P_{11/2}

- Very good sound reduction
- Air outlet gently diffused
- Reduced size

- Diffuser type silencer
- Noise reduction of between 30 and 39 dBA
- Passage of air through a sound-proof material
- Available in 4 sizes
- 4 types of fitting, M5F, 1/8 G, 1/4 G, 1/2 G

SIL K--C



P_{11/2}

- Sound reduction mastered
- No clogging
- No head loss
- Ideal for dusty environments
- Possibility of collecting the exhaust

- Through type silencer
- Noise reduction of between 30 and 33 dBA
- Noise absorbed laterally by sound-proof textile
- Available in 5 sizes
- 3 types of fitting, 1/8 G, 1/4 G, 1/2 G

MS



P_{11/3}

- Allows direct blow-off on the VR type micro-ejectors or any other M5 fitting
- Reduces cycle times
- Avoids using a vacuum-proof distributor

- Blow-off device
- Direct connection on the micro- and mini-ejectors via an M5 fitting
- Pressure connection by push fitting for Ø 4x6 or 2.7x4 tube
- 100 Nl/min blow-off flow at 5 bar

FVI



P_{11/4}

- Ideal vacuum filter for high suction flow vacuum sources.
- Solution optimized to suit each operating environment thanks to three types of filtering material used in the filter cartridges
- A wide range adapted to your application
- Easy-to-replace cartridges in case of clogging

- A range of 8 different models of vacuum filters for optimum adaptation depending on the source of vacuum generation
- 3 filtration materials: paper, polyester and stainless steel
- 6 types of fitting, depending on the model: 3/8 G, 1/2 G, 3/4 G, 1"1/4 G, 1"1/4 G and 2" G.

FVUM, FVUG



P_{11/6}

- Transparent tank, visual checking on clogging possible
- Different models mean you can select a solution adapted to your application

- Vacuum filter
- A range of 4 models
- 2 sizes and 3 types of fittings: 1/4G, 3/8G and 1/2G
- Transparent tank

FVL12



P_{11/6}

- Easy to mount in-line on the vacuum network or directly on the vacuum pump

- In-line vacuum filters
- 400 micron stainless steel screen

FVG



P_{11/7}

- Ideal for mounting with micro and mini in-line ejectors
- Easy-to-replace cartridges in case of clogging

- Mini vacuum filters
- A range of 4 models

Pneumatic controls



P_{11/8}

- Ideal for use in explosive environments
- Ideal for applications controlled by pneumatic logic
- Manual control option

- Vacuum or blow-off control
- Supply pressure 2 to 6 bar
- Control pressure greater than or equal to the input pressure

SIL GV, SIL K -- C series

Diffuser type silencer, through type silencer

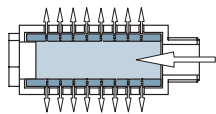

Diffuser type silencer

- Very good sound reduction
- Air outlet gently diffused.

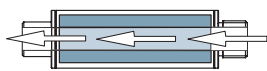

Through type silencer

- Sound reduction mastered.
- No clogging.
- No head loss.

From when it was founded, COVAL has always given particular attention to reducing the noise of vacuum pumps and improving their performance.

Often copied, never equalled, the acoustic performance of COVAL vacuum pumps stems from the inside shape of the venturi system and the innovative design of the hit-tech sound-proof materials used for the silencers.



SIL GV series diffuser-type silencer

Principle

Sound reduction by breaking up the air jet in a baffle inside the diffuser. Passage of air through a sound-proof material.

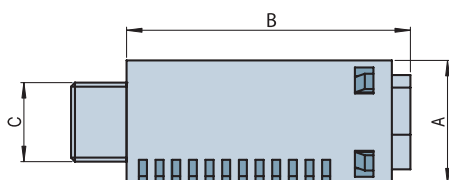

Characteristics

models	ØA (mm)	ØB (mm)	ØC (Gas)	Weight (g)	Medium-level sound reduction (dBA)
SIL GV 10 M5 F	18	36	M5F	5	30
SIL GV 10	18	36	1/8	5	30
SIL GV 15	20	46	1/4	10	35
SIL GV 20	30	62	1/2	29	39

Specifications

Material	POM (Polyoxymethylene)
Temperature	-10 to 50 °C / 14 to 122°F



SIL K -- C series through-type silencer

Principle

- Noise absorbed laterally by sound-proof textile.
- Free outlet without head loss or clogging.

Characteristics

models	ØA (mm)	ØB (mm)	ØC (Gas)	Weight (g)	Medium-level sound reduction (dBA)	Materials
SIL K 18 C	20	68	1/8	22	33	thread: aluminum tube: polycarbonate
SIL K 14 C	20	68	1/4	25	31	
SIL K 38 C	30	121	3/8	90	33	polycarbonate
SIL K 12 C	30	121	1/2	92	33	
SIL K 12 CS	30	54	1/2	61	28	

Specifications

Material	Black anodized aluminum or black polycarbonate (according to Ø) interior: Textile sound-proof material
Temperature	-10 to 50 °C / 14 to 122°F

Special: COVAL develops tailor-made through-type silencers according to specifications, male or female fitting, length, diameter, characteristics on request.



Pneumatic diagram

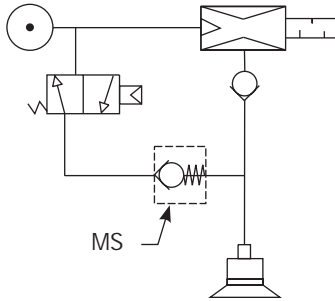

Description

Economical solution developed especially for the Coval micro-ejectors to satisfy applications requiring blow-off combined with small size and light weight. This device allows the user to connect the compressed air network directly onto the M5 fitting.

Advantages

- Allows blow-off on VR or any other M5 fitting
- Reduces cycle times
- Avoids using a vacuum-proof distributor.

Dimensions

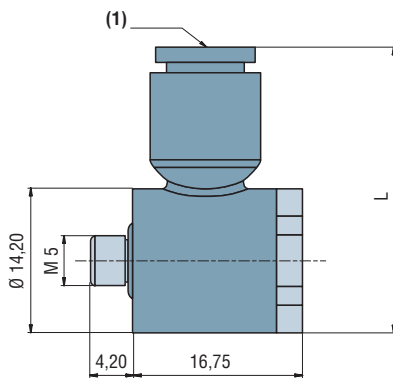

(1) Push fitting

Technical characteristics

- Pressure connection by push fitting for \varnothing 4x6 or 2.7x4 tube
- Connection to the vacuum network by M5 male threaded fitting
- Blow-off flow at 5 bar: 100 NI/min
- Materials: polyamide PA 6.6 + brass (CuZn) + nitrile (NBR)

model	push fitting (mm)	L (mm)
MS2M5	\varnothing 2.7x4	25,8
MS4M5	\varnothing 4x6	28,10

For all orders, please specify:

Model + Push fitting + M5

1: Model	2: Push fitting	M5
MS	2 \varnothing 2.7x4 pipe	
	4 \varnothing 4x6 pipe	

E.g. MS4M5

(Quick release device for \varnothing 4x6 mm pipe, M5 fitting)

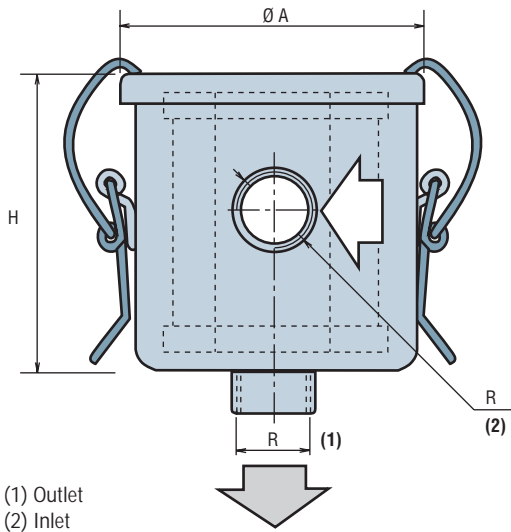

Description

The FVI range is compatible with pneumatic vacuum generators (venturi) or electric vacuum pumps (the FVI 2 model is suitable for a suction turbine). Each filter is fitted with an interchangeable cartridge treated to guarantee long life expectancy for the whole unit.

The filtering element consists of a 5 micron filter (made of paper for version C), which is sufficient to protect pumps and venturi under normal operating conditions.

Note: For filtration leaving large deposits (powder), mount the filter horizontally or upside down.

Important: These filters are designed for vacuum. They cannot withstand pressure greater than atmospheric pressure.

Filter cartridge available in 3 versions: paper, polyester and stainless steel.

Characteristics

models	A (mm)	H (mm)	R (Gas)	Flow rate (NI/min)	Weight (g)
FVI 38	79	76	3/8	400	270
FVI 12	101	86	1/2	600	600
FVI 34	101	86	3/4	600	600
FVI 114	135	96	1"1/4	1400/1200	1050
FVI 114 G	173	156	1"1/4	1400/1200	1850
FVI 2	201	258	2"	5000	3900

Specifications

Body material	Pressed steel sheet
Treatment	Black paint
Filtration	5 microns with a paper cartridge 3 microns with a polyester cartridge 60 microns with a stainless steel cartridge
Head loss	2 to 4% vacuum with a new filter 5 to 7% vacuum with average clogging

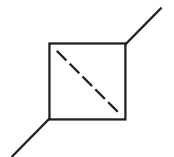

For all orders, please specify: Model + Fitting + Filtering material

1: Model
FVI

2: Fitting	
38	3/8 Gas
12	1/2 Gas
34	3/4 Gas
114	1"1/4
114G	1"1/4
2	2"

3: Filtering material	
C	Paper
P	Polyester
I	Stainless steel

E.g. FVI 38 P
(FVI series vacuum filter with 3/8 Gas fitting, polyester filtering).



Filter models

Models	Use
FVI 38	GVP 20 - GV 20
FVI 12	GVP 25 - 30 - PVR 6 (6 m ³ /h)
FVI 34	Vacuum pumps: 10/16 m ³ /h
FVI 114	Vacuum pumps: 20/25 m ³ /h
FVI 2	Turbine

Filtration

COVAL offers three filtration principles:

Model C: CE filtration element

- Paper cartridge with 5 micron filtration.
- No damp cleaning process possible.
- Incompatible to highly humid conditions

Model P: PE filtration element

- Polyester cartridge with 3 micron filtration.
- Damp cleaning possible.

Model I: IE filtration element

- Stainless steel cartridge, 60 micron filtration.
- For use in very damp environments (water, liquid)

Accessories

models	Replacement cartridge (*)	outside Ø (mm)	inside Ø (mm)	H2 (mm)
FVI 38	FVI 38*E	51	23	57
FVI 12	FVI 12*E	64	38	68
FVI 34	FVI 12*E	64	38	68
FVI 114	FVI 114*E	98	60	71
FVI 114 G	FVI 114G*E	125	64	125
FVI 2	FVI 2*E	149	88	221

(*) Specify the filter material: C (paper) ; P (polyester) ; I (stainless steel).

Replacement cartridge

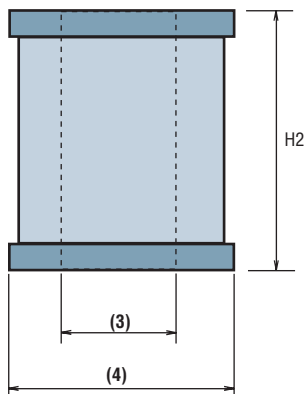

- (3) inside Ø
- (4) outside Ø

Other models

FVG 11-2-3-5-6 series vacuum filters, for micro-ejectors

- Polyester cartridge
- See page 11/7

FVU M 14-38 series vacuum filters for GVP 12 and 15 vacuum pumps

- FVU G 38-12 vacuum filters, in-line stainless steel cartridge for GVP 15 and 25 vacuum pumps and small electric PVR 6 vacuum pumps.
- See page 11/6

FVUM, FVUG series

In-line filters

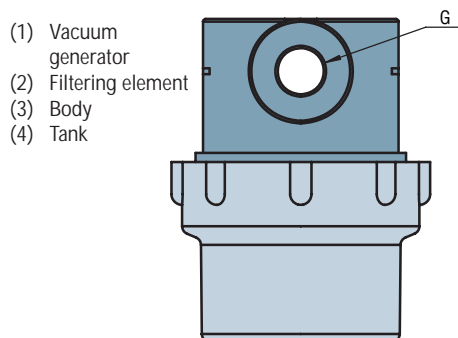
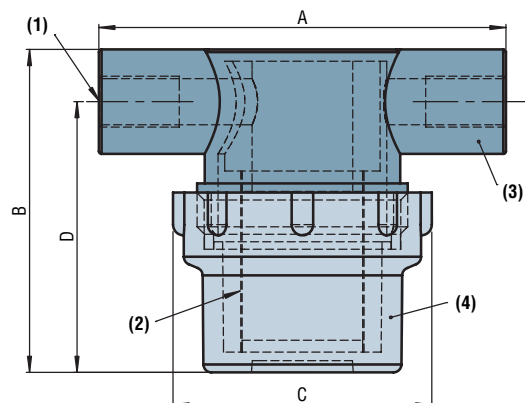

- (1) Vacuum generator
- (2) Filtering element
- (3) Body
- (4) Tank

Description

The advantage of this range of filters is that they are equipped with a transparent tank so that clogging is visible.

Characteristics

models	A (mm)	B (mm)	C (mm)	D (mm)	G (gas)	Flow rate (NI/min)
FVUM 14	76.2	61.5	48	49.8	1/4	150
FVUM 38	76.2	61.5	48	49.8	3/8	350
FVUG 38	90.9	136.7	73.6	119.4	1/4	350
FVUG 12	90.9	136.7	63	119.4	3/8	500

Operating range

■ - 1 to 10 bar

Specifications

Body material	Height: nylon 6.6 Tank: transparent polyamide
Filtration	Two options available: 40 micron stainless steel grille or Polyethylene 70 micron
Temperature	0 to 50 °C / 32 to 122°F

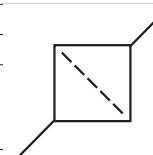

For all orders, please specify:

Model + Size + Fitting + Type of cartridge

1: Model	2: Size	3: Fitting	4: Cartridge
FVU	M Mini G Large	14 1/4G for M series 38 3/8G for M and G series 12 1/2G for G series	- Stainless steel P Polyethylene

E.g. FVU G 38

(FVU series in-line filter, Large, with 3/8 G fitting and stainless steel cartridge).

To order a replacement filtering element:

Filter model	Reference of the filtering element
FVUM14 and 38	FVUM12E (Stainless steel)
FVUG12 and 38	FVUG12E (Stainless steel)
FVUM14P and 38P	FVUM12PE (Polyethylene)
FVUG12 and 38P	FVUG12PE (Polyethylene)

FVL 12 series

In-line filter

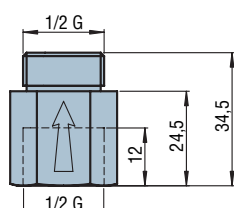
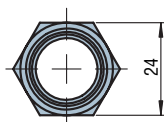

Specifications

Material	Body: Nickel-plated brass Grille: 400 micron stainless steel
Weight	50 g

Mounting on option

The FVL 12 series in-line filter can also be mounted as a GVO option on GVP series vacuum pumps. See page 8/18.

For all orders, please specify: FVL 12

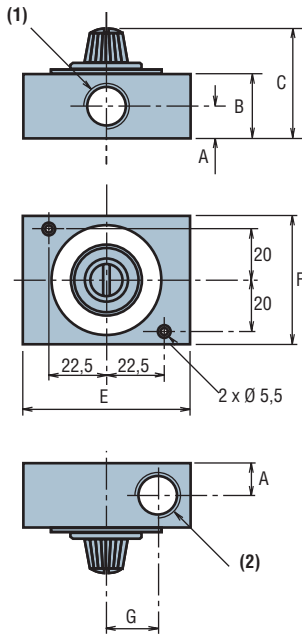

Description

FVG series vacuum filters are especially recommended for fine filtration. Their light weight allows easy on-board installation.

- (1) D1 (Inlet)
- (2) DE (Outlet)
- (3) Inlet

FVG 11 and FVG 2	VR 05
FVG 3	GV 10 - VR 07 - VR 09
FVG 5	GV 15 - GV 12 and 15
FVG 6	GVP 20 - GV 20

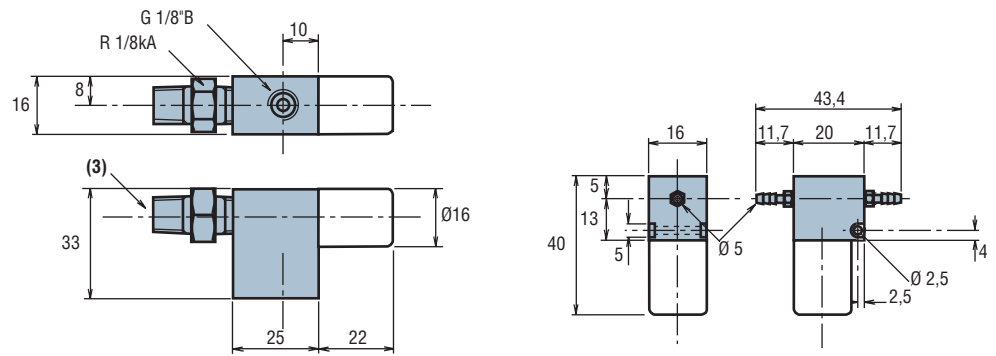

Characteristics

models	A (mm)	B (mm)	C (mm)	E (mm)	F (mm)	G (mm)	D2 (Gas)	D1 (Gas)
FVG 3	8	16	33	55.5	50.5	18	1/8	1/8
FVG 5	12.5	25	42	65	50	23	1/4	1/4
FVG 6	15	30	47	70	60	23	3/8	3/8

Specifications

Operating pressure	-1 to 5 bar
Temperature	0 to 60 °C / 32 to 140°F
Filtration (µ)	FVG 3-5-6: 40 ; FVG 11-2 : 120
Weight (g)	FVG 2/3/5/6/11: 45/90/150/235/18
Material	Anodized aluminum

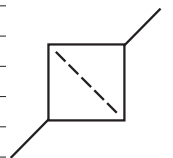

Accessories

Replacement cartridges: interchangeable filtration element.

Add E to the filter model reference to order the replacement cartridge.

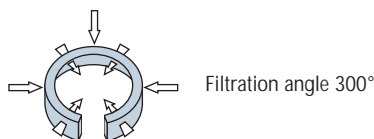

For all orders, please specify: Model + Type + Filters or Cartridges

1: Model	2: Type
FVG	11 FVG 11
	2 FVG 2
	3 FVG 3
	5 FVG 5
	6 FVG 6

3: Filters or Cartridge
- Filter
E Cartridge

E.g. FVG 11 E
(FVG 11 model mini vacuum filter, with cartridge).

Pneumatic controls for vacuum pumps

GVP, GVPS, GVPD, GVS, GVE



Pneumatic control

Description

The pneumatic control is useful for applications in an explosive environment. It is also useful for simultaneous control of several vacuum pumps by pneumatic logic.

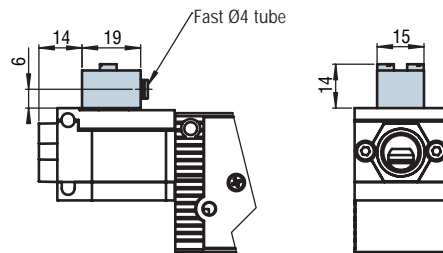

Specifications

Integrated fitting	For \varnothing 4mm calibrated tube
Supply pressure	2 to 6 bar
Pilot pressure	Equal to or greater than supply pressure
Manual control	On request
Interface seal under the control	2 x O-rings \varnothing 1.5 x 1 NBR not supplied with the control (ref: 09505001)

References: 09502001

PSA 100 C



- Electronic vacuum switch with digital display
- 2 configurable contact outputs
- NO or NC outlets
- Adjustable hysteresis
- IP 65

P 12/1

- The PSA100 C electronic vacuum switch is the most efficient vacuum measuring component in the COVAL range.
- It can be easily installed on all machines and robots, etc. thanks to its compact lightweight design.

PSP 100



- Electronic vacuum switch
- 1 configurable contact output
- Response time: < 5ms
- 3 vacuum fittings available
- 2 electric fittings available

P 12/2

- The compact PSP electronic vacuum switch is used to check the exact level of vacuum in the system.
- Adjustable contact output and hysteresis

PSE 100 E



- Electric vacuum switch
- Adjustment range -300mb to -850mb
- All voltages
- Cable or M12 connector outputs

P 12/3

- The PSE 100 E vacuum switch with electric output is used to check the vacuum level in the circuit.
- It is adapted to all electrical automated systems.
- The choice between the N.O. or N.C. function is made during wiring.

PSE 100 P



- Pneumatic vacuum switch
- 2 versions available (NO or NC)
- Adjustment range: -300mb to -850mb

P 12/4

- The PSE 100 E series vacuum switch with pneumatic output allows the vacuum level in the system to be checked by means of a patented system.
- This vacuum switch exists in two versions:
- N.O version, recommended for "air-saving" on the vacuum pump
- N.C. version to cover the "safety" function (object detected, etc.) and "SFC signal" function.

PSE 100 PK



- High-precision pneumatic vacuum switch.
- 2 versions available (NO or NC)
- Adjustment range:
 - NC: -250 to -830mb
 - NO: -350 to -880mb

P 12/5

- The vacuum switch with pneumatic output is used to check the vacuum level in the circuit. It is recommended for measuring slowly changing vacuum levels such as regulating or checking vacuum levels in networks over 1 liter.
- N.O version, recommended for "air-saving" on the vacuum pump.
- N.C. version to cover the "safety" function (object detected, etc.) and "SFC signal" function.

VAF 111



- Needle vacuum gauge
- 3 diameters available: 40, 50 and 63mm
- Zone for use printed red and green

P 12/6

- VAF 111 series vacuum gauges are recommended for viewing the level of vacuum on a network for maintenance, checking and adjustment purposes (Green zone of use: -0.65 to -1 bar)



Branch-specific applications

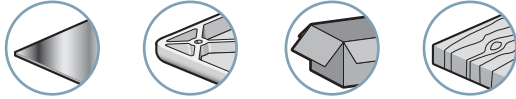

- 2 configurable contact outputs
- Adjustable hysteresis
- M8 F connector
- IP65
- LED display
- PNP

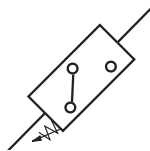

Description

The PSA100C series electronic vacuum switch is the most efficient COVAL vacuum measuring component. It can be easily installed on all machines and robots, etc. thanks to its compact lightweight design.

Moreover it has a digital vacuum level display with two independently-adjustable contact outputs. Every aspect has been designed to make it easy to use.

Advantages: front panel programming, simplified adjustment and threshold locking, display inversion, your choice of N.O or N.C. outlets (hysteresis can be independently adjusted for each outlet).

Characteristics

model	Measuring range (bar)	Permissible overpressure(bar)
PSA 100 C	0 / -1	4

Specifications

Compatible fluids	All non-corrosive, filtered, non-lubricated gases
Supply	18 - 30 V DC polarity inversion protection
Current consumed	< 100 mA
PNP transistor outlet	125mA with 24 V DC, programmable NO or NC
Output viewing	Led
Output 1	Red LED
Output 2	Green LED
Programming	Keyboard
Display	In % vacuum (2 digits, 7 red segments, size 8.5mm)
EMC	Industrial standard Class B
Enclosure material	PA 6.6 20% FV
Protection	IP 65
Electrical connection	M8 F connector
Pneumatic connection	1/8 Gas or M5 F
Shock resistance	10 G on XYZ
Display resolution	1%
Adjustment resolution	1%
Adjustment range	0 to 99% vacuum

Additional information

Electrical connection

- M8 connector

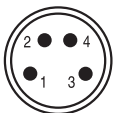

- 1 = + 24 V DC
- 2 = Output 2
- 3 = Common
- 4 = Output 1

Accessories

- Straight or elbow connector, see page 8/20.
- Connection on GVP series vacuum pumps: GVO PSA 100 C

Dimensions

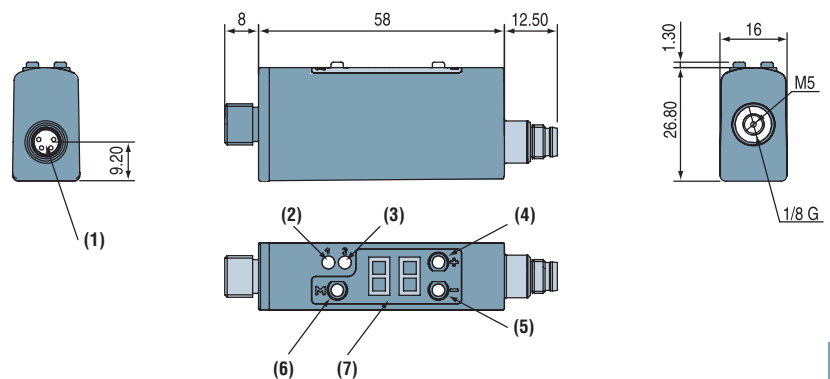

- (1) M8 4 pole connector
- (2) LED threshold 1
- (3) LED threshold 2
- (4) Up Key
- (5) Down Key
- (6) Menu selection MODE key
- (7) Vacuum level % digital display

For all orders, please specify: PSA 100 C

PSP 100 series

Electronic vacuum switch



Branch-specific applications

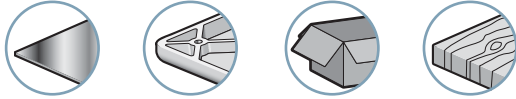

Characteristics

- 1 configurable contact output
- Adjustable hysteresis
- Measuring range: 0 / -1 bar
- Overpressure: +3 bar
- PNP

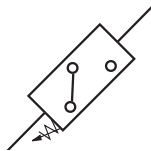

Additional information

- Factory set version on request.
- Mounting in GVO option in the GVP range.

Electrical connection

- PVC cable (length 2m)

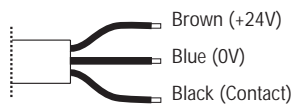

- M8 connector

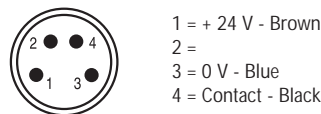

Accessories

- Straight or elbow connector, see page 8/20.
- Mounting on option GVO: ref. GVO PSP 100 L or GVO PSP 100 C.

Vacuum switch attachment - Clip ref.: PSE.F

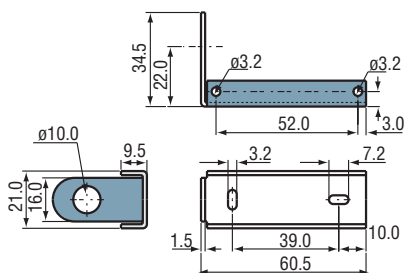

Description

PSP series electronic vacuum switches have integrated threshold and hysteresis adjustment as standard. 3 vacuum fittings (1/8 G Male, M5 female or M5 F Base) and 2 electrical connections (2 meters cable and M8 connector) make up the standard range.

Specifications

Models	PSP 100 L	PSP 100 LM5	PSP 100 C	PSP 100 CM5
Compatible fluids	All non-corrosive, filtered, non-lubricated gases			
Supply	Regulated 18-30 V DC, polarity inversion protection			
Current consumed	< 20mA			
Transistor outlet	N.O. 125mA with 24V DC			
Thermal drift	±3% of the measuring scale between 0 and 50°C / 32 to 122°F			
Output viewing	LED			
Response time	< 5ms			
Threshold adjustment	By 3/4 turn potentiometer			
Hysteresis adjustment	0 to 30% adjustment by 3/4 turn potentiometer			
EMC	Industrial standard class B			
Flexible	PA 66 and brass	PA 66 and Alu.	PA 66 and brass	PA 66 and Alu.
Temperature	when operating: 0 to 50 °C / 32 to 122°F in storage: -10 to 60 °C / 14 to 140°F			
Protection	IP 50			
Electrical connection	PVC cable (length 2m)		M8 connector (4 poles)	
Pneumatic connection	1/8 Gas or M5 F	M5F Base	1/8 Gas or M5 F	M5F Base
Weight	62g	67g	22g	27g
Adjustment range	0 to -1 bar			

Dimensions

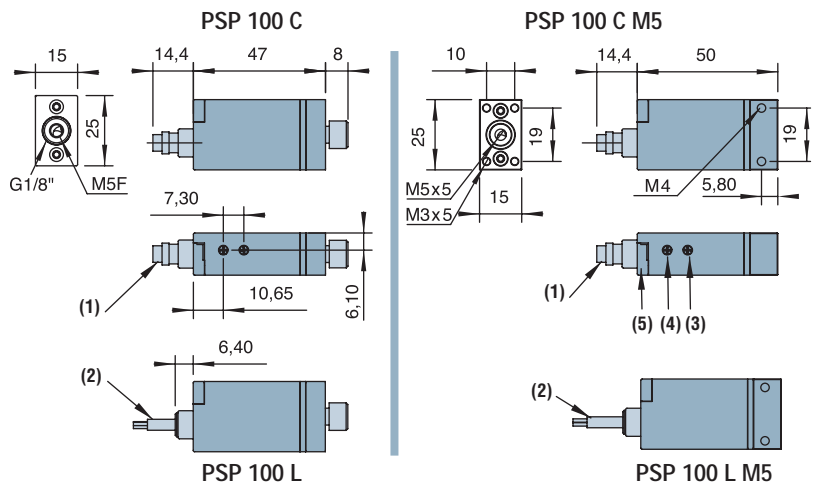

- (1) M8 4 pole connector version
- (2) PVC cable version (2 m)
- (3) Hysteresis adjustment
- (4) Threshold adjustment
- (5) Threshold display LED

For all orders, please specify:

Model + Electrical connection + Vacuum fitting

1: Model	2: Electrical connection	3: Vacuum fitting
PSP 100	L 2m cable	- 1/8G M or M5 F
	C M8 connector	M5 M5 F Base

E.g. PSP 100 L M5

(PSP 100 series electronic vacuum switch with 2 meter cable and M5 F base)



Branch-specific applications

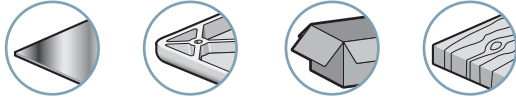

Description

VAF 111 series vacuum gauges are recommended for visually checking the vacuum level for maintenance, monitoring and adjustment purposes.

They are mounted as options on modular vacuum pumps GVP series, reference GVO VAF11140. See page 8/17.

Characteristics

Model	D ⁽¹⁾ (mm)	D1 (mm)	b1 (mm)	b2 (mm)	b3 (mm)	b4 (mm)	d (G male)
VAF 111 40	40	43	32.5	12	52	4	1/8
VAF 111 50	50	54	32.5	12	52	4	1/4
VAF 111 63	63	68	32.5	12	52	4	1/4

(1) Flush-mounting diameter.

Specifications

Damping	By silicone movement - Patented
Ring	Chrome
Measuring	Bourdon tube in CuSn
Precision	cl.2.5 (±2.5% of max. scale value)
Enclosure	Black ABS
Temperature	0 to 60°C / 32 to 140°F
Flush-mounting	Ring included in the delivery
Option	as per quantity, possibility of customized dial.

Dimensions

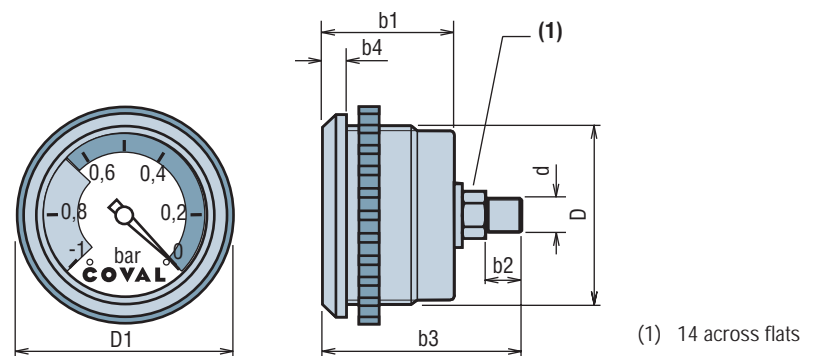

For all orders, please specify:
Model + Flush-mounting diameter

1: Model	2: Flush-mounting diameter
VAF 111	40 Ø 40mm
	50 Ø 50mm
	63 Ø 63mm

E.g. VAF 111 50
(VAF 111 series vacuum gauge with flush-mounting diameter 50mm)

NVS, NVR, NVA



P 13/2

- Vacuum feeders, 1 inlet, 4 to 8 outlets
- NVS: Screwed feeder fittings
- NVR: Push fitting feeder fittings
- NVA: Threaded aluminum feeder
- NVS and NVR series material: Polyamide 6.6 – 30% glass fibre, black, ULV094
- NVS and NVR series fittings material: Nickel-plated brass

- Facilitates optimum vacuum management by improved distribution
- Eliminates air pressure loss
- Simplifies connection
- Less time-consuming installation
- Compact and light-weight

RDV, RCOV, Y



P 13/3

- RDV, RCOV and RY series: Straight, adjustable elbow or Y fitting
- Diameter options: 5, 5/8, and 6/8, 7/10, 8/10, 10/12
- Gas fittings options: 1/2, 1/4, 1/8, 3/8,
- Material: Nickel-plated brass

- 100% vacuum-tight
- Integrated O-ring
- Improved circuit sealing
- Can be removed and reinstalled without requiring preparation of the tubing

RD, RC, RT, RU



P 13/4

- RD, RC, RT, RU series: Cylindrical straight male fittings, conical male elbow fitting; T fitting and Union
- Diameter options (Ø): 6/4, 8/6, 10/8, 12/10
- Gas fittings options: 1/2, 1/4, 1/8, 3/8,
- Material: Nickel-plated brass

- Vacuum-tight
- Improved circuit sealing
- Can be removed and reinstalled without requiring preparation of the tubing

RVM, RVF, RVT



- Barbed fittings guarantee a rigid connection between the source and the vacuum tube

TVR



- Rigid tubes allow a vacuum network to be installed with no pressure loss

COV



- Clamps used on TVR type pipes to guarantee network sealing

P 13/5

REV 38



P 13/6

- Vacuum regulator
- Adjustment precision: 0.13mbar
- Materials used in the VITON body and lacquered aluminum foundry
- Adjustment by threaded pin
- 3/8 G fitting attachment bracket

- Direct connection to a vacuum pump
- Very fine adjustment

AG



P 13/7

- Vacuum valve
- Connection to the vacuum network
- Electric control
- Voltage: 12 VDC, 24 VDC or VAC, 110 VAC, 220 VAC
- N.O or N.C for the vacuum or compressed air supplied servo

- Facilitates vacuum or compressed air network management
- N.O. or N.C. option allows adaptation to suit the application

PA



P 13/8

- Angular jaw clamps
- Adjustment of finger speed with compressed air regulator
- 3 models

- For use on all types of manipulators
- Recommended for injection press unloading robots for parts or sprue

AP2, AP3



P 13/9

- Electrically controlled valves
- Voltage 24V DC
- Electric version available in DIN or M12
- C.A. pressure: 2 to 7 bar
- Available in 2/2, 3/2, 2 x 2/2
- Operating frequency 2 Hz
- Maximum flow 750NL/min dry air

- Light weight and compact
- Low consumption
- A choice adapted to your application

NVS, NVR, NVA series

Vacuum feeders



Use

The NVS and NVR series vacuum feeders allow distribution of the vacuum in 4 to 8 channels by a simple unit. The 8/10 inlets and 4 or 8 6/8 outlets eliminate pressure loss.

Characteristics

Models	Screwed vacuum fittings		Push fittings		Threaded	
	NVS 4	NVS 8	NVR 4	NVR 8	NVA 4	
Material	Body	PA 6.6 – 30 % fiber glass, black, ULV094				Aluminum 2014 A
	fitting	Nickel-plated brass		PA		
For tube	calibrated polyamide or polyurethane (PUR)				4 x 1/4G and 1 x 3/8G	
Vacuum	■ ++	■ ++	■	■	■ ++	
Pressure (up to 10 bar max.)	-	-	■	■	■	

■ ++ Recommended for vacuum networks with regulation

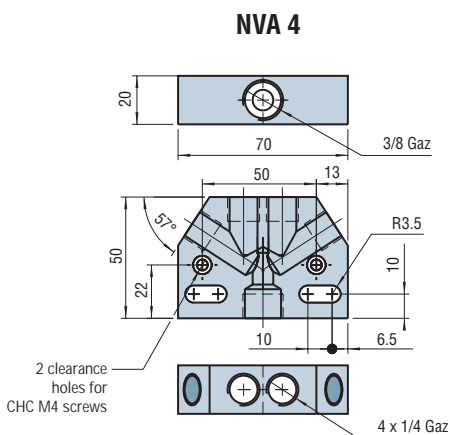
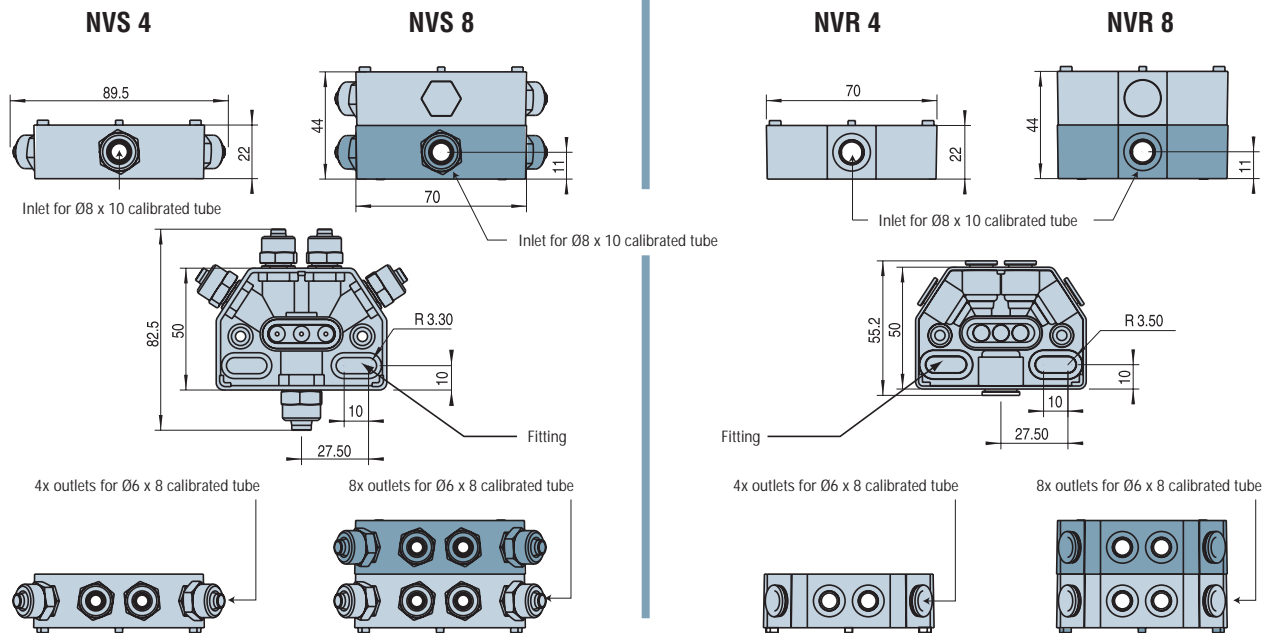

For all orders, please specify:

Model + Type + Number of outlets

1: Model

NV

2: Type

S screwed fittings

R push fittings

A threaded

3: Number of outlets

4 4 outlets - 1 inlet

8 8 outlets - 1 inlet

E.g. NV S 8

(NV type vacuum feeder, screwed fittings with 8 outlets and 1 inlet)

Note: for NVA series, one reference only: NVA 4 (aluminum feeder)

RDV, RCOV, Y series

Screwed vacuum fittings with O-ring

Characteristics

Range of special vacuum-tight fittings, fitted with O-ring (blue).

- 100% vacuum-tight and improved circuit sealing,
- Can be removed and reinstalled without requiring preparation of the tubing,
- Adjustable fittings for improved vacuum distribution,
- Material: nickel-plated brass.

RDV series straight fitting

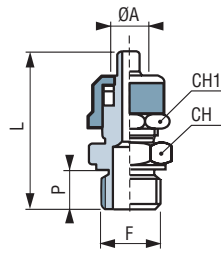

Ref.	ØA (mm)	F	CH (mm)	CH1 (mm)	P (mm)	L (mm)
RDV1868	6/8*	1/8G	14	14	6	26
RDV1468	6/8*	1/4G	17	14	8	29
RDV14810	8/10	1/4G	17	16	9	30.5
RDV3868	6/8*	3/8G	19	14	9	30.5
RDV38810	8/10	3/8G	19	16	9	32
RDV38812	8/12	3/8G	19	19	9	32.3
RDV12810	8/10	1/2G	24	16	10	33.5
RDV381012	10/12	3/8G	19	19	9	32.3
RDV12812	8/12	1/2G	24	19	10	34.5
RDV121012	10/12	1/2G	24	19	10	34

* 6/8 fittings are 5.5/8 compatible.

RCOV series elbowed fitting

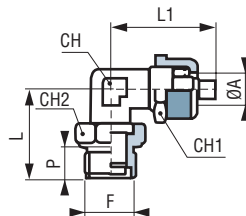

Ref.	ØA (mm)	F	CH (mm)	CH1 (mm)	CH2 (mm)	P (mm)	L (mm)	L1 (mm)
RCOV1868	6/8*	1/8G	10	14	14	7	24	22
RCOV1468	6/8*	1/4G	13	14	17	9	28.5	27.5
RCOV14810	8/10	1/4G	13	16	17	9	28.5	28
RCOV3868	6/8	3/8G	13	14	22	9	29	27.5
RCOV38810	8/10	3/8G	13	16	22	9	29	28
RCOV12810	8/10	1/2G	17	16	26	10	35	34
RCOV121012	10/12	1/2G	17	19	26	10	35	34

* 6/8 fittings are 5.5/8 compatible.

Y fitting, Y series



Ref.	ØE (mm)	ØS (mm)
Y68	6/8*	6/8*
Y810	8/10	8/10
Y81068	8/10	6/8
Y812	8/12	8/12
Y81268	8/12	6/8
Y1012	10/12	10/12
Y1012810	10/12	8/10

* 6/8 fittings are 5.5/8 compatible.

RD, RC, RT, RU series

Standard screwed vacuum fittings

Characteristics

Range of standard vacuum-tight fittings.

- Improved circuit sealing and a standard range,
- Can be removed and reinstalled without requiring preparation of the tubing,
- Material: nickel-plated brass.

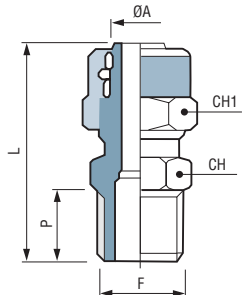

RD series cylindrical straight male fitting

Ref.	ØA (mm)	F	CH (mm)	CH1 (mm)	P (mm)	L (mm)
RD1846	6/4	1/8G	14	12	6.0	25.0
RD1446	6/4	1/4G	17	12	8.0	28.0
RD1868	8/6	1/8G	14	14	6.0	26.0
RD1468	8/6	1/4G	17	14	8.0	29.0
RD3868	8/6	3/8G	19	14	9.0	30.5
RD18810	10/8	1/8G	14	16	6.0	27.5
RD14810	10/8	1/4G	17	16	8.0	30.5
RD38810	10/8	3/8G	19	16	9.0	32.0
RD12810	10/8	1/2G	24	16	10.0	33.5
RD381012	12/10	3/8G	19	19	9.0	32.5
RD121012	12/10	1/2G	24	19	10.0	34.0

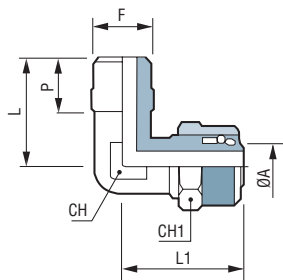

RC series conical male elbow fitting

Ref.	ØA (mm)	F	CH (mm)	CH1 (mm)	P (mm)	L (mm)	L1 (mm)
RC1846	6/4	1/8G	9	12	8.0	18.5	22.0
RC1446	6/4	1/4G	10	12	11.0	21.0	23.5
RC1868	8/6	1/8G	10	14	8.0	19.5	24.0
RC1468	8/6	1/4G	10	14	11.0	21.0	24.0
RC3846	6/4	3/8G	11	12	11.0	22.0	25.5
RC3868	8/6	3/8G	11	14	11.0	22.0	25.5
RC1268	8/6	1/2G	17	14	14.0	29.0	30.0
RC18810	10/8	1/8G	11	16	8.0	20.5	25.5
RC14810	10/8	1/4G	11	16	11.0	22.0	26.0
RC38810	10/8	3/8G	11	16	11.0	22.0	26.0
RC12810	10/8	1/2G	17	16	14.0	29.0	30.0
RC141012	12/10	1/4G	13	19	11.0	24.0	30.0
RC381012	12/10	3/8G	13	19	11.0	24.0	28.5
RC121012	12/10	1/2G	17	19	14.0	29.0	30.0

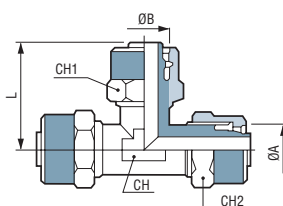

RT series T fitting

Ref.	ØA (mm)	ØB (mm)	CH (mm)	CH1 (mm)	CH2 (mm)	L (mm)
RT46	6/4	6/4	8	12	12	22.5
RT68	8/6	8/6	10	14	14	23.0
RT810	10/8	10/8	12	16	16	26.0
RT1012	12/10	12/10	12	19	19	29.0
RT6846	8/6	6/4	10	14	12	22.5
RT81046	10/8	6/4	12	16	12	25.5
RT81068	10/8	8/6	12	16	14	25.5

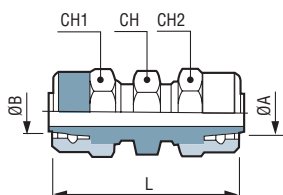

RU series union fitting

Ref.	ØA (mm)	ØB (mm)	CH (mm)	CH1 (mm)	CH2 (mm)	L (mm)
RU46	6/4	6/4	12	12	12	35.0
RU68	8/6	8/6	12	14	14	37.0
RU810	10/8	10/8	14	16	16	40.0
RU1012	12/10	12/10	17	19	19	38.0
RU4668	6/4	8/6	12	12	14	36.0
RU46810	6/4	10/8	14	12	16	37.5
RU68810	8/6	10/8	14	14	16	38.5

RVM, RVF, RVT series

Fittings

Characteristics

■ Material: brass.

Models	D	D1	D2	d*
RVM 1014	1/4	-	-	10
RVM 1038	3/8	-	-	10
RVM 1538	3/8	-	-	15
RVM 1512	1/2	-	-	15
RVM 2012	1/2	-	-	20
RVM 2034	3/4	-	-	20
RVF 1038	3/8	-	-	10
RVF 1512	1/2	-	-	15
RVF 2034	3/4	-	-	20
RVT 1012	-	1/2	3/8	10
RVT 1534	-	3/4	1/2	15

(*) Inside diameter of the suitable pipe

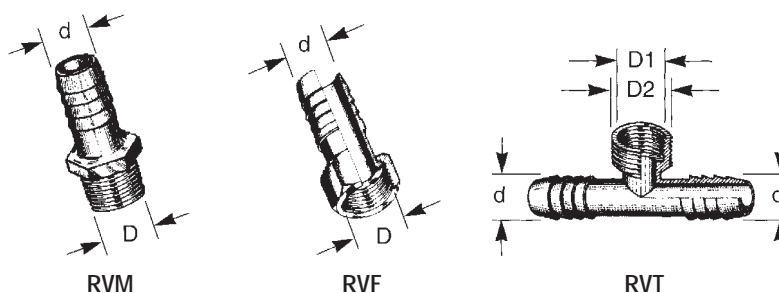

Description

Barbed fittings used to connect the vacuum source to the vacuum tube to guarantee a rigid connection.

TVR series

Vacuum tubes

Characteristics

Models	inside Ø (mm)	outside Ø (mm)	r* (mm)
TVR 10	10	16	18
TVR 15	15.5	22.5	30
TVR 20	19.5	27.5	37

*r: minimum bend fitting

TVR vacuum tubes hold a 90% vacuum with an ambient temperature of 30°C / 86°F.

Colour: Crystal



Description

Thanks to their rigid design and steel coil, they ensure that there is no pressure loss on the vacuum network.

COV series

Clamps

Characteristics

■ Material: stainless steel

Models	Tube ref.	L (mm)
COV 10	TVR 10	7
COV 15	TVR 15	7
COV 20	TVR 20	7

Other dimensions and shapes on request.



Description

Accessory to be used for attaching TVR type pipes to guarantee perfect sealing.



Description

When connected to an electric vacuum pump, the REV series vacuum regulators ensure there is a precise, stable vacuum. The user can obtain very fine adjustment thanks to the adjustment knob.

Characteristics

- Adjustment range: -13.3 to -100mbar
- Adjustment accuracy: ± 0.13 mbar
- Through flow: 16.2 Nm³/h

Specifications

Diaphragm	VITON
Material	Lacquered aluminum foundry
Adjustment	by threaded pin
Attachment bracket	Delivered as standard

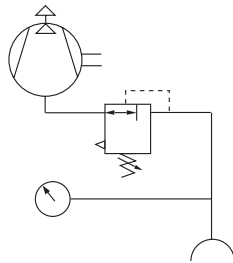

Dimensions

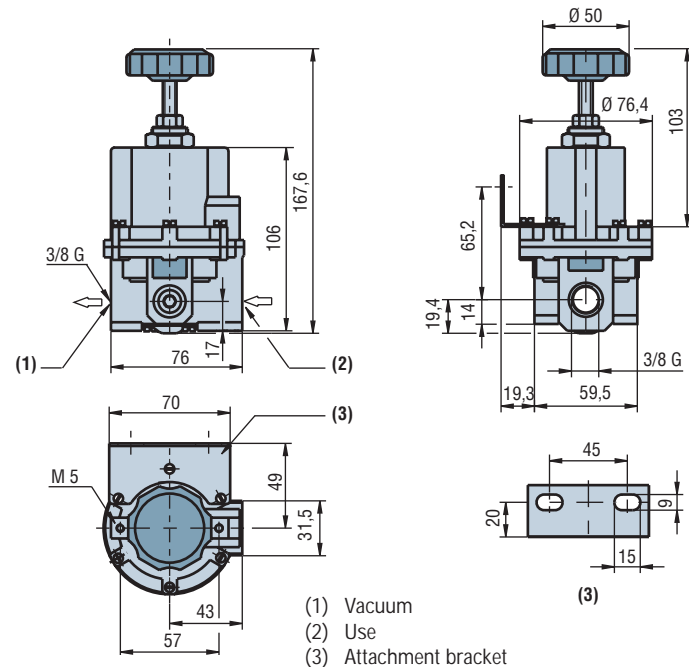

For all orders, please specify: REV 38



Description

NC vacuum supplied servo

3: Exhaust
2: Use
1: Pump

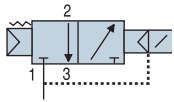

NC CA supplied servo

3: Exhaust
2: Use
1: Pump

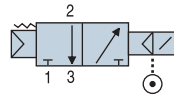

NO vacuum supplied servo

3: Exhaust
2: Use
1: Pump

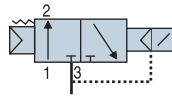

NO CA supplied servo

3: Exhaust
2: Use
1: Pump

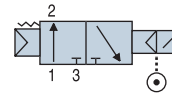

Characteristics and dimensions

Diagram 1

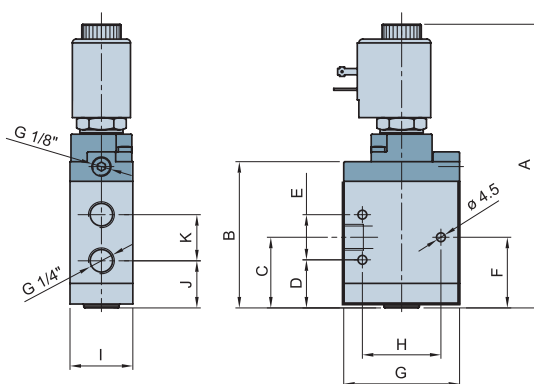
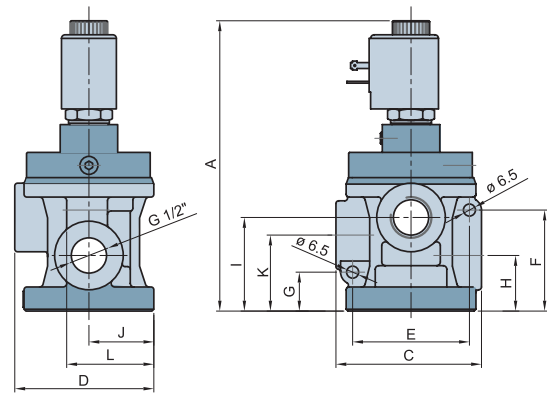

Diagram 2



Ref. NO AC servo	Ref. NC AC servo	Ref. NO Vacuum servo	Ref. NC Vacuum servo	Fitting Gas	A	B	C	D	E	F	G	H	I	J	K	L	M	Ø	diagrams
AG 3002	AG 3001			1/8"	100	52.7		9.2		19.7	35	28	25	11	17.5				1
AG 3010	AG 3009	AG 3211	AG 3210	1/4"	144.5	74.5	36	24.5	23	36	59	40	32	24	23.5		4.5	1	1
AG 3012	AG 3011	AG 3215	AG 3214	3/8"	144.5	74.5	36	24.5	23	36	59	40	32	24	23.5		4.5	1	1
AG 3021	AG 3020	AG 3223	AG 3222	1/2"	156.6	100.6	78.5	75	63	54.5	21	30	50.5	35	41	47		6.5	2
AG 3041	AG 3040	AG 3233	AG 3232	3/4"	156.6	100.6	78.5	75	63	54.5	21	30	50.5	35	41	47		6.5	2
AG 3051	AG 3050	AG 3243	AG 3242	1"	172.7	116.7	101	94	76	62.5	25.5	38	64	45	51	55		8.4	2
AG 3063	AG 3062	AG 3257	AG 3256	1 1/2"	188	172	158	138	113	113	34	50	96	51	68	84	62	11	2

Specifications

Fluid	Non-lubricated 50 micron filtered air. If lubrication is used it must be uninterrupted	
Maximum vacuum	97 %	
Operating temperature	-20°C +40°C / -4 to 104°F	
Fluid temperature	max +40°C / 104°F	
Dynamic seal	polyurethane	
Static seal	NBR	
Coil power	11 VA	10 VA
Voltage	12V DC / 24V DC	24V AC / 110V AC / 220V AC
Minimum vacuum for vacuum supplied servo	20 %	

For all orders, please specify:
Model + Voltage

1: Reference of model

see Characteristics

2: Voltage

see Specifications

E.g. AG 3215 110 VAC
(AG series 3-channel vacuum valve, NO vacuum supplied servo, voltage 110 VAC)

Flow rate

Connection	1/8"	1/4"	3/8"	1/2"	3/4"	1"	1 1/2"
Nominal diameter [mm]	5,5	8	10	15	19	25	39
Flow [m3/h]	1,5	4	10	20	35	90	180
Response time (activation) ⁽¹⁾	15	18	18	20	20	20	60
Response time (deactivation) ⁽¹⁾	25	28	28	40	40	45	40
Minimum control pressure (bar) for AC servo	1.5	2.5	2.5	3	3	3	4

(1) with monostable electrical control



Description

The PA series angular jaw clamps are used in robotics and the plastics industry and more generally on all types of manipulators. They are particularly recommended for use on injection press unloading robots for parts.

Choose a clamp with a theoretical force at least equal to twice the effective force required.

The clamping forces in the table above are theoretical forces and are given for a pressure of 6 bar. Gripping force is inversely proportional to the distance between the gripping point and the fulcrum.

For example, for a PA 20 clamp with the gripping point 25mm from the fulcrum, the clamping force will be:

$$F = 10.1 \text{ (table below)} \times 15/25 = 6.06\text{Kg.}$$

The weight of the objects to be handled is added to that of the clamp and must not exceed 1/20th of the force exerted on the gripping point.

The opening and closing speed of the fingers can be adjusted with the compressed air regulator.

- DE: double action clamp using compressed air.
- SEF: closure by compressed air, opening by return spring (closure action only).
- SEO: opening by compressed air, closure by return spring (opening action only).

Specifications

Compressed air	Filtered, lubricated or non-lubricated
Maximum pressure	10 bar
Material	Anodized aluminum
Seal	Nitrile (NBR)
Heat treatment	On pins and fingers
Operating temperature	-10° to 70 °C / 14 to 158°F

Characteristics

Models	Clamping force (kg)	Min. pressure (bar)	Weight (g)	Magnetic sensor option
PA 16 SEF	4	2,5	120	
PA 16 SEO	5,2	2,5	120	
PA 16 DE ⁽¹⁾	5.5 to 6.5	1,5	120	
PA 20 SEF	7,5	2	190	yes
PA 20 SEO	8,5	2	190	yes
PA 20 DE ⁽¹⁾	10.1 to 12.2	1,2	190	yes
PA 32 SEF	16,5	1,8	490	yes
PA 32 SEO	19,5	1,8	490	yes
PA 32 DE ⁽¹⁾	22 to 24	1	490	yes
PA 50 DE ⁽¹⁾	52 to 60	0,8	1660	yes

(1) The clamping force above is given in bar at a distance of 15mm from the fulcrum for models PA 16 - 20 - 32 and 30mm from the fulcrum for models PA 50.

For all orders, please specify:

Model + Action + Magnetic sensor

1: Model	2: Actions	3: Magnetic sensors
PA 16 to PA 50	SEF Closure action only	- Without
	SEO Opening action only	M For PA 20 - 32 - 50
	DE Double action	

E.g. PA 20 SEO M
(PA 20 model clamp jaws opening action only and magnetic sensor)

AP2 and AP3 series

Solenoid valve modules



M12 single valve



M12 double valve

Description

The 2/2 and 3/2 solenoid modules in series AP2 and AP3 offer 2 possible electrical connections: DIN and M12.

They are designed for flows of 750NI/min. Their compact, light-weight design means they can be placed close to the components they are controlling.

Specifications

Functions	AP2 = 2/2, AP3 = 3/2 and AP4 2 x 2/2
Operating pressure	2 to 7 bar
Maximum flow	750NI/min dry air
Number of operations	15 million
Weight	80g
Operating frequency	3Hz
Precautions	The valve does not transmit any mechanical force
Anti-parasite devices	Available for electric controls
Compressed air fitting	1/4 Gas or 6x8 push fitting

Characteristics

Voltage	Power	Function	Code
24V DC	1W	NC	E1

Dimensions

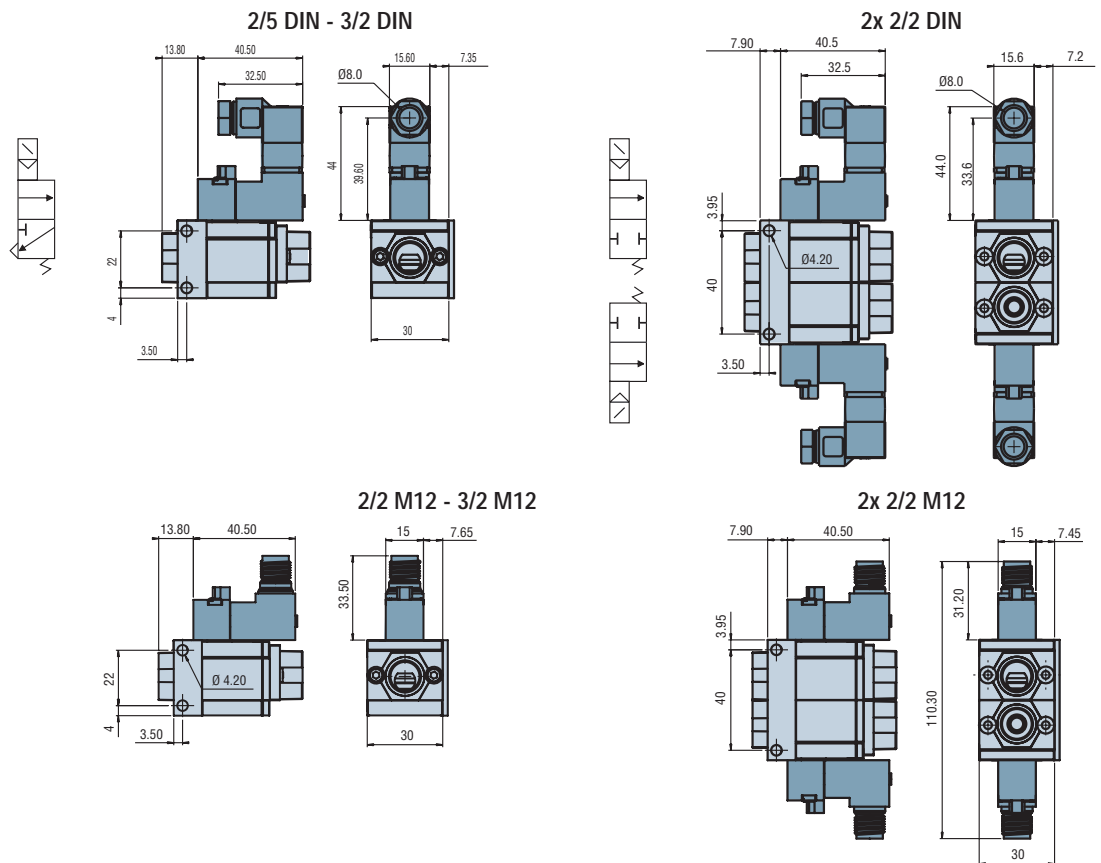

For all orders, please specify: Model + Number of channels + Fitting + Control

1: Model
AP

2: Number of channels
2 2/2 valve
3 3/2 valve
4 2 x 2/2 valve

3: Fitting
68 6 x 8 tube
14 1/4 Gas

4: control
E1 24V DC 1W - DIN
E1M 24V DC 1W - M12

E.g. AP 2 68 E1 (AP series solenoid valve module, 2/2 valve with 6x8 tube fitting and 24V DC - DIN electrical control)

Alphabetical index

A			
AG			
Vacuum valves, 3 channels	13/7		
AP2, AP3			
Solenoid valve modules	13/9		
Assembly diagrams			
VP - VSA - VS Ø 26... 63 mm	2/16		
VP - VSA - VS Ø 5... 25 mm	2/15		
VP - VSA - VS Ø 75... 95 mm	2/17		
VPG 1... 10 - VSAG 10... 15 - VSG 5 and 7	2/18		
VPG 15 and 20 - VSAJ 15 and 20	2/19		
VPG 25... 50 - VSAG 20B... 50 - VSAJ 30	2/20		
VPG 60... 200 - VSAG 75 and 150	2/21		
B			
BM			
Foam strips	5/14		
C			
CBC			
High-performance suction pads with 1.5 bellows	2/11		
CC			
Connectors for vacuum switches	8/20		
CD			
Connectors for vacuum switches	8/20		
CFC			
High-performance flat suction pads	2/11		
CIL			
In-line ejectors	7/2		
COBC			
High-performance oblong suction pads with 1.5 bellows	2/11		
COFC			
High-performance flat oblong suction pads	2/11		
COV			
Clamps	13/5		
CSP			
Piloted safety valves	5/13		
Curves			
Modular vacuum pumps	8/19		
customer-mounted			
Modular vacuum pump options	8/16		
F			
factory-mounted			
Modular vacuum pump options	8/18		
FVG			
Mini vacuum filters	11/7		
FVI			
Vacuum filter	11/4		
FVL 12			
In-line filter	11/6		
FVUG			
In-line filter	11/6		
FVUM			
In-line filter	11/6		
G			
GEM			
Integrated energy-saving vacuum pumps	9/2		
GEMP			
Simple energy-saving vacuum pumps	9/5		
General points			
Air-saving vacuum pumps	9/7		
GV			
Standard ejectors	7/14		
GVA			
In-line ejectors	7/4		
Options	7/6		
GVC			
Automatic blow-off capacity vacuum pump	8/4		
GVCS			
Vacuum pumps with automatic blow-off and electric vacuum control	8/6		
GVE			
Self-regulating vacuum pumps with electric vacuum control	9/16		
GVMAX			
Self-regulating vacuum pumps (electric vacuum and blow-off control)	9/10		
Self-regulating vacuum pumps (pneumatic vacuum and blow-off control)	9/11		
GVMAX V2			
Special self-regulating vacuum pumps (electric vacuum control and blow-off)	9/12, 9/14		
GVMAX V3			
Special self-regulating vacuum pumps (electric vacuum and blow-off control)	9/14		
GVO			
Modular vacuum pump options	8/16		
GVP			
Modular vacuum pumps	8/2		
GVPD			
Vacuum pumps with blow-off and electric vacuum control	8/10		
GVPS			
Vacuum pumps with electric vacuum control	8/8		
GVR 09 S, 10, 12, 14			
Micro ejectors	7/12		
GVS			
Safety vacuum pumps with electric vacuum and blow-off control	8/12		
Safety vacuum pumps with pneumatic vacuum and blow-off control	8/14		
I			
IF			
Female fittings	2/23		

Alphabetical index

IM		
Male fittings	2/22	
IMU		
Axial ball-joints	5/12	
IMUKGL		
Axial ball-joints	5/12	
IR		
Female fittings	2/23	
L		
L		
Extensions	5/6	
M		
M--C		
Air amplifiers	10/2	
Miscellaneous gripping	5/7	
MS		
Quick release device	11/3	
MVS		
Suction pads for opening bags	3/2	
N		
NVA		
Vacuum feeders	13/2	
NVR		
Vacuum feeders	13/2	
NVS		
Vacuum feeders	13/2	
P		
PA		
Angular jaw clamps	13/8	
PBA		
Automatic shut-off valves	5/10	
PBE		
Shut-off valves for air-tight products	5/11	
PBP		
Shut-off valves for porous products	5/11	
PMG2		
Mechanical feelers	5/9	
Pneumatic controls	11/8	
PSA 100 C		
Electronic vacuum switch with display	12/1	
PSE 100 E		
Electric vacuum switch	12/3	
PSE 100 P		
Pneumatic vacuum switch	12/4	
PSE 100 PK		
Pneumatic vacuum switch	12/5	
PSP 100		
Electronic vacuum switch	12/2	
R		
RC		
Standard screwed vacuum fittings	13/4	
RCS		
Systems with 4 compensated springs	5/4	
RCOV		
Screwed vacuum fittings with O-ring	13/3	
RD		
Standard screwed vacuum fittings	13/4	
RDV		
Screwed vacuum fittings with O-ring	13/3	
REV 38		
Vacuum regulator	13/6	
RT		
Standard screwed vacuum fittings	13/4	
RU		
Standard screwed vacuum fittings	13/4	
RVF		
Fittings	13/5	
RVM		
Fittings	13/5	
RVT		
Fittings	13/5	
S		
SIL GV		
Diffuser-type silencer	11/2	
SIL K--C		
Through-type silencers	11/2	
SPL		
Heavy load suction pads	3/15	
Steel (5020,5028,... 6020, 6028...)		
Round or rectangular steel suction pads with bonded seal	3/16	
Suction pad nozzle fittings		
Groups 1 and 2	5/8	
T		
TS		
Spring systems	5/2, 5/3, 5/4	
TSO / TSOP		
Anti-rotation spring systems	5/5	
TVM		
Pipe for air amplifiers	10/3	
TVR		
Vacuum tubes	13/5	
V		
VA		
Steel suction pads with removable seal	3/17	
VAF 111		
Vacuum gauge	12/6	

Alphabetical index

VCD		
CD suction pads	3/13	
VP		
Flat suction pads	2/2	
VPA		
Paper suction pads	3/8	
VPAG		
Rounded suction pads	3/9	
VPCD		
CD suction pads	3/13	
VPG		
Extra-flat suction pads	2/4	
VPO		
Oblong suction pads	2/10	
VPR		
Suction pads for mailing applications	3/9	
VPS		
VPS suction pads	3/12	
VPU		
Flat suction pads	4/2	
VPV		
Anti-abrasion suction pads	3/10	
VPYR		
Radial ball-joint suction pads	3/14	
VR 05, 07, 09		
Heavy duty in-line jectors	7/8	
VR 10, 12, 14		
Heavy duty in-line jectors	7/10	
VS		
Suction pads with 2.5 bellows	2/8	
VSA		
Suction pads with 1.5 bellows	2/6	
VSAB		
Suction pads with 1.5 bellows	4/4	
VSAG		
Suction pads with 1.5 bellows	4/6	
VSAJ		
Suction pads with 1.5 bellows	4/8	
VSAOV		
Anti-abrasion suction pads	3/10	
VSAV		
Anti-abrasion suction pads	3/10	
VSB		
Long stroke suction pads	3/5	
VSBM		
Foam rings	2/14	
VSBO		
Bottle suction pads	3/6	
VSD		
Long stroke suction pads	3/5	
Suction pads for bakery applications	3/4	
VSE		
Suction pads for bakery applications	3/4	
VSG		
Suction pads with 2.5 bellows	4/9	
VSO		
Suction pads for egg-handling	3/3	
VSP		
Suction pads for bakery applications	3/4	
VSV		
Anti-abrasion suction pads	3/10	
Y		
Y		
Screwed vacuum fittings with O-ring	13/3	
YS		
Spring systems	5/2, 5/3	

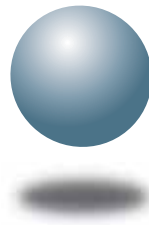

COVAL
vacuum managers

► COVAL - SYSTEMS

COVAL is also a specialist in the conception and manufacturing of a wide range of vacuum lifting systems. Coval vacuum systems are suitable for all types of applications. The equipment complies with all the stringent safety regulations for vacuum lifting.

For the last 15 years COVAL SYSTEMS UNIT proposes a complete range of suction pad vacuum lifters, tube lifters and now the vacuum grippers.

In addition to our consulting support, our product range offered in the general catalog, provides all the solutions to suit your applications.

VACUUM GRIPPERS

CVG Compatible to all types of applications, CVG grippers are ideal for miscellaneous gripping of objects differing in shapes & sizes. CVG grippers are based on ball valve technology and offer high flexibility, simplicity of installation, usage and maintenance.

Additionally they offer choice of vacuum source either pneumatic or electric, 3 standard dimensions 400, 600 and 800 mm in length and 120 mm in width with suction flow range from 705 to 2140 NI/mn. Special features include integrated filtration modules and vacuum monitoring.



VACUUM LIFTERS

VAC'easy COVAL range of suction pad lifters optimized for the sheet metal industry. It enables the lifting of sheet metals up to 800kg and is a very efficient, economic and reliable solution for numerous small scale workshops and machining industries.

VACUOPAL COVAL standard range of modular lifter available in either electric or pneumatic versions. Its high flexibility allows for the lifting of heavy loads in several positions: horizontally, vertically, pivoting at 90° or turning upside down at 180° with loads ranging from a minimum of 100kg upto several tons.

TUBE LIFTERS They are known for high security, precision and reliability. A single operator can handle with ease loads ranging from 20 to 300 kg such as small slabs, drums, carton boxes, sheet metal, etc.

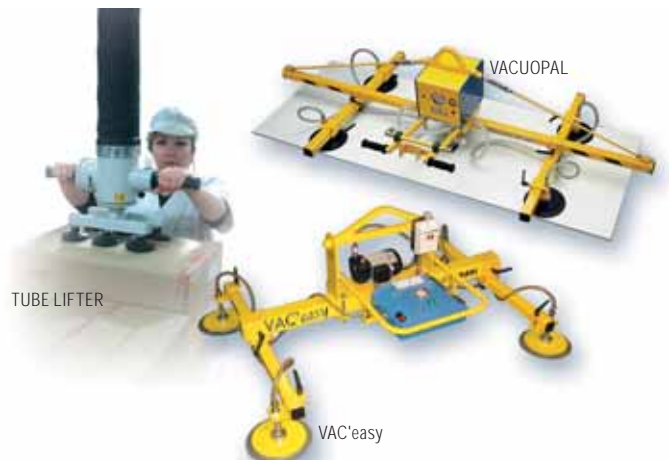

SYSTEM COMPONENTS

COVAL offers a complete range of individual lifting components adaptable to all types of needs.

They are easy to integrate, flexible and standard materials.

Product features:

Flat suction pads, Ø 120 to 600 mm - Spring systems - Pneumatic or electric central vacuum units equipped with all the necessary security options, reinforced with respect to stringent lifting regulations - Tubes, fittings, filters - Dry vane or lubricated vacuum pumps, etc.



To find more information about our vacuum systems range, please visit our website www.coval.com and download the related documentation. For further information contact your local COVAL correspondent.

www.coval.com



COVAL
vacuum managers

A TECHNOLOGICAL PARTNER WITH WORLDWIDE VISION

COVAL, *vacuum managers*, conceives, manufactures and commercializes worldwide components and systems for vacuum automation.

Every year, we keep developing our network of partners (subsidiaries, distributors and independent agents) as our objective is to assist our clients in their quest for local and international markets.

Our mission, is to go beyond the limits of a simple component supplier and assist our clients at each step of our interaction by :

- Organizing specialized training programs for our clients and partners.
- Proposing efficient, economic and reliable solutions
- Ensuring timely delivery and proper installation of our solutions.



COVAL INC.



COVAL AUTOMAÇÃO



COVAL S.A.S.



COVAL IBERICA



COVAL DEUTSCHLAND



COVAL ITALIA

Distributed by:

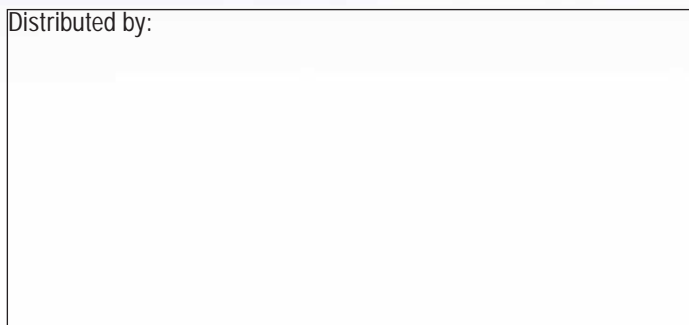

COVAL VACUUM TECHNOLOGY INC.
212-112 Powell Drive
Raleigh, NC 27606
Phone : (919) 233-4855
Fax : (919) 233-4854



www.coval-inc.com